



CATÁLOGO de productos

PRODUCT CATALOGUE
CATALOGUE DES PRODUITS
PRODUKTKATALOG

01
VERSIÓN





| passion
for tooling



















HOLA
HELLO
BONJOUR
HALLO

Somos una empresa joven pero con una trayectoria importante en el diseño, fabricación, control y distribución de herramienta de corte de metal duro.

Arralbe Tooling is a young company but with a long experience in design, manufacture, measuring and marketing of Solid Carbide Cutting Tools.

Arralbe tooling sl, c'est une jeune société d'une grande trajectoire, spécialisée dans le projet, réalisation et distribution d'outils en carbure monobloc.

Arralbe Tooling ist eine junge Firma. Wir haben jedoch eine große Erfahrung in der Entwicklung, Herstellung, Messung und Vertrieb von VHM Zerspanungswerkzeuge.

	Z1 FRESA FRENTE RECTO ALUMINIO Serie Normal PÁG 12 Z1 SQUARE END MILL FRAISE CYLINDRIQUE EN BOUT LANGLOCHFRÄFER Aluminium Normal Series
	Z1 FRESA FRENTE RECTO ALUMINIO Serie Larga PÁG 13 Z1 SQUARE END MILL FRAISE CYLINDRIQUE EN BOUT LANGLOCHFRÄFER Aluminium Long Series
	Z2 HELICE 45° Serie Normal PÁG 14 Z2 HELICE 45° SQUARE END MILL FRAISE CYLINDRIQUE EN BOUT LANGLOCHFRÄFER Aluminium Normal Series
	Z2 HELICE 45° Serie Larga PÁG 15 Z2 HELICE 45° SQUARE END MILL FRAISE CYLINDRIQUE EN BOUT LANGLOCHFRÄFER Aluminium Long Series
	Z2 HELICE 45° Serie Normal ZRN PÁG 16 Z2 HELICE 45° ZRN SQUARE END MILL FRAISE CYLINDRIQUE EN BOUT LANGLOCHFRÄFER Aluminium Normal Series
	Z2 HELICE 45° Serie Larga ZRN PÁG 17 Z2 HELICE 45° ZRN SQUARE END MILL FRAISE CYLINDRIQUE EN BOUT LANGLOCHFRÄFER Aluminium Long Series
	Z3 HELICE 45° Serie Normal PÁG 18 Z3 HELICE 45° SQUARE END MILL FRAISE CYLINDRIQUE EN BOUT LANGLOCHFRÄFER Aluminium Normal Series
	Z3 HELICE 45° Serie Larga PÁG 19 Z3 HELICE 45° SQUARE END MILL FRAISE CYLINDRIQUE EN BOUT LANGLOCHFRÄFER Aluminium Long Series
	Z3 HELICE 45° Serie Normal ZRN PÁG 20 Z3 HELICE 45° ZRN SQUARE END MILL FRAISE CYLINDRIQUE EN BOUT LANGLOCHFRÄFER Aluminium Normal Series
	Z3 HELICE 45° Serie Larga ZRN PÁG 21 Z3 HELICE 45° ZRN SQUARE END MILL FRAISE CYLINDRIQUE EN BOUT LANGLOCHFRÄFER Aluminium Long Series
	Z2 HELICE 40° Esférica Serie Normal PÁG 22 Z2 HELICE 40° BALL NOSE FRAISE CYLINDRIQUE À BOUT HÉMISPHERIQUE KUGELFRÄSER Aluminium Normal Series
	Z2 HELICE 40° Esférica Serie Larga PÁG 23 Z2 HELICE 40° BALL NOSE FRAISE CYLINDRIQUE À BOUT HÉMISPHERIQUE KUGELFRÄSER Aluminium Long Series
	Z2 HELICE 40° Esférica ZRN Serie Normal PÁG 24 Z2 HELICE 40° ZRN BALL NOSE FRAISE CYLINDRIQUE À BOUT HÉMISPHERIQUE KUGELFRÄSER Aluminium Normal Series
	Z2 HELICE 40° Esférica ZRN Serie Larga PÁG 25 Z2 HELICE 40° ZRN BALL NOSE FRAISE CYLINDRIQUE À BOUT HÉMISPHERIQUE KUGELFRÄSER Aluminium Long Series
	Z3 HELICE 45° Tórica Serie Larga PÁG 26 Z3 HELICE 45° CORNER RADIUS END MILL FRAISE TORIQUE À BOUT HÉMISPHERIQUE TORUSFRÄSER Aluminium Long Series
	Z3 HELICE 45° Tórica ZRN Serie Larga PÁG 27 Z3 HELICE 45° ZRN CORNER RADIUS END MILL FRAISE TORIQUE À BOUT HÉMISPHERIQUE TORUSFRÄSER Aluminium Long Series



Z2 FRESA FRENTE RECTO. SERIE NORMAL PÁG 30
Z2 SQUARE END MILL | FRAISE CYLINDRIQUE EN BOUT | LANGLOCHFRÄFER Normal Series



Z2 FRESA FRENTE RECTO. SERIE LARGA PÁG 32
Z2 SQUARE END MILL / FRAISE CYLINDRIQUE EN BOUT | LANGLOCHFRÄFER Long Series



Z2 FRESA FRENTE RECTO. SERIE EXTRA LARGA PÁG 33
Z2 SQUARE END MILL / FRAISE CYLINDRIQUE EN BOUT | LANGLOCHFRÄFER Extralong Series



Z3 FRESA FRENTE RECTO. SERIE NORMAL PÁG 34
Z3 SQUARE END MILL / FRAISE CYLINDRIQUE EN BOUT | LANGLOCHFRÄFER Normal Series



Z3 FRESA FRENTE RECTO. SERIE LARGA PÁG 36
Z3 SQUARE END MILL / FRAISE CYLINDRIQUE EN BOUT | LANGLOCHFRÄFER Long Series



Z4 FRESA FRENTE RECTO. SERIE EXTRA LARGA PÁG 37
Z4 SQUARE END MILL / FRAISE CYLINDRIQUE EN BOUT | LANGLOCHFRÄFER Extralong Series



Z4 FRESA FRENTE RECTO. SERIE NORMAL PÁG 38
Z4 SQUARE END MILL / FRAISE CYLINDRIQUE EN BOUT | LANGLOCHFRÄFER Normal Series



Z4 FRESA FRENTE RECTO. SERIE LARGA PÁG 40
Z4 SQUARE END MILL / FRAISE CYLINDRIQUE EN BOUT | LANGLOCHFRÄFER Long Series



Z6 FRESA MULTILABIO. SERIE NORMAL PÁG 42
Z6 MUTLIFLUTE END MILL | FRAISE CYLINDRIQUE MULTIDENTS | CHAFTFRÄSER MEHRSCHEIDEN Normal Series



Z6 FRESA MULTILABIO. SERIE LARGA Y EXTRALARGA PÁG 43
Z6 MUTLIFLUTE END MILL | FRAISE CYLINDRIQUE MULTIDENTS | CHAFTFRÄSER MEHRSCHEIDEN Long & Extralong Series



Z3 & Z4 FRESA SEMIDESBASTE FRENTE RECTO. SERIE NORMAL PÁG 44
Z3 & Z4 SEMI-ROUGHING END MILL | FRAISE CYLINDRIQUE EN BOUT | SEMI-FINITION SCHRUPPSCHLICHTFRÄFER Normal Series



Z4 FRESA SEMIDESBASTE FRENTE RECTO. SERIE LARGA PÁG 45
Z4 SEMI-ROUGHING END MILL | FRAISE CYLINDRIQUE EN BOUT | SEMI-FINITION SCHRUPPSCHLICHTFRÄFER Long Series



Z2 FRESA FRONTAL CUELLO REBAJADO. MANGO 6 PÁG 46
Z2 END MILL | FRAISE CYLINDRIQUE | LANGLOCHFRÄFER Shank 6



Z4 FRESA FRONTAL CUELLO REBAJADO. MANGO 6 PÁG 48
Z4 END MILL | FRAISE CYLINDRIQUE | LANGLOCHFRÄFER Shank 6



Z2 MICRO FRESA FRONTAL SIN CUELLO. MANGO 4 PÁG 50
Z2 MICRO END MILL | MICROFRAISE EN BOUT | MIKROLANGLOCHFRÄFER Shank 4



Z2 MICRO FRESA FRONTAL CUELLO REBAJADO. MANGO 4 PÁG 51
Z2 MICRO END MILL | MICROFRAISE EN BOUT | MIKROLANGLOCHFRÄFER Shank 4

	Z2 FRESAS ESFERICAS Serie Normal PÁG 54 Z2 BALL NOSE END MIL FRAISE CYLINDRIQUE HÉMISPHERIQUE KUGELFRÄSER Normal Series
	Z2 FRESAS ESFERICAS Serie Larga PÁG 56 Z2 BALL NOSE END MIL FRAISE CYLINDRIQUE HÉMISPHERIQUE KUGELFRÄSER Long Series
	Z2 FRESAS ESFERICAS Serie Extra Larga PÁG 57 Z2 BALL NOSE END MIL FRAISE CYLINDRIQUE HÉMISPHERIQUE KUGELFRÄSER Extralong Series
	Z4 FRESAS ESFERICAS Serie Normal PÁG 58 Z4 BALL NOSE END MIL FRAISE CYLINDRIQUE HÉMISPHERIQUE KUGELFRÄSER Normal Series
	Z4 FRESAS ESFERICAS Serie Larga PÁG 59 Z4 BALL NOSE END MIL FRAISE CYLINDRIQUE HÉMISPHERIQUE KUGELFRÄSER Long Series
	Z2 FRESAS ESFERICAS MANGO 4 PÁG 60 Z2 BALL NOSE END MIL Shank d4 FRAISE CYLINDRIQUE HÉMISPHERIQUE KUGELFRÄSER Shank 4
	Z2 FRESAS ESFERICAS MANGO 6 PÁG 62 Z2 BALL NOSE END MIL Shank d6 FRAISE CYLINDRIQUE HÉMISPHERIQUE KUGELFRÄSER Shank 6
	Z2 FRESAS ESFERICAS CÓNICAS PÁG 64 Z2 BALL NOSE END MIL FRAISE CYLINDRIQUE HÉMISPHERIQUE KUGELFRÄSER Conical Form
	Z2 FRESAS ESFERICAS CÓNICA 1° PÁG 66 Z2 BALL NOSE END MIL 1° FRAISE CYLINDRIQUE HÉMISPHERIQUE 1° KUGELFRÄSER 1° Conical Form
	Z2 FRESAS ESFERICAS CONICA 1,5° PÁG 68 Z2 BALL NOSE END MIL 1,5° FRAISE CYLINDRIQUE HÉMISPHERIQUE 1,5° KUGELFRÄSER 1,5° Conical Form
	Z2 ARRAL-TOP: FRESAS ESFERICAS CILÍNDRICAS PÁG 70 Z2 ARRAL-TOP: BALL NOSE END MILL FRAISE CYLINDRIQUE HÉMISPHERIQUE KUGELFRÄSER
	Z2 ARRAL-TOP: FRESAS ESFERICAS CÓNICAS 1° PÁG 71 Z2 ARRAL-TOP: BALL NOSE END MILL 1° FRAISE CYLINDRIQUE HÉMISPHERIQUE 1° KUGELFRÄSER 1°
	Z2 ARRAL-TOP: FRESAS ESFERICAS CÓNICAS 1,5° PÁG 72 Z2 ARRAL-TOP: BALL NOSE END MILL 1,5° FRAISE CYLINDRIQUE HÉMISPHERIQUE 1,5° KUGELFRÄSER 1,5°
	Z2 FRESAS ESFERICAS MATERIAL DURO Serie Normal PÁG 73 Z2 ARRAL-TOP: BALL NOSE END MILL Hard Cutting 70HRC FRAISE CYLINDRIQUE HÉMISPHERIQUE 70HRC KUGELFRÄSER 70HRC Normal Series
	Z2 FRESAS ESFERICAS MATERIAL DURO Serie Larga PÁG 74 Z2 ARRAL-TOP: BALL NOSE END MILL Hard Cutting 70HRC FRAISE CYLINDRIQUE HÉMISPHERIQUE 70HRC KUGELFRÄSER 70HRC Long Series
	Z2 MICRO FRESAS ESFERICAS PÁG 75 Z2 MICRO BALL NOSE END MILL MICROFRAISE CYLINDRIQUE HÉMISPHERIQUE MIKROKUGELFRÄSER
	Z2 MICRO FRESAS ESFERICAS Cuello rebajado PÁG 76 Z2 MICRO BALL NOSE END MILL MICROFRAISE CYLINDRIQUE HÉMISPHERIQUE MIKROKUGELFRÄSER Reduced neck

	Z2 FRESA TÓRICA Serie Normal	PÁG 78
	Z2 CORNER RADIUS END MIL FRAISE TORIQUE TORUSFRÄSER END MILL Normal Series	
	Z4 FRESA TÓRICA Serie Normal	PÁG 80
	Z4 CORNER RADIUS END MIL FRAISE TORIQUE TORUSFRÄSER END MILL Normal Series	
	Z2 FRESA TÓRICA Corte Normal	PÁG 82
	Z2 CORNER RADIUS END MIL FRAISE TORIQUE TORUSFRÄSER END MILL Normal Cuting	
	Z4 FRESA TÓRICA Corte Normal	PÁG 83
	Z4 CORNER RADIUS END MIL FRAISE TORIQUE TORUSFRÄSER END MILL Normal Cuting	
	Z2 FRESA TÓRICA Corte Largo	PÁG 84
	Z2 CORNER RADIUS END MIL FRAISE TORIQUE TORUSFRÄSER END MILL Long Cuting	
	Z4 FRESA TÓRICA Corte Largo	PÁG 86
	Z4 CORNER RADIUS END MIL FRAISE TORIQUE TORUSFRÄSER END MILL Long Cuting	
	Z2 FRESA TÓRICA Extralarga	PÁG 88
	Z2 CORNER RADIUS END MIL FRAISE TORIQUE TORUSFRÄSER END MILL Extralong Series	
	Z4 FRESA TÓRICA Extralarga	PÁG 89
	Z4 CORNER RADIUS END MIL FRAISE TORIQUE TORUSFRÄSER END MILL Extralong Series	
	Z2 FRESA TÓRICA CUELLO-MANGO D6	PÁG 90
	Z2 CORNER RADIUS END MIL SHANK D6 FRAISE TORIQUE SHANK D6 TORUSFRÄSER END MILL Shank 6	
	Z4 FRESA TÓRICA CUELLO-MANGO D6	PÁG 94
	Z4 CORNER RADIUS END MIL SHANK D6 FRAISE TORIQUE SHANK D6 TORUSFRÄSER END MILL Shank 6	
	Z2 FRESA TÓRICA CUELLO REBAJADO Serie Larga	PÁG 96
	Z2 CORNER RADIUS END MIL FRAISE TORIQUE TORUSFRÄSER END MILL Reduced Neck. Long Series	
	Z4 FRESA TÓRICA CUELLO REBAJADO Serie Larga	PÁG 99
	Z4 CORNER RADIUS END MIL FRAISE TORIQUE TORUSFRÄSER END MILL Reduced Neck. Long Series	
	Z4 FRESA TÓRICA CUELLO REBAJADO Serie Normal	PÁG 102
	Z4 CORNER RADIUS END MIL FRAISE TORIQUE TORUSFRÄSER END MILL Reduced Neck. Normal Series	
	Z2 FRESA TÓRICA CONICA A 1°	PÁG 104
	Z2 CORNER RADIUS END MIL 1° FRAISE TORIQUE 1° TORUSFRÄSER END MILL 1°	
	Z4 FRESA TÓRICA CONICA A 1°	PÁG 106
	Z4 CORNER RADIUS END MIL 1° FRAISE TORIQUE 1° TORUSFRÄSER END MILL 1°	
	Z2 FRESA TÓRICA CONICA A 1,5°	PÁG 108
	Z2 CORNER RADIUS END MIL 1,5° FRAISE TORIQUE 1,5° TORUSFRÄSER END MILL 1,5°	
	Z4 FRESA TÓRICA CONICA A 1,5°	PÁG 110
	Z4 CORNER RADIUS END MIL 1,5° FRAISE TORIQUE 1,5° TORUSFRÄSER END MILL 1,5°	



Z3 HYPERLINK: FRESA HELICE VARIABLE 35°/38° Económica..... PÁG 112
Z3 HYPERLINK. UNEQUAL HELIX ANGLES 35°-38° | HÉLICE DIFFÉRENTE 35°-38° | UNGLEICHER DRALLWINKEL 35°-38° Eco.



Z4 HYPERLINK: FRESA HELICE VARIABLE 35°/38° Económica..... PÁG 113
Z4 HYPERLINK. UNEQUAL HELIX ANGLES 35°-38° | HÉLICE DIFFÉRENTE 35°-38° | UNGLEICHER DRALLWINKEL 35°-38° Eco.



Z4 HYPERLINK: FRESA HELICE VARIABLE 35°/38° WELDOM Económica..... PÁG 114
Z4 HYPERLINK. UNEQUAL HELIX ANGLES 35°-38° | HÉLICE DIFFÉRENTE 35°-38° | UNGLEICHER DRALLWINKEL 35°-38° Eco. Weldom



Z4 HYPERLINK: FRESA H.V. 35°/38° Medidas especiales. Económica..... PÁG 115
Z4 HYPERLINK. UNEQUAL HELIX ANGLES 35°-38° | HÉLICE DIFFÉRENTE 35°-38° | UNGLEICHER DRALLWINKEL 35°-38° Special Sizes. Eco.



Z4 HYPERLINK: FRESA H.V. 35°/38° Cuello Rebajado. Económica..... PÁG 116
Z4 HYPERLINK. UNEQUAL HELIX ANGLES 35°-38° | HÉLICE DIFFÉRENTE 35°-38° | UNGLEICHER DRALLWINKEL 35°-38° R. Neck. Eco.



Z4 HYPERLINK: F. H. V. 35°/38° Cuello Rebajado WELDOM. Económica..... PÁG 117
Z4 HYPERLINK. UNEQUAL HELIX ANGLES 35°-38° | HÉLICE DIFFÉRENTE 35°-38° | UNGLEICHER DRALLWINKEL 35°-38° R. Neck. Weldom



Z4 HYPERLINK PLUS: FRESA HELICE VARIABLE 35°/38° Cuello Rebajado PÁG 118
Z4 HYPERLINK PLUS. UNEQUAL HELIX ANGLES 35°-38° | HÉLICE DIFFÉRENTE 35°-38° | UNGLEICHER DRALLWINKEL 35°-38° R. Neck. Premium



Z4 HYPERLINK PLUS: FRESA H. VARIABLE 35°/38° C. Rebajado WELDOM PÁG 119
Z4 HYPERLINK PLUS. UNEQUAL HELIX ANGLES 35°-38° | HÉLICE DIFFÉRENTE 35°-38° | UNGLEICHER DRALLWINKEL 35°-38° R. Neck. Weldom



Z4 HYRUX: FRESA HELICE VARIABLE 43°/45° Alto Rendimiento PÁG 120
Z4 HYRUX. UNEQUAL HELIX ANGLES 43°-45° | HÉLICE DIFFÉRENTE 43°-45° | UNGLEICHER DRALLWINKEL 43°-45° Premium



Z4 HYRUX: FRESA H.V. 43°/45° WELDOM Alto Rendimiento PÁG 121
Z4 HYRUX. UNEQUAL HELIX ANGLES 43°-45° | HÉLICE DIFFÉRENTE 43°-45° | UNGLEICHER DRALLWINKEL 43°-45° Weldom. Premium



Z4 HYRUX: FRESA H.V. 43°/45° Cuello Rebajado. Alto Rendimiento PÁG 122
Z4 HYRUX. UNEQUAL HELIX ANGLES 43°-45° | HÉLICE DIFFÉRENTE 43°-45° | UNGLEICHER DRALLWINKEL 43°-45° R. Neck. Premium



Z4 HYRUX: F.H.V. 43°/45° Cuello Rebajado WELDOM Alto Rendimiento..... PÁG 123
Z4 HYRUX. UNEQUAL HELIX ANGLES 43°-45° | HÉLICE DIFFÉRENTE 43°-45° | UNGLEICHER DRALLWINKEL 43°-45° R. Neck. Weldom



Z4 HYRUX TITANIO: FRESA HELICE VARIABLE 43°/45° PÁG 124
Z4 HYRUX TITANIUM. UNEQUAL HELIX ANGLES 43°-45° | HÉLICE DIFFÉRENTE 43°-45° | UNGLEICHER DRALLWINKEL 43°-45°



Z4 HYRUX TITANIO: FRESA HELICE VARIABLE 43°/45° WELDOM PÁG 125
Z4 HYRUX TITANIUM. UNEQUAL HELIX ANGLES 43°-45° | HÉLICE DIFFÉRENTE 43°-45° | UNGLEICHER DRALLWINKEL 43°-45° Weldom



Z4 HYRUX TITANIO: FRESA H. V. 43°/45° Cuello Rebajado..... PÁG 126
Z4 HYRUX TITANIUM. UNEQUAL HELIX ANGLES 43°-45° | HÉLICE DIFFÉRENTE 43°-45° | UNGLEICHER DRALLWINKEL 43°-45° R. Neck



Z4 HYRUX TITANIO: FRESA H. V. 43°/45° Cuello Rebajado WELDOM PÁG 127
Z4 HYRUX TITANIUM. UNEQUAL HELIX ANGLES 43°-45° | HÉLICE DIFFÉRENTE 43°-45° | UNGLEICHER DRALLWINKEL 43°-45° Weldom



Z5 HELIX: FRESA HELICE VARIABLE 43°/45° Chaflán <55HRC PÁG 128
Z5 HELIX. UNEQUAL HELIX ANGLES 43°-45° | HÉLICE DIFFÉRENTE 43°-45° | UNGLEICHER DRALLWINKEL 43°-45° <55HRC



Z5 HELIX: FRESA HELICE VARIABLE 43°/45° Chaflán <65HRC PÁG 130
Z5 HELIX. UNEQUAL HELIX ANGLES 43°-45° | HÉLICE DIFFÉRENTE 43°-45° | UNGLEICHER DRALLWINKEL 43°-45° <65HRC



Z5 HELIX: FRESA H.V. 43°/45° Chaflán <55HRC Refrigeración Central PÁG 132
Z5 HELIX. UNEQUAL HELIX ANGLES 43°-45° | HÉLICE DIFFÉRENTE 43°-45° | UNGLEICHER DRALLWINKEL 43°-45° <55HRC Central Coolant



Z5 HELIX: FRESA HELICE VARIABLE 43°/45° Radio <55HRC PÁG 134
Z5 HELYX. UNEQUAL HELIX ANGLES | HÉLICE DIFFÉRENTE | UNGLEICHER DRALLWINKEL 43°-45° <55HCR



Z5 HELIX: FRESA HELICE VARIABLE 43°/45° Radio <65HRC PÁG 136
Z5 HELYX. UNEQUAL HELIX ANGLES | HÉLICE DIFFÉRENTE | UNGLEICHER DRALLWINKEL 43°-45° <65HCR



Z5 HELIX: FRESA H.V. 43°/45° Radio <55HRC Refrigeración central PÁG 138
Z5 HELYX. UNEQUAL HELIX ANGLES | HÉLICE DIFFÉRENTE | UNGLEICHER DRALLWINKEL 43°-45° <55HCR Coolant



Z4 HYPERBALL: FRESA HÉLICE VARIABLE ESFÉRICA..... PÁG 140
Z4 HYPERBALL. BALL NOSE END MILL | FRAISE CYLINDRIQUE HÉMISPHERIQUE | UNGLEICHER DRALLWINKEL



Z4 HYPERBALL: FRESA HÉLICE VARIABLE ESFÉRICA. Cónica 1,5° PÁG 141
Z4 HYPERBALL. BALL NOSE END MILL 1.5° | FRAISE CYLINDRIQUE HÉMISPHERIQUE 1.5° | UNGLEICHER DRALLWINKEL 1.5°



Z4 FRESA TURBO ALTO AVANCE Serie Normal PÁG 142
Z4 TURBO HIGH FEED END MILL | TURBO FRAISE CYLINDRIQUE DE HAUTE AVANCE | TURBO HOCHVORSCHUBFRÄSER N. Series



Z4 FRESA TURBO ALTO AVANCE Serie Larga PÁG 143
Z4 TURBO HIGH FEED END MILL | TURBO FRAISE CYLINDRIQUE DE HAUTE AVANCE | TURBO HOCHVORSCHUBFRÄSER L. Series



Z4-Z6 FRESA PARA ACHAFLANAR 60° PÁG 144
Z4-Z6 COUNTERSINKER 60° | CHAMFREIN 60° | KEGELSENKER 60°



Z4-Z6 FRESA PARA ACHAFLANAR 90° PÁG 145
Z4-Z6 COUNTERSINKER 90° | CHAMFREIN 90° | KEGELSENKER 90°



Z5 TROCOIDAL: FRESA DE ALTO RENDIMIENTO PÁG 146
Z5 TROCHOIDAL. HIGH PERFORMANCE END MILL | FRAISE DE HAUTE PERFORMANCE
 UNGLEICHER DRALLWINKEL HOCHLEISTUNGSBEARBEITUNG

6

BROCAS de metal duro

SOLID CARBIDE DRILL | FORET EN CARBURE MONOBLOC | VOLLHARTMETALLBOHRER



3XD BROCA METAL DURO DIN6537K PÁG 148
3XD SOLID CARBIDE DRILL | FORET EN CARBURE MONOBLOC | VOLLHARTMETALLBOHRER DIN6537K



5XD BROCA METAL DURO DIN6537L Con refrigeración PÁG 152
5XD SOLID CARBIDE DRILL | FORET EN CARBURE MONOBLOC | VOLLHARTMETALLBOHRER DIN6537L Internal Coolant



5XD BROCA METAL DURO DIN6537L PÁG 156
5XD SOLID CARBIDE DRILL | FORET EN CARBURE MONOBLOC | VOLLHARTMETALLBOHRER DIN6537L



8XD BROCA METAL DURO DIN6537L Con refrigeración PÁG 160
8XD SOLID CARBIDE DRILL | FORET EN CARBURE MONOBLOC | VOLLHARTMETALLBOHRER DIN6537L Internal Coolant

7

ESCARIADORES

REAMERS | ALÉSOIRS | REIBAHLN



ESCARIADOR METAL DURO Sin recubrimiento PÁG 166
ARRALBE HELIX 10° | H7

PAUTAS de corte PÁG 170
 CUTTING PARAMETERS | PARAMÉTRÉS DE COUPE | SCHNITTDATEN





01

FRESAS para aluminio

END MILL FOR ALUMINIUM
FRAISE POUR ALUMINIUM
FRÄFER FÜR ALUMINIUM

I Z1 FRESA FRENTA RECTO ALUMINIO Serie Normal SIN RECUBRIMIENTO

EN Z1 SQUARE END MILL ALUMINIUM | UNCOATED | Normal Series

FR Z1 FRAISE CYLINDRIQUE EN BOUT ALUMINIUM | NO REVÊTEMENT | Normale

DE Z1 LANGLOCHFRÄFER ALUMINIUM | OHNE BESCHICHTUNG | Normale

ES Aluminio, cobre, latón, bronce y termoplásticos.

EN Aluminium, copper, brass, bronze and thermoplastics.

FR Aluminium, cuivre, laiton, bronze et thermoplastiques.

DE Aluminium, kupfer, messing, bronce und kunststoffe.

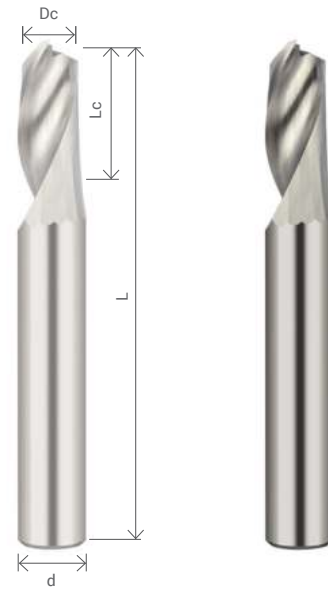
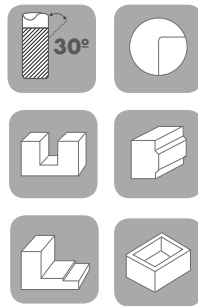

SERIE NORMAL

Ref.	Dimensiones (mm)				Precio €
1 Flute (Z1)	Dc	d	Lc	L	
A-SEM1030	3	3	8	38	
A-SEM1040	4	4	11	50	
A-SEM1050	5	5	13	50	
A-SEM1060	6	6	16	50	
A-SEM1080	8	8	19	60	
A-SEM1100	10	10	22	75	
A-SEM1120	12	12	26	75	

Z1 FRESA FRENTE RECTO ALUMINIO Serie Larga SIN RECUBRIMIENTO

EN Z1 SQUARE END MILL ALUMINIUM | UNCOATED | Long Series

FR Z1 FRAISE CYLINDRIQUE EN BOUT ALUMINIUM | NO REVÊTEMENT | Longue

DE Z1 LANGLOCHFRÄSER ALUMINIUM | OHNE BESCHICHTUNG | Lange

ES Aluminio, cobre, latón, bronce y termoplásticos.

EN Aluminium, copper, brass, bronze and thermoplastics.

FR Aluminium, cuivre, laiton, bronze et thermoplastiques.

DE Aluminium, kupfer, messing, bronze und kunststoffe.

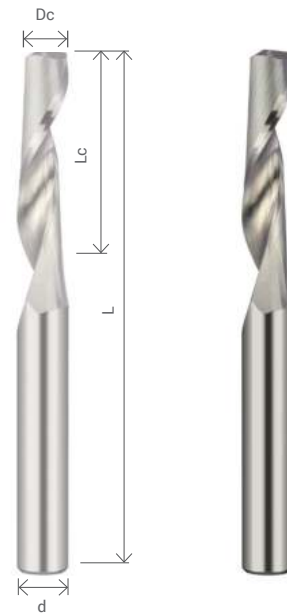
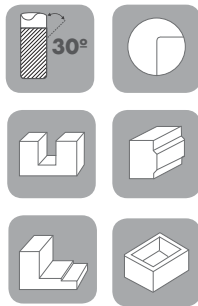

SERIE LARGA

					Precio €
1 Flute (Z1)	Dc	d	Lc	L	
A-SEM1060L	6	6	25	80	
A-SEM1080L	8	8	35	90	
A-SEM1100L	10	10	45	100	
A-SEM1120L	12	12	50	100	

I Z2 HELICE 45° Serie Normal

FRESA FRENTE RECTO ALUMINIO

EN Z2 HELICE 45° SQUARE END MILL ALUMINIUM | UNCOATED | Normal Series,
FR Z2 HELICE 45° FRAISE CYLINDRIQUE EN BOUT ALUMINIUM | NO REVÊTEMENT | Normale
DE Z2 HELICE 45° LANGLOCHFRÄSER ALUMINIUM | OHNE BESCHICHTUNG | Normale

- ES** Aluminio, cobre, latón, bronce y termoplásticos.
- EN** Aluminium, copper, brass, bronze and thermoplastics.
- FR** Aluminium, cuivre, laiton, bronze et thermoplastiques.
- DE** Aluminium, kupfer, messing, bronce und kunststoffe.

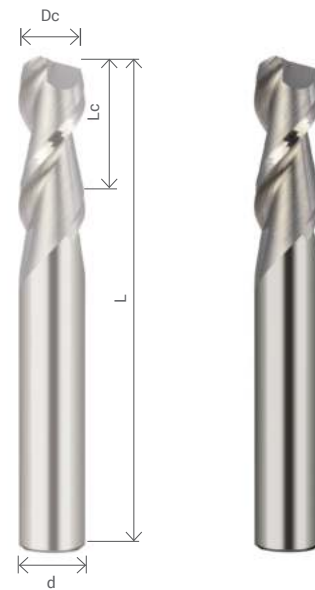
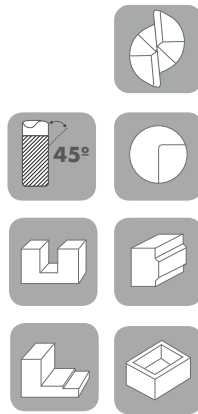

SERIE NORMAL

Ref.	Dimensiones (mm)				Precio €
	Dc	d	Lc	L	
2 Flutes (Z2)					
A-SEM2030	3	6	8	50	
A-SEM2040	4	6	11	50	
A-SEM2050	5	6	13	50	
A-SEM2060	6	6	16	50	
A-SEM2080	8	8	19	60	
A-SEM2100	10	10	25	72	
A-SEM2120	12	12	30	75	
A-SEM2140	14	14	35	84	
A-SEM2160	16	16	40	92	
A-SEM2200	20	20	45	100	

Z2 HELICE 45° Serie Larga

FRESA FRENTE RECTO ALUMINIO

EN Z2 HELICE 45° SQUARE END MILL ALUMINIUM | UNCOATED | Long Series

FR Z2 HELICE 45° FRAISE CYLINDRIQUE EN BOUT ALUMINIUM | NO REVÊTEMENT | Longue

DE Z2 HELICE 45° LANGLOCHFRÄSER ALUMINIUM | OHNE BESCHICHTUNG | Lange

ES Aluminio, cobre, latón, bronce y termoplásticos.

EN Aluminium, copper, brass, bronze and thermoplastics.

FR Aluminium, cuivre, laiton, bronze et thermoplastiques.

DE Aluminium, kupfer, messing, bronce und kunststoffe.

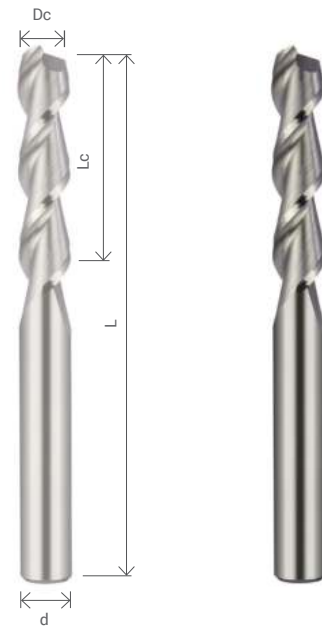
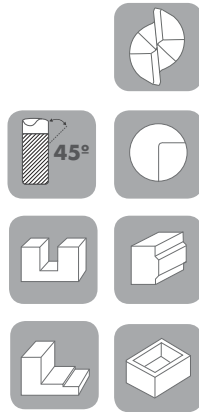

SERIE LARGA

Ref.	Dimensiones (mm)				Precio €
	Dc	d	Lc	L	
2 Flutes (Z2)					
A-SEM2060L	6	6	25	80	
A-SEM2080L	8	8	35	90	
A-SEM2100L	10	10	45	100	
A-SEM2120L	12	12	50	100	
A-SEM2140L	14	14	65	150	
A-SEM2160L	16	16	75	150	
A-SEM2200L	20	20	80	150	

Z2 HELICE 45° Serie Normal ZRN

FRESA FRENTE RECTO ALUMINIO / RECUBRIMIENTO ZRN

EN Z2 HELICE 45° SQUARE END MILL ALUMINIUM | ZRN COATED | Normal Series

FR Z2 HELICE 45° FRAISE CYLINDRIQUE EN BOUT ALUMINIUM | REVÊTEMENT ZRN | Normale

DE Z2 HELICE 45° LANGLOCHFRÄFER ALUMINIUM | BESCHICHTUNG ZRN | Normale

ES Aluminio, cobre, latón, bronce y termoplásticos.

EN Aluminium, copper, brass, bronze and thermoplastics.

FR Aluminium, cuivre, laiton, bronze et thermoplastiques.

DE Aluminium, kupfer, messing, bronce und kunststoffe.

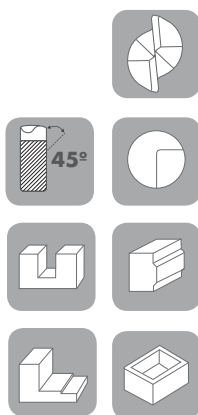

ZRN

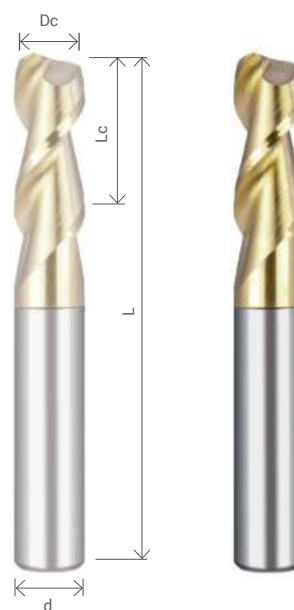

SERIE NORMAL

Ref.	Dimensiones (mm)				Precio €
	Dc	d	Lc	L	
2 Flutes (Z2)					
A-SEM2030Z	3	6	8	50	
A-SEM2040Z	4	6	11	50	
A-SEM2050Z	5	6	13	50	
A-SEM2060Z	6	6	16	50	
A-SEM2080Z	8	8	19	60	
A-SEM2100Z	10	10	25	72	
A-SEM2120Z	12	12	30	75	
A-SEM2140Z	14	14	35	84	
A-SEM2160Z	16	16	40	92	
A-SEM2200Z	20	20	45	100	

Z2 HELICE 45° Serie Larga ZRN

FRESA FRENTA RECTO ALUMINIO / RECUBRIMIENTO ZRN

EN Z2 HELICE 45° SQUARE END MILL ALUMINIUM | ZRN COATED | Long Series

FR Z2 HELICE 45° FRAISE CYLINDRIQUE EN BOUT ALUMINIUM | REVÊTEMENT ZRN | Longue

DE Z2 HELICE 45° LANGLOCHFRÄFER ALUMINIUM | BESCHICHTUNG ZRN | Lange

- ES Aluminio, cobre, latón, bronce y termoplásticos.
- EN Aluminium, copper, brass, bronze and thermoplastics.
- FR Aluminium, cuivre, laiton, bronze et thermoplastiques.
- DE Aluminium, kupfer, messing, bronce und kunststoffe.

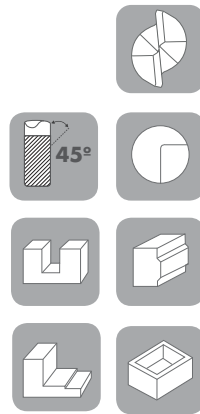

ZRN

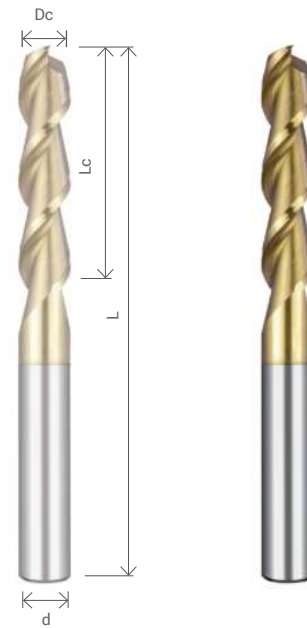

SERIE LARGA

Ref.	Dimensiones (mm)				Precio €
	Dc	d	Lc	L	
2 Flutes (Z2)					
A-SEM2060LZ	6	6	25	80	
A-SEM2080LZ	8	8	35	90	
A-SEM2100LZ	10	10	45	100	
A-SEM2120LZ	12	12	50	100	
A-SEM2140LZ	14	14	65	150	
A-SEM2160LZ	16	16	75	150	
A-SEM2200LZ	20	20	80	150	

Z3 HELICE 45° Serie Normal

FRESA FRENTE RECTO ALUMINIO / SIN RECUBRIMIENTO

EN Z3 HELICE 45° SQUARE END MILL ALUMINIUM | UNCOATED | Normal Series

FR Z3 HELICE 45° FRAISE CYLINDRIQUE EN BOUT ALUMINIUM | NO REVÊTEMENT | Normale

DE Z3 HELICE 45° LANGLOCHFRÄFER ALUMINIUM | OHNE BESCHICHTUNG | Normale

ES Aluminio, cobre, latón, bronce y termoplásticos.

EN Aluminium, copper, brass, bronze and thermoplastics.

FR Aluminium, cuivre, laiton, bronze et thermoplastiques.

DE Aluminium, kupfer, messing, bronze und kunststoffe.

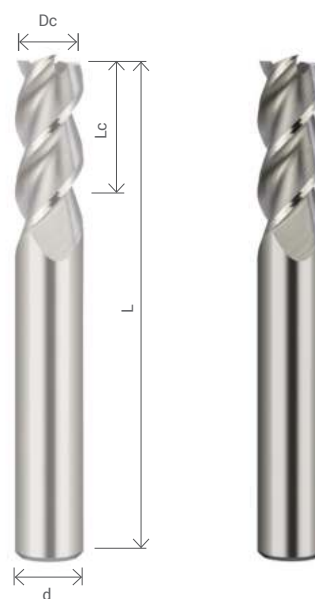
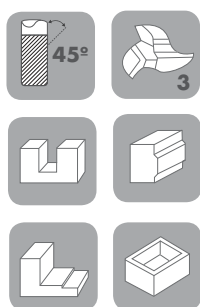

SERIE NORMAL

Ref.	Dimensiones (mm)				Precio €
	Dc	d	Lc	L	
3 Flutes (Z3)					
A-SEM3030	3	6	8	50	
A-SEM3040	4	6	11	50	
A-SEM3050	5	6	13	50	
A-SEM3060	6	6	16	50	
A-SEM3080	8	8	19	60	
A-SEM3100	10	10	25	72	
A-SEM3120	12	12	30	75	
A-SEM3140	14	14	35	84	
A-SEM3160	16	16	40	92	
A-SEM3200	20	20	45	100	

Z3 HELICE 45° Serie Larga

FRESA FRENTA RECTO ALUMINIO / SIN RECUBRIMIENTO

EN Z3 HELICE 45° SQUARE END MILL ALUMINIUM | UNCOATED | Long Series

FR Z3 HELICE 45° FRAISE CYLINDRIQUE EN BOUT ALUMINIUM | NO REVÊTEMENT | Longue

DE Z3 HELICE 45° LANGLOCHFRÄFER ALUMINIUM | OHNE BESCHICHTUNG | Lange

ES Aluminio, cobre, latón, bronce y termoplásticos.

EN Aluminium, copper, brass, bronze and thermoplastics.

FR Aluminium, cuivre, laiton, bronze et thermoplastiques.

DE Aluminium, kupfer, messing, bronze und kunststoffe.

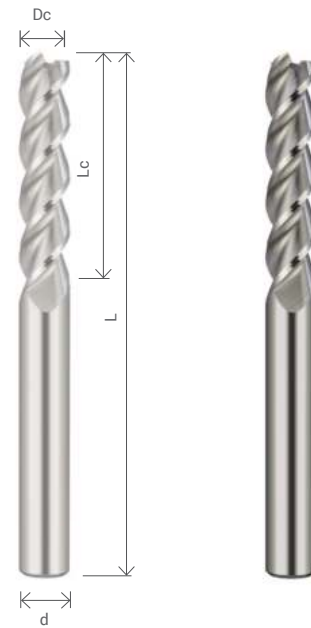
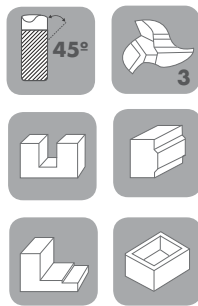

SERIE LARGA

Ref.	Dimensiones (mm)				Precio €
	Dc	d	Lc	L	
3 Flutes (Z3)					
A-SEM3060L	6	6	25	80	
A-SEM3080L	8	8	35	90	
A-SEM3100L	10	10	45	100	
A-SEM3120L	12	12	50	100	
A-SEM3140L	14	14	65	150	
A-SEM3160L	16	16	75	150	
A-SEM3200L	20	20	80	150	

I Z3 HELICE 45° Serie Normal ZRN

FRESA FRENTE RECTO ALUMINIO / RECUBRIMIENTO ZRN

EN Z3 HELICE 45° SQUARE END MILL ALUMINIUM | ZRN COATED | Normal Series

FR Z3 HELICE 45° FRAISE CYLINDRIQUE EN BOUT ALUMINIUM | REVÊTEMENT ZRN | Normale

DE Z3 HELICE 45° LANGLOCHFRÄFER ALUMINIUM | BESCHICHTUNG ZRN | Normale

ES Aluminio, cobre, latón, bronce y termoplásticos.

EN Aluminium, copper, brass, bronze and thermoplastics.

FR Aluminium, cuivre, laiton, bronze et thermoplastiques.

DE Aluminium, kupfer, messing, bronce und kunststoffe.

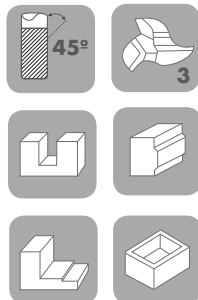

ZRN

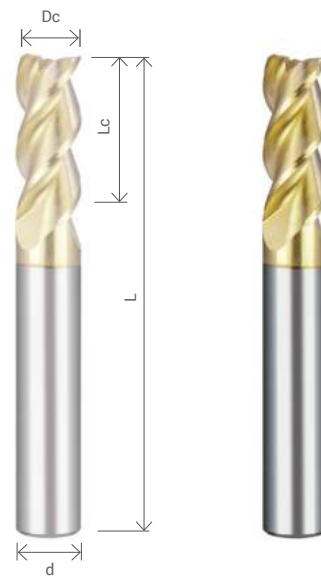

SERIE NORMAL

Ref.	Dimensiones (mm)				Precio €
	Dc	d	Lc	L	
3 Flutes (Z3)					
A-SEM3030Z	3	6	8	50	
A-SEM3040Z	4	6	11	50	
A-SEM3050Z	5	6	13	50	
A-SEM3060Z	6	6	16	50	
A-SEM3080Z	8	8	19	60	
A-SEM3100Z	10	10	25	72	
A-SEM3120Z	12	12	30	75	
A-SEM3140Z	14	14	35	84	
A-SEM3160Z	16	16	40	92	
A-SEM3200Z	20	20	45	100	

Z3 HELICE 45° Serie Larga ZRN

FRESA FRENTA RECTO ALUMINIO / RECUBRIMIENTO ZRN

EN Z3 HELICE 45° SQUARE END MILL ALUMINIUM | ZRN COATED | Long Series

FR Z3 HELICE 45° FRAISE CYLINDRIQUE EN BOUT ALUMINIUM | REVÊTEMENT ZRN | Longue

DE Z3 HELICE 45° LANGLOCHFRÄFER ALUMINIUM | BESCHICHTUNG ZRN | Lange

ES Aluminio, cobre, latón, bronce y termoplásticos.

EN Aluminium, copper, brass, bronze and thermoplastics.

FR Aluminium, cuivre, laiton, bronze et thermoplastiques.

DE Aluminium, kupfer, messing, bronze und kunststoffe.

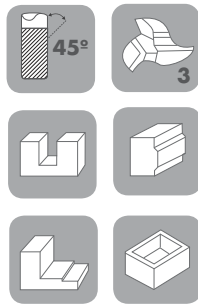

ZRN

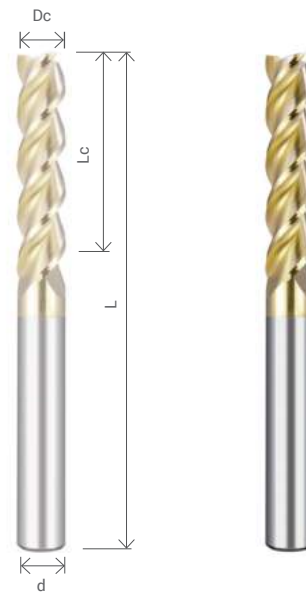

SERIE LARGA

Ref.	Dimensiones (mm)				Precio €
3 Flutes (Z3)	Dc	d	Lc	L	
A-SEM3060LZ	6	6	25	80	
A-SEM3080LZ	8	8	35	90	
A-SEM3100LZ	10	10	45	100	
A-SEM3120LZ	12	12	50	100	
A-SEM3140LZ	14	14	65	150	
A-SEM3160LZ	16	16	75	150	
A-SEM3200LZ	20	20	80	150	

I Z2 HELICE 40° Serie Normal

FRESA ESFERICA ALUMINIO / SIN RECUBRIMIENTO

EN Z2 BALL NOSE ALUMINIUM END MILL | UNCOATED | Normal Series

FR Z2 FRAISE CYLINDRIQUE À BOUT HÉMISPHERIQUE ALUMINIUM | NO REVÊTEMENT | Normale

DE Z2 KUGELFRÄSER ALUMINIUM | OHNE BESCHICHTUNG | Normale

ES Aluminio, cobre, latón, bronce y termoplásticos.

EN Aluminium, copper, brass, bronze and thermoplastics.

FR Aluminium, cuivre, laiton, bronze et thermoplastiques.

DE Aluminium, kupfer, messing, bronze und kunststoffe.

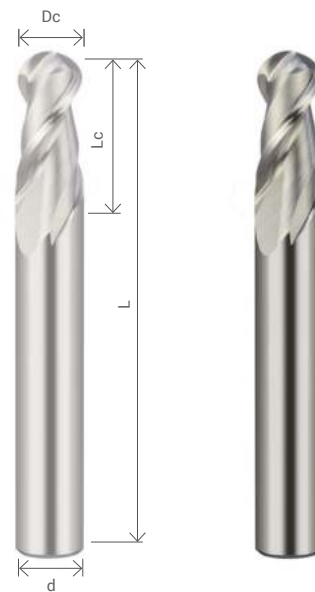

SERIE NORMAL

Ref.	Dimensiones (mm)				Precio €
	Dc	d	Lc	L	
2 Flutes (Z2)					
A-SBM2030	3	6	6	50	
A-SBM2040	4	6	8	50	
A-SBM2050	5	6	10	50	
A-SBM2060	6	6	12	50	
A-SBM2080	8	8	15	60	
A-SBM2100	10	10	20	72	
A-SBM2120	12	12	24	75	
A-SBM2140	14	14	26	83	
A-SBM2160	16	16	30	92	
A-SBM2200	20	20	40	100	

I Z2 HELICE 40° Serie Larga

FRESA ESFERICA ALUMINIO / SIN RECUBRIMIENTO

EN Z2 BALL NOSE ALUMINIUM END MILL | UNCOATED | Long Series

FR Z2 FRAISE CYLINDRIQUE À BOUT HÉMISPHERIQUE ALUMINIUM | NO REVÊTEMENT | Longue

DE Z2 KUGELFRÄSER ALUMINIUM | OHNE BESCHICHTUNG | Lange

ES Aluminio, cobre, latón, bronce y termoplásticos.

EN Aluminium, copper, brass, bronze and thermoplastics.

FR Aluminium, cuivre, laiton, bronze et thermoplastiques.

DE Aluminium, kupfer, messing, bronze und kunststoffe.



SERIE LARGA

Ref.	Dimensiones (mm)						Precio €
	Dc	d	U/C	U	Lc	L	
A-SBM2060L	6	6	5,5	35	12	80	
A-SBM2080L	8	8	7,5	35	15	90	
A-SBM2100L	10	10	9,5	45	20	100	
A-SBM2120L	12	12	11,5	50	24	100	
A-SBM2160L	16	16	15,5	92	30	150	
A-SBM2200L	20	20	19,5	92	40	150	

I Z2 HELICE 40° ZRN Serie Normal

FRESA ESFERICA ALUMINIO / RECUBRIMIENTO ZRN

EN Z2 HELICE 40° BALL NOSE ALUMINIUM END MILL | ZRN COATED | Normal Series.

FR Z2 HELICE 40° FRAISE CYLINDRIQUE À BOUT HÉMISPHERIQUE ALUMINIUM | REVÊTEMENT ZRN | Normale

DE Z2 HELICE 40° KUGELFRÄSER ALUMINIUM | BESCHICHTUNG ZRN | Normale

ES Aluminio, cobre, latón, bronce y termoplásticos.

EN Aluminium, copper, brass, bronze and thermoplastics.

FR Aluminium, cuivre, laiton, bronze et thermoplastiques.

DE Aluminium, kupfer, messing, bronce und kunststoffe.



ZRN

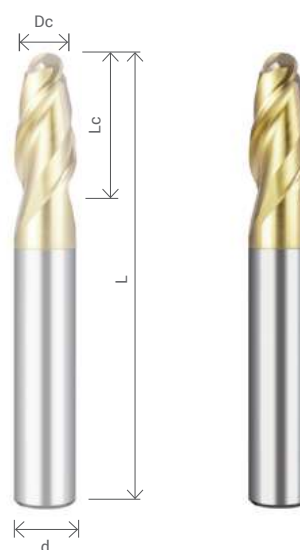

SERIE NORMAL

Ref.	Dimensiones (mm)				Precio €
	Dc	d	Lc	L	
2 Flutes (Z2)					
A-SBM2030Z	3	6	6	50	
A-SBM2040Z	4	6	8	50	
A-SBM2050Z	5	6	10	50	
A-SBM2060Z	6	6	12	50	
A-SBM2080Z	8	8	15	60	
A-SBM2100Z	10	10	20	72	
A-SBM2120Z	12	12	24	75	
A-SBM2140Z	14	14	26	83	
A-SBM2160Z	16	16	30	92	
A-SBM2200Z	20	20	40	100	

Z2 HELICE 40° ZRN Serie Larga

FRESA ESFERICA ALUMINIO / RECUBRIMIENTO ZRN

EN Z2 HELICE 40° BALL NOSE ALUMINIUM END MILL | ZRN COATED | Long Series

FR Z2 HELICE 40° FRAISE CYLINDRIQUE À BOUT HÉMISPHERIQUE ALUMINIUM | REVÊTEMENT ZRN | Longue

DE Z2 HELICE 40° KUGELFRÄSER ALUMINIUM | BESCHICHTUNG ZRN | Lange

ES Aluminio, cobre, latón, bronce y termoplásticos.

EN Aluminium, copper, brass, bronze and thermoplastics.

FR Aluminium, cuivre, laiton, bronze et thermoplastiques.

DE Aluminium, kupfer, messing, bronce und kunststoffe.



ZRN

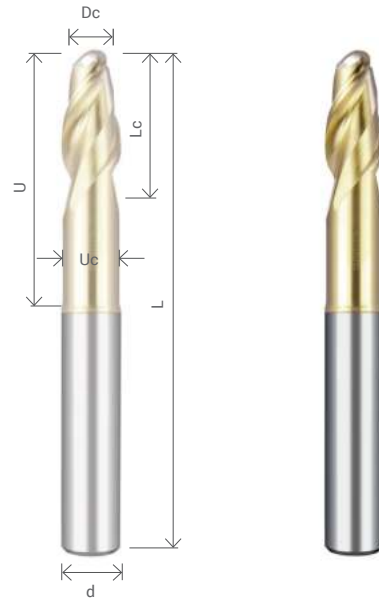

SERIE LARGA

Ref.	Dimensiones (mm)						Precio €
	2 Flutes (Z2)	Dc	d	U/C	U	Lc	
A-SBM2060LZ		6	6	5,5	35	12	80
A-SBM2080LZ		8	8	7,5	35	15	90
A-SBM2100LZ		10	10	9,5	45	20	100
A-SBM2120LZ		12	12	11,5	50	24	100
A-SBM2160LZ		16	16	15,5	92	30	150
A-SBM2200LZ		20	20	19,5	92	40	150

Z3 HELICE 45° Serie Larga

FRESA TÓRICA ALUMINIO / SIN RECUBRIMIENTO

EN Z3 HELICE 45° CORNER RADIUS ALUMINIUM END MILL | UNCOATED | Long Series

FR Z3 HELICE 45° FRAISE TORIQUE À BOUT HÉMISPHERIQUE ALUMINIUM | NO REVÊTEMENT | Longue

DE Z3 HELICE 45° TORUSFRÄSER ALUMINIUM | OHNE BESCHICHTUNG | Lange

ES Aluminio, cobre, latón, bronce y termoplásticos.

EN Aluminium, copper, brass, bronze and thermoplastics.

FR Aluminium, cuivre, laiton, bronze et thermoplastiques.

DE Aluminium, kupfer, messing, bronze und kunststoffe.

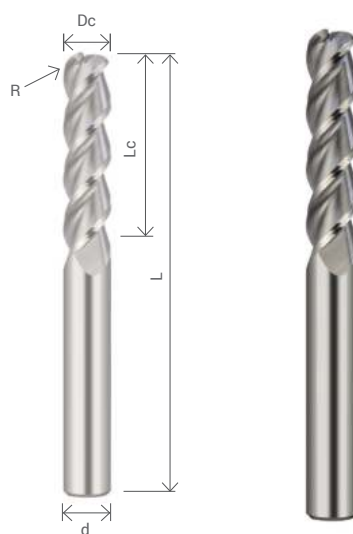
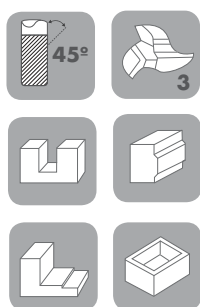

SERIE LARGA SIN RECUBRIMIENTO

Ref.	Dimensiones (mm)					Precio €
	Dc	d	R	Lc	L	
3 Flutes (Z3)						
A-SEM3060L-R0,5	6	6	0,5	25	80	
A-SEM3060L-R1	6	6	1	25	80	
A-SEM3080L-R0,5	8	8	0,5	35	90	
A-SEM3080L-R1	8	8	1	35	90	
A-SEM3100L-R0,5	10	10	0,5	45	100	
A-SEM3100L-R1	10	10	1	45	100	
A-SEM3100L-R2	10	10	2	45	100	
A-SEM3100L-R3	10	10	3	45	100	
A-SEM3120L-R0,5	12	12	0,5	50	110	
A-SEM3120L-R1	12	12	1	50	110	
A-SEM3120L-R2,5	12	12	2,5	50	110	
A-SEM3120L-R4	12	12	4	50	110	
A-SEM3160L-R1	16	16	1	50	110	
A-SEM3160L-R2,5	16	16	2,5	50	110	
A-SEM3160L-R4	16	16	4	50	110	
A-SEM3200L-R2,5	20	20	2,5	50	130	
A-SEM3200L-R4	20	20	4	50	130	

Z3 HELICE 45° ZRN Serie Larga

FRESA TÓRICA ALUMINIO / RECUBRIMIENTO ZRN

EN Z3 HELICE 45° CORNER RADIUS ALUMINIUM END MILL | ZRN COATED | Long Series

FR Z3 HELICE 45° FRAISE TORIQUE À BOUT HÉMISPHERIQUE ALUMINIUM | REVÊTEMENT ZRN | Longue

DE Z3 HELICE 45° TORUSFRÄSER ALUMINIUM | OHNE BESCHICHTUNG ZRN | Lange

ES Aluminio, cobre, latón, bronce y termoplásticos.

EN Aluminium, copper, brass, bronze and thermoplastics.

FR Aluminium, cuivre, laiton, bronze et thermoplastiques.

DE Aluminium, kupfer, messing, bronze und kunststoffe.

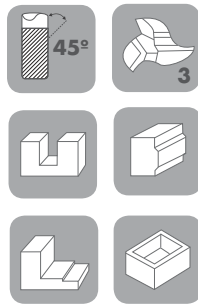

ZRN



SERIE LARGA ZRN

Ref.	Dimensiones (mm)					Precio €
	Dc	d	R	Lc	L	
3 Flutes (Z3)						
A-SEM3060L-R0,5_Z	6	6	0,5	25	80	
A-SEM3060L-R1_Z	6	6	1	25	80	
A-SEM3080L-R0,5_Z	8	8	0,5	35	90	
A-SEM3080L-R1_Z	8	8	1	35	90	
A-SEM3100L-R0,5_Z	10	10	0,5	45	100	
A-SEM3100L-R1_Z	10	10	1	45	100	
A-SEM3100L-R2_Z	10	10	2	45	100	
A-SEM3100L-R3_Z	10	10	3	45	100	
A-SEM3120L-R0,5_Z	12	12	0,5	50	110	
A-SEM3120L-R1_Z	12	12	1	50	110	
A-SEM3120L-R2,5_Z	12	12	2,5	50	110	
A-SEM3120L-R4_Z	12	12	4	50	110	
A-SEM3160L-R1_Z	16	16	1	50	110	
A-SEM3160L-R2,5_Z	16	16	2,5	50	110	
A-SEM3160L-R4_Z	16	16	4	50	110	
A-SEM3200L-R2,5_Z	20	20	2,5	50	130	
A-SEM3200L-R4_Z	20	20	4	50	130	

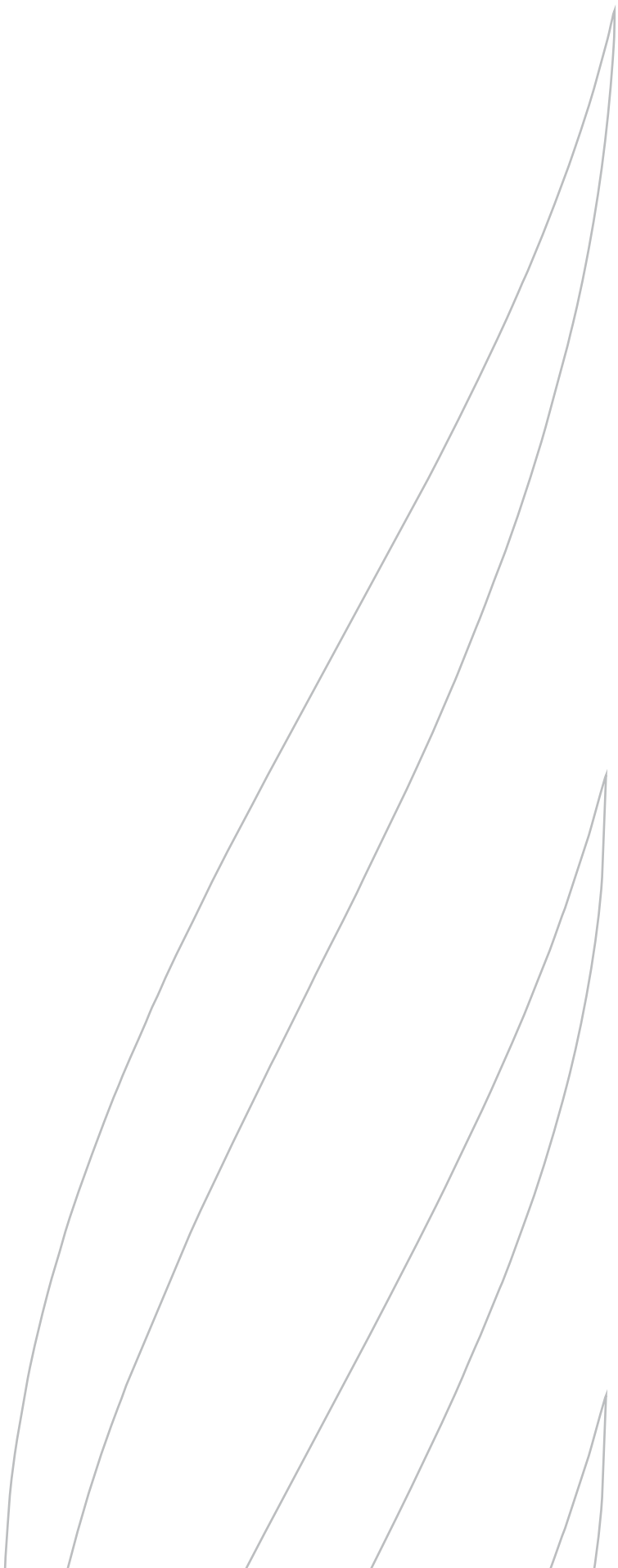



02

FRESAS de frente recto

SQUARE END MILL
FRAISE CYLINDRIQUE EN BOUT
LANGLOCHFRÄSER

I Z2 FRESA FRENTE RECTO Serie Normal

EN Z2 SQUARE END MILL | Normal Series

FR Z2 FRAISE CYLINDRIQUE EN BOUT | Normale

DE Z2 LANGLOCHFRÄFER | Normale

ES Acero, Acero Inoxidable, Fundición Gris, Cobre, Titanio y Aceros hasta 56 HRC.

EN Steel, Stainless Steel, Cast Iron, Cooper, Titanium and Hardened Steels up to 56 HRC.

FR Acier, Acier Inoxydable, Fonte Grise, Cuivre, Titane et Acier Jusqu'à 56 HRC.

DE Stahl, Rostfreier Stahl, Gubeisen, Kupfer, Titan, Gehärteter Stahl 56 HRC.

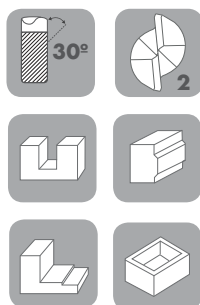

ALTiN

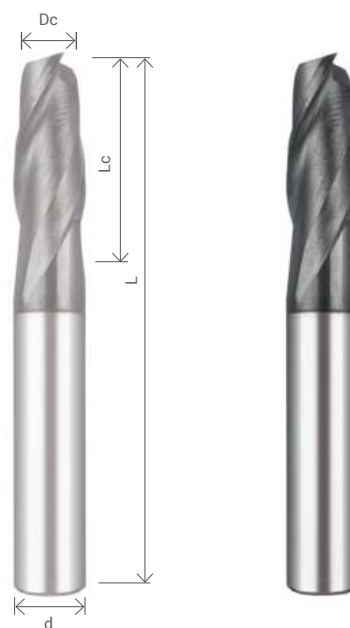

SERIE NORMAL

Ref.	Dimensiones (mm)					Precio €
	Dc	d	Lc	L		
2 Flutes (Z2)						
H-SEM2010-d3	1	3	3	38		
H-SEM2010-d4	1	4	3	50		
H-SEM2015-d3	1,5	3	4	38		
H-SEM2015-d4	1,5	4	4	50		
H-SEM2020-d3	2	3	6	38		
H-SEM2020-d4	2	4	6	50		
H-SEM2025-d3	2,5	3	8	38		
H-SEM2025-d4	2,5	4	8	50		
H-SEM2030-d3	3	3	8	38		
H-SEM2030-d4	3	4	8	50		
H-SEM2030-d6	3	6	8	50		
H-SEM2035-d4	3,5	4	11	50		
H-SEM2040-d4	4	4	11	50		
H-SEM2040-d6	4	6	11	50		
H-SEM2045-d6	4,5	6	11	50		

I Z2 FRESA FRENTE RECTO Serie Normal

EN Z2 SQUARE END MILL | Normal Series

FR Z2 FRAISE CYLINDRIQUE EN BOUT | Normale

DE Z2 LANGLOCHFRÄFER | Normale

Ref.	Dimensiones (mm)				Precio €
	Dc	d	Lc	L	
2 Flutes (Z2)					
H-SEM2050	5	5	13	50	
H-SEM2050-d6	5	6	13	50	
H-SEM2050-d6	5	6	13	50	
H-SEM2055-d6	5,5	6	16	50	
H-SEM2060	6	6	16	50	
H-SEM2063	6,35	8	19	60	
H-SEM2065	6,5	8	19	60	
H-SEM2070	7	8	19	60	
H-SEM2075	7,5	8	19	60	
H-SEM2080	8	8	19	60	
H-SEM2085	8,5	10	22	72	
H-SEM2090	9	10	22	72	
H-SEM2095	9,5	10	22	72	
H-SEM2100	10	10	22	72	
H-SEM2105	10,5	12	26	75	
H-SEM2110	11	12	26	75	
H-SEM2115	11,5	12	26	75	
H-SEM2120	12	12	26	75	
H-SEM2125	12,5	14	30	84	
H-SEM2130	13	14	30	84	
H-SEM2140	14	14	30	84	
H-SEM2150	15	16	32	92	
H-SEM2160	16	16	32	92	
H-SEM2170	17	18	38	100	
H-SEM2180	18	18	38	100	
H-SEM2185	18,5	20	38	100	
H-SEM2190	19	20	38	100	
H-SEM2200	20	20	38	100	
H-SEM2220	22	22	38	100	
H-SEM2250	25	25	45	100	

I Z2 FRESA FRENTE RECTO Serie Larga

- EN** Z2 SQUARE END MILL | Long Series
FR Z2 FRAISE CYLINDRIQUE EN BOUT | Longue
DE Z2 LANGLOCHFRÄFER | Lange

ES Acero, Acero Inoxidable, Fundición Gris, Cobre, Titanio y Aceros hasta 56 HRC.

EN Steel, Stainless Steel, Cast Iron, Cooper, Titanium and Hardened Steels up to 56 HRC.

FR Acier, Acier Inoxydable, Fonte Grise, Cuivre, Titane et Acier Jusq'ua 56 HRC.

DE Stahl, Rostfreier Stahl, Gubeisen, Kupfer, Titan, Gehärteter Stahl 56 HRC.

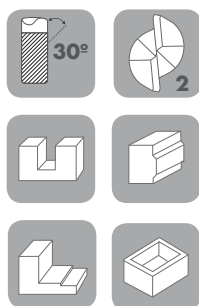

ALTiN



SERIE LARGA

Ref.	Dimensiones (mm)				Precio €
	Dc	d	Lc	L	
2 Flutes (Z2)					
H-SEM2010L	1	3	5	60	
H-SEM2015L	1,5	3	7	60	
H-SEM2020L	2	3	10	60	
H-SEM2030L	3	3	15	60	
H-SEM2040L	4	4	20	80	
H-SEM2050L	5	5	25	80	
H-SEM2060L	6	6	25	80	
H-SEM2080L	8	8	35	90	
H-SEM2090L	9	10	45	100	
H-SEM2100L	10	10	45	100	
H-SEM2120L	12	12	50	100	
H-SEM2140L	14	14	65	150	
H-SEM2160L	16	16	65	150	
H-SEM2200L	20	20	70	150	
H-SEM2250L	25	25	75	150	

Z2 FRESA FRENTE RECTO Serie Extra Larga

- EN** Z2 SQUARE END MILL | Extra Long Series
FR Z2 FRAISE CYLINDRIQUE EN BOUT | Extra Longue
DE Z2 LANGLOCHFRÄFER | Extra Lange

ES Acero, Acero Inoxidable, Fundición Gris, Cobre, Titanio y Aceros hasta 56 HRC.

EN Steel, Stainless Steel, Cast Iron, Cooper, Titanium and Hardened Steels up to 56 HRC.

FR Acier, Acier Inoxydable, Fonte Grise, Cuivre, Titane et Acier Jusq'ua 56 HRC.

DE Stahl, Rostfreier Stahl, Gubeisen, Kupfer, Titan, Gehärteter Stahl 56 HRC.

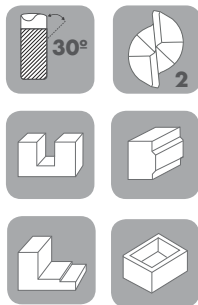

ALTiN



SERIE EXTRA LARGA

Ref.	Dimensiones (mm)				Precio €
	Dc	d	Lc	L	
2 Flutes (Z2)					
H-SEM2030LL	3	3	25	75	
H-SEM2040LL	4	4	25	100	
H-SEM2050LL	5	5	25	100	
H-SEM2060LL	6	6	25	100	
H-SEM2060XL	6	6	40	100	
H-SEM206LLL	6	6	25	150	
H-SEM2060XXL	6	6	40	150	
H-SEM2080XL	8	8	45	100	
H-SEM2080LL	8	8	25	150	
H-SEM2080XXL	8	8	45	150	
H-SEM2100LL	10	10	38	150	
H-SEM2100XL	10	10	50	150	
H-SEM2100XXL	10	10	65	150	
H-SEM2120LL	12	12	38	150	
H-SEM2120XL	12	12	50	150	
H-SEM2120XXL	12	12	75	150	
H-SEM2120LLL	12	12	38	200	

I Z3 FRESA FRENTE RECTO Serie Normal

- EN** Z3 SQUARE END MILL | Normal Series
FR Z3 FRAISE CYLINDRIQUE EN BOUT | Normale
DE Z3 LANGLOCHFRÄFER | Normale

- ES** Acero, Acero Inoxidable, Fundición Gris, Cobre, Titanio y Aceros hasta 56 HRC.
EN Steel, Stainless Steel, Cast Iron, Cooper, Titanium and Hardened Steels up to 56 HRC.
FR Acier, Acier Inoxydable, Fonte Grise, Cuivre, Titane et Acier Jusq'ua 56 HRC.
DE Stahl, Rostfreier Stahl, Gubeisen, Kupfer, Titan, Gehärteter Stahl 56 HRC.

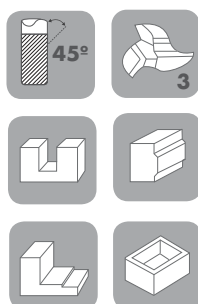

ALTIN

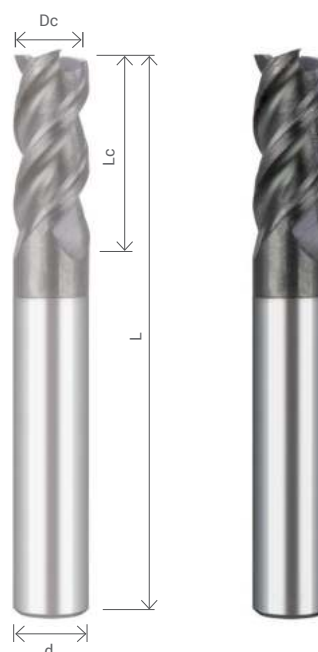

SERIE NORMAL

Ref.	Dimensiones (mm)				Precio €
	Dc	d	Lc	L	
3 Flutes (Z3)					
H-SEM3010-d3	1	3	3	38	
H-SEM3010-d4	1	4	3	50	
H-SEM3015-d3	1,5	3	4	38	
H-SEM3015-d4	1,5	4	4	50	
H-SEM3020-d3	2	3	6	38	
H-SEM3020-d4	2	4	6	50	
H-SEM3025-d3	2,5	3	8	38	
H-SEM3025-d4	2,5	4	8	50	
H-SEM3030-d3	3	3	8	38	
H-SEM3030-d4	3	4	8	50	
H-SEM3030-d6	3	6	8	50	
H-SEM3035-d4	3,5	4	8	50	
H-SEM3040-d4	4	4	11	50	
H-SEM3040-d6	4	6	11	50	

I Z3 FRESA FRENTE RECTO Serie Normal

EN Z3 SQUARE END MILL | Normal Series

FR Z3 FRAISE CYLINDRIQUE EN BOUT | Normale

DE Z3 LANGLOCHFRÄFER | Normale

Ref.	Dimensiones (mm)				Precio €
	Dc	d	Lc	L	
3 Flutes (Z3)					
H-SEM3045-d6	4,5	6	11	50	
H-SEM3050	5	5	13	50	
H-SEM3050-d6	5	6	13	50	
H-SEM3055-d6	5,5	6	16	50	
H-SEM3060	6	6	16	50	
H-SEM3063	6,35	8	19	60	
H-SEM3065	6,5	8	19	60	
H-SEM3070	7	8	19	60	
H-SEM3075	7,5	8	19	60	
H-SEM3080	8	8	19	60	
H-SEM3085	8,5	10	22	72	
H-SEM3090	9	10	22	72	
H-SEM3095	9,5	10	22	72	
H-SEM3100	10	10	22	72	
H-SEM3105	10,5	12	26	75	
H-SEM3110	11	12	26	75	
H-SEM3115	11,5	12	26	75	
H-SEM3120	12	12	26	75	
H-SEM3125	12,5	14	30	84	
H-SEM3130	13	14	30	84	
H-SEM3140	14	14	30	84	
H-SEM3150	15	16	32	92	
H-SEM3160	16	16	32	92	
H-SEM3170	17	18	38	100	
H-SEM3180	18	18	38	100	
H-SEM3185	18,5	20	38	100	
H-SEM3190	19	20	38	100	
H-SEM3200	20	20	38	100	
H-SEM3220	22	22	38	100	
H-SEM3250	25	25	45	100	

I Z3 FRESA FRENTE RECTO Serie Larga

- EN** Z3 SQUARE END MILL | Long Series
FR Z3 FRAISE CYLINDRIQUE EN BOUT | Longue
DE Z3 LANGLOCHFRÄFER | Lange

ES Acero, Acero Inoxidable, Fundición Gris, Cobre, Titanio y Aceros hasta 56 HRC.

EN Steel, Stainless Steel, Cast Iron, Cooper, Titanium and Hardened Steels up to 56 HRC.

FR Acier, Acier Inoxydable, Fonte Grise, Cuivre, Titane et Acier Jusq'ua 56 HRC.

DE Stahl, Rostfreier Stahl, Gubeisen, Kupfer, Titan, Gehärteter Stahl 56 HRC.

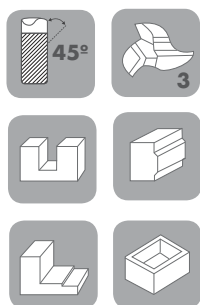

ALTiN

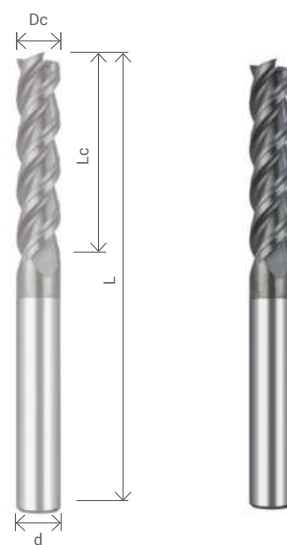

Ref.	Dimensiones (mm)				Precio €
	Dc	d	Lc	L	
3 Flutes (Z3)					
H-SEM3010L	1	3	5	60	
H-SEM3015L	1,5	3	7	60	
H-SEM3020L	2	3	10	60	
H-SEM3030L	3	3	15	60	
H-SEM3040L	4	4	20	80	
H-SEM3050L	5	5	25	80	
H-SEM3060L	6	6	25	80	
H-SEM3080L	8	8	35	90	
H-SEM3100L	10	10	45	100	
H-SEM3120L	12	12	50	100	
H-SEM3140L	14	14	65	150	
H-SEM3160L	16	16	65	150	
H-SEM3200L	20	20	70	150	
H-SEM3250L	25	25	75	150	

Z4 FRESA FRENTE RECTO Extra Larga

- EN** Z4 SQUARE END MILL | Extra Long Series
FR Z4 FRAISE CYLINDRIQUE EN BOUT | Extra Longue
DE Z4 LANGLOCHFRÄFER | Extra Lange

ES Acero, Acero Inoxidable, Fundición Gris, Cobre, Titanio y Aceros hasta 56 HRC.

EN Steel, Stainless Steel, Cast Iron, Cooper, Titanium and Hardened Steels up to 56 HRC.

FR Acier, Acier Inoxydable, Fonte Grise, Cuivre, Titane et Acier Jusq'ua 56 HRC.

DE Stahl, Rostfreier Stahl, Gubeisen, Kupfer, Titan, Gehärteter Stahl 56 HRC.

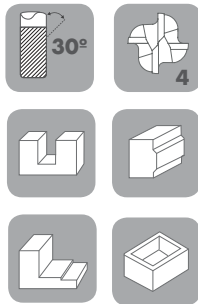

ALTiN

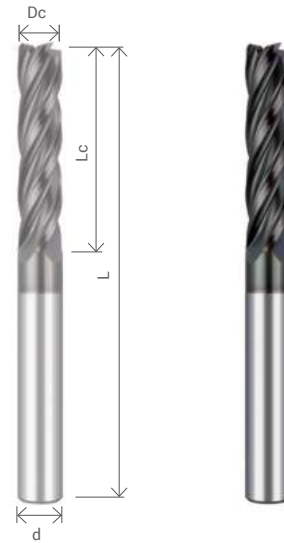

Ref.	Dimensiones (mm)				Precio €
	Dc	d	Lc	L	
4 Flutes (Z4)					
H-SEM4030LL	3	3	25	75	
H-SEM4030XL	3	3	25	100	
H-SEM4040LL	4	4	25	100	
H-SEM4050LL	5	5	25	100	
H-SEM4060LL	6	6	25	100	
H-SEM4060XL	6	6	40	100	
H-SEM4060LLL	6	6	25	150	
H-SEM4060XXL	6	6	40	150	
H-SEM4080XL	8	8	45	100	
H-SEM4080LL	8	8	25	150	
H-SEM4080XXL	8	8	45	150	
H-SEM4100LL	10	10	38	150	
H-SEM4100XL	10	10	50	150	
H-SEM4100XXL	10	10	65	150	
H-SEM4120LL	12	12	38	150	
H-SEM4120XL	12	12	50	150	
H-SEM4120XXL	12	12	75	150	
H-SEM4120LLL	12	12	38	200	

Z4 FRESA FRENTE RECTO Serie Normal

EN Z4 SQUARE END MILL | Normal Series

FR Z4 FRAISE CYLINDRIQUE EN BOUT | Normale

DE Z4 LANGLOCHFRÄFER | Normale

ES Acero, Acero Inoxidable, Fundición Gris, Cobre, Titanio y Aceros hasta 56 HRC.

EN Steel, Stainless Steel, Cast Iron, Cooper, Titanium and Hardened Steels up to 56 HRC.

FR Acier, Acier Inoxydable, Fonte Grise, Cuivre, Titane et Acier Jusqu'à 56 HRC.

DE Stahl, Rostfreier Stahl, Gubeisen, Kupfer, Titan, Gehärteter Stahl 56 HRC.

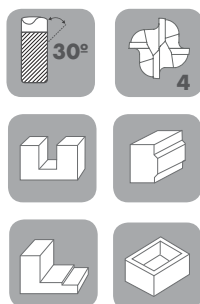

ALTiN

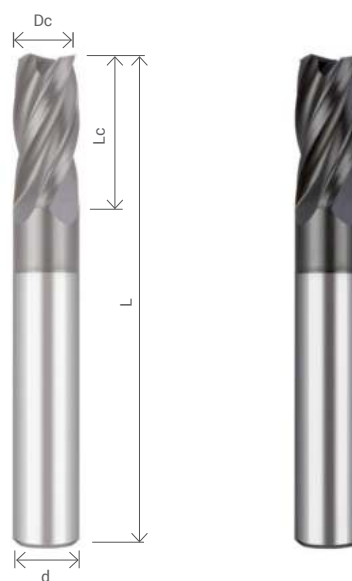

SERIE NORMAL

Ref.	Dimensiones (mm)				Precio €
	Dc	d	Lc	L	
4 Flutes (Z4)					
H-SEM4010-d3	1	3	3	38	
H-SEM4010-d4	1	4	3	50	
H-SEM4015-d3	1,5	3	4	38	
H-SEM4015-d4	1,5	4	4	50	
H-SEM4020-d3	2	3	6	38	
H-SEM4020-d4	2	4	6	50	
H-SEM4025-d3	2,5	3	8	38	
H-SEM4025-d4	2,5	4	8	50	
H-SEM4030-d3	3	3	8	38	
H-SEM4030-d4	3	4	8	50	
H-SEM4030-d6	3	6	8	50	
H-SEM4035-d4	3,5	4	8	50	
H-SEM4040-d4	4	4	11	50	
H-SEM4040-d6	4	6	11	50	
H-SEM4045-d6	4,5	6	11	50	
H-SEM4050	5	5	13	50	
H-SEM4050-d6	5	6	13	50	

Z4 FRESA FRENTE RECTO Serie Normal

Ref.	Dimensiones (mm)				Precio €
	Dc	d	Lc	L	
4 Flutes (Z4)					
H-SEM4055-d6	5,5	6	16	50	
H-SEM4060	6	6	16	50	
H-SEM4060S	6	6	22	58	
H-SEM4063	6,35	8	19	60	
H-SEM4065	6,5	8	19	60	
H-SEM4070	7	8	19	60	
H-SEM4075	7,5	8	19	60	
H-SEM4080	8	8	19	60	
H-SEM4085	8,5	10	22	72	
H-SEM4090	9	10	22	72	
H-SEM4095	9,5	10	22	72	
H-SEM4100	10	10	22	72	
H-SEM4100S	10	10	32	80	
H-SEM4105	10,5	12	26	75	
H-SEM4110	11	12	26	75	
H-SEM4115	11,5	12	26	75	
H-SEM4120	12	12	26	75	
H-SEM4120S	12	12	32	75	
H-SEM4125	12,5	14	30	84	
H-SEM4130	13	14	30	84	
H-SEM4140	14	14	30	84	
H-SEM4140S	14	14	50	100	
H-SEM4150	15	16	32	92	
H-SEM4160	16	16	32	92	
H-SEM4160S	16	16	50	100	
H-SEM4170	17	18	38	100	
H-SEM4180	18	18	38	100	
H-SEM4180S	18	18	50	100	
H-SEM4185	18,5	20	38	100	
H-SEM4190	19	20	38	100	
H-SEM4200	20	20	38	100	
H-SEM4200S	20	20	50	100	
H-SEM4220	22	22	38	100	
H-SEM4250	25	25	45	100	
H-SEM4250S	25	25	55	110	

I Z4 FRESA FRETE RECTO Serie Larga

- EN** Z4 SQUARE END MILL | Long Series
FR Z4 FRAISE CYLINDRIQUE EN BOUT | Longue
DE Z4 LANGLOCHFRÄFER | Lange

- ES** Acero, Acero Inoxidable, Fundición Gris, Cobre, Titanio y Aceros hasta 56 HRC.
- EN** Steel, Stainless Steel, Cast Iron, Cooper, Titanium and Hardened Steels up to 56 HRC.
- FR** Acier, Acier Inoxydable, Fonte Grise, Cuivre, Titane et Acier Jusqu'à 56 HRC.
- DE** Stahl, Rostfreier Stahl, Gubeisen, Kupfer, Titan, Gehärteter Stahl 56 HRC.

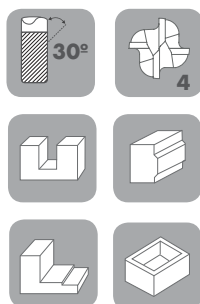

ALTiN



SERIE LARGA

Ref.	Dimensiones (mm)				Precio €
	Dc	d	Lc	L	
4 Flutes (Z4)					
H-SEM4010L	1	3	5	60	
H-SEM4015L	1,5	3	7	60	
H-SEM4020L	2	3	10	60	
H-SEM4030L	3	3	15	60	
H-SEM4040L	4	4	20	80	
H-SEM4050L	5	5	25	80	
H-SEM4060L	6	6	25	80	
H-SEM4070L	7	8	35	90	
H-SEM4080L	8	8	35	90	
H-SEM4090L	9	10	45	100	
H-SEM4100L	10	10	45	100	
H-SEM4120L	12	12	50	100	
H-SEM4140L	14	14	65	150	
H-SEM4140LL	14	14	90	150	
H-SEM4160L	16	16	65	150	

I Z4 FRESA FRENTE RECTO Serie Larga

- EN** Z4 SQUARE END MILL | Long Series
FR Z4 FRAISE CYLINDRIQUE EN BOUT | Longue
DE Z4 LANGLOCHFRÄFER | Lange



Ref.	Dimensiones (mm)				Precio €
	Dc	d	Lc	L	
4 Flutes (Z4)					
H-SEM4160LL	16	16	90	150	
H-SEM4180L	18	18	70	150	
H-SEM4200L	20	20	70	150	
H-SEM4200LL	20	20	90	150	
H-SEM4200XL	20	20	100	165	
H-SEM4200XLL	20	20	110	200	
H-SEM4250L	25	25	75	150	

Z6 FRESA MULTILABIO Serie Normal

EN Z6 MULTI FLUTE END MILL | Normal Series

FR Z6 FRAISE CYLINDRIQUE MULTIDENTS | Normale

DE Z6 SCHAFTFRÄSER MEHRSCHEIDEN | Normale

ES Acero, Acero Inoxidable, Fundición Gris, Cobre, Titanio y Aceros hasta 65 HRC.

EN Steel, Stainless Steel, Cast Iron, Cooper, Titanium and Hardened Steels up to 65 HRC.

FR Acier, Acier Inoxydable, Fonte Grise, Cuivre, Titane et Acier Jusqu'à 65 HRC.

DE Stahl, Rostfreier Stahl, Gubeisen, Kupfer, Titan, Gehärteter Stahl 65 HRC.

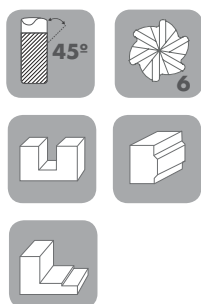

ALTIM NANO

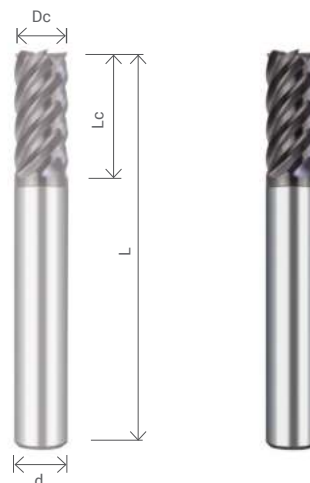

Ref.	Dimensiones (mm)				Precio €
	Dc	d	Lc	L	
6 Flutes (Z6)					
H-HEM4030-Z4	3.0	3	8	38	
H-HEM4040-Z4	4.0	4	11	50	
H-HEM4050-Z4	5.0	5	13	50	
H-HEM6060	6.0	6	16	50	
H-HEM6080	8.0	8	19	60	
H-HEM6100	10.0	10	22	75	
H-HEM6120	12.0	12	26	75	
H-HEM6140	14.0	14	32	90	
H-HEM6160	16.0	16	32	100	
H-HEM6160S	16.0	16	50	100	
H-HEM6180	18.0	18	38	100	
H-HEM6200	20.0	20	38	100	
H-HEM6200S	20.0	20	50	100	
H-HEM6250	25.0	25	38	100	

Z6 FRESA MULTILABIO Series Larga y Extra Larga

EN Z6 MULTI FLUTE END MILL | Long & Extra Long Series

FR Z6 FRAISE CYLINDRIQUE MULTIDENTS | Longue & Extra Longue

DE Z6 SCHAFTFRÄSER MEHRSCHEIDEN | Lange & Extra Lange

ES Acero, Acero Inoxidable, Fundición Gris, Cobre, Titanio y Aceros hasta 65 HRC.

EN Steel, Stainless Steel, Cast Iron, Cooper, Titanium and Hardened Steels up to 65 HRC.

FR Acier, Acier Inoxydable, Fonte Grise, Cuivre, Titane et Acier Jusq'ua 65 HRC.

DE Stahl, Rostfreier Stahl, Gubeisen, Kupfer, Titan, Gehärteter Stahl 65 HRC.

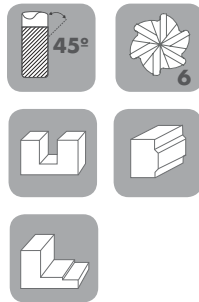

ALTiN NANO



Ref.	Dimensiones (mm)				Precio €
	Dc	d	Lc	L	
6 Flutes (Z6)					
H-HEM4030L-Z4	3.0	3	15	60	
H-HEM4040L-Z4	4.0	4	20	80	
H-HEM4050L-Z4	5.0	5	25	80	
H-HEM6060L	6.0	6	25	80	
H-HEM6080L	8.0	8	35	90	
H-HEM6100L	10.0	10	45	100	
H-HEM6120L	12.0	12	50	100	
H-HEM6120LL	12.0	12	70	125	
H-HEM6140L	14.0	14	65	150	
H-HEM6160L	16.0	16	65	150	
H-HEM6160LL	16.0	16	100	165	
H-HEM6200L	20.0	20	70	150	
H-HEM6200LL	20.0	20	100	165	
H-HEM6200LLL	20.0	20	135	200	
H-HEM6250L	25.0	25	75	150	
H-HEM6250LL	25.0	25	100	165	
H-HEM6250LLL	25.0	25	140	200	
H-HEM6320LL	32.0	32	100	165	
H-HEM6320LLL	32.0	32	150	210	

I Z3 y Z4 FRESA DE SEMIDESBASTE FRENTE RECTO Serie Normal

EN Z3-Z4 SEMI-ROUGHING END MILL | Normal Series

FR Z3-Z4 FRAISE CYLINDRIQUE EN BOUT. SEMI-FINITION | Normale

DE Z3-Z4 SCHRUPPSCHLICHTFRÄSER | Normale

ES Acero, Acero Inoxidable, Fundición Gris, Cobre, Titanio y Aceros hasta 56 HRC.

EN Steel, Stainless Steel, Cast Iron, Cooper, Titanium and Hardened Steels up to 56 HRC.

FR Acier, Acier Inoxydable, Fonte Grise, Cuivre, Titane et Acier Jusqu'à 56 HRC.

DE Stahl, Rostfreier Stahl, Gubeisen, Kupfer, Titan, Gehärteter Stahl 56 HRC.

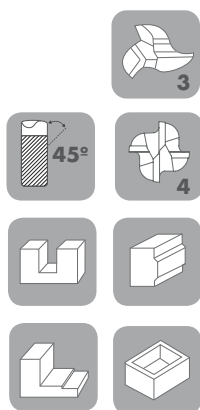

ALTIN

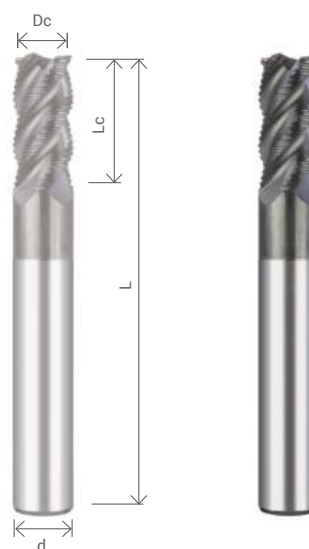

SERIE NORMAL

Ref.	Ref.	Dimensiones (mm)				Precio €
		Dc	d	Lc	L	
3 Flutes (Z3)	4 Flutes (Z4)					
BW-SEM3060	BW-SEM4060	6	6	16	50	
BW-SEM3080	BW-SEM4080	8	8	19	60	
	BW-SEM4100	10	10	22	75	
	BW-SEM4120	12	12	26	75	
	BW-SEM4140	14	14	30	84	
	BW-SEM4160	16	16	32	92	
	BW-SEM4180	18	18	38	100	
	BW-SEM4200	20	20	38	100	

Z4 FRESA DE SEMIDESBASTE FRENTE RECTO Serie Larga

- EN** Z4 SEMI-ROUGHING END MILL | Long Series
FR Z4 FRAISE CYLINDRIQUE EN BOUT. SEMI-FINITION | Longue
DE Z4 SCHRUPPSCHLICHTFRÄSER | Lange

ES Acero, Acero Inoxidable, Fundición Gris, Cobre, Titanio y Aceros hasta 56 HRC.

EN Steel, Stainless Steel, Cast Iron, Cooper, Titanium and Hardened Steels up to 56 HRC.

FR Acier, Acier Inoxydable, Fonte Grise, Cuivre, Titane et Acier Jusq'ua 56 HRC.

DE Stahl, Rostfreier Stahl, Gubeisen, Kupfer, Titan, Gehärteter Stahl 56 HRC.

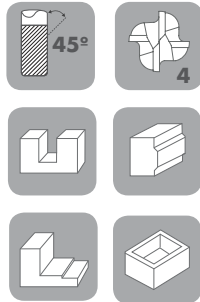

ALTiN

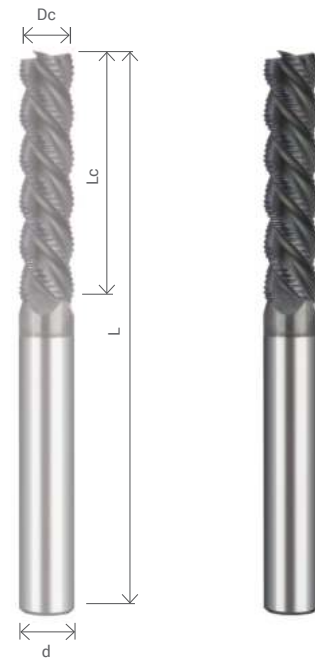

SERIE LARGA

Ref.	Dimensiones (mm)				Precio €
	Dc	d	Lc	L	
4 Flutes (Z4)					
BW-SEM4060L	6	6	25	80	
BW-SEM4080L	8	8	35	90	
BW-SEM4100L	10	10	45	100	
BW-SEM4120L	12	12	50	100	
BW-SEM4160L	16	16	65	150	
BW-SEM4200L	20	20	70	150	

I Z2 FRESA FRONTAL CUELLO REBAJADO / MANGO 6

- EN** Z2 END MILLS,
FR Z2 FRAISE CYLINDRIQUE
DE Z2 LANGLOCHFRÄSER

- ES** Acero, Acero Inoxidable, Fundición Gris, Cobre, Titanio y Aceros hasta 56 HRC.
- EN** Steel, Stainless Steel, Cast Iron, Cooper, Titanium and Hardened Steels up to 56 HRC.
- FR** Acier, Acier Inoxydable, Fonte Grise, Cuivre, Titane et Acier Jusq'ua 56 HRC.
- DE** Stahl, Rostfreier Stahl, Gubeisen, Kupfer, Titan, Gehärteter Stahl 56 HRC.

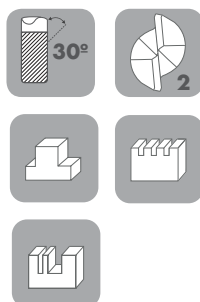

ALTIN NANO

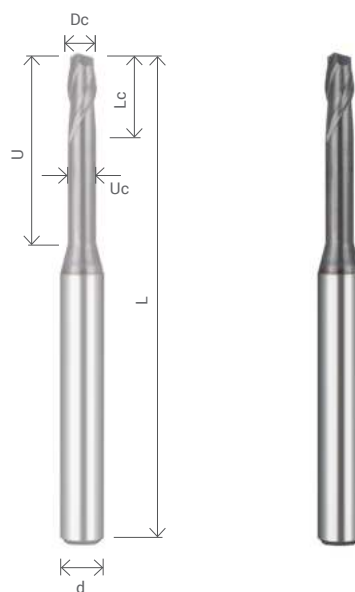

SHANK d6

Ref.	Dimensiones (mm)						Precio €
	Dc	d	U/C	U	Lc	L	
2 Flutes (Z2)							
H-SEM2010-05	1	6	0,95	5	1,5	57	
H-SEM2010-08	1	6	0,95	8	1,5	57	
H-SEM2010-10	1	6	0,95	10	1,5	57	
H-SEM2010-12	1	6	0,95	12	1,5	65	
H-SEM2010-15	1	6	0,95	15	1,5	65	
H-SEM2010-20	1	6	0,95	20	1,5	65	
H-SEM2015-05	1,5	6	1,42	5	2	57	
H-SEM2015-08	1,5	6	1,42	8	2	57	
H-SEM2015-10	1,5	6	1,42	10	2	57	
H-SEM2015-12	1,5	6	1,42	12	2	65	
H-SEM2015-15	1,5	6	1,42	15	2	65	
H-SEM2015-20	1,5	6	1,42	20	2	65	
H-SEM2015-25	1,5	6	1,42	25	2	65	
H-SEM2020-06	2	6	1,92	6	3	57	
H-SEM2020-08	2	6	1,92	8	3	57	
H-SEM2020-10	2	6	1,92	10	3	57	

Ref.	Dimensiones (mm)						Precio €
	Dc	d	U/C	l1	Lc	L	
2 Flutes (Z2)							
H-SEM2020-12	2	6	1,92	12	3	60	
H-SEM2020-14	2	6	1,92	14	3	65	
H-SEM2020-16	2	6	1,92	16	3	65	
H-SEM2020-20	2	6	1,92	20	3	65	
H-SEM2020-25	2	6	1,92	25	3	65	
H-SEM2020-30	2	6	1,92	30	3	80	
H-SEM2020-35	2	6	1,92	35	2	80	
H-SEM2020-40	2	6	1,92	40	3	80	
H-SEM2020-50	2	6	1,92	50	3	100	
H-SEM2025-10	2,5	6	2,4	10	4	57	
H-SEM2025-16	2,5	6	2,4	16	4	65	
H-SEM2025-20	2,5	6	2,4	20	4	65	
H-SEM2025-30	2,5	6	2,4	30	4	80	
H-SEM2025-40	2,5	6	2,4	40	4	80	
H-SEM2030-09	3	6	2,9	9	5	57	
H-SEM2030-12	3	6	2,9	12	5	60	
H-SEM2030-15	3	6	2,9	15	5	65	
H-SEM2030-20	3	6	2,9	20	5	65	
H-SEM2030-25	3	6	2,9	25	5	65	
H-SEM2030-30	3	6	2,9	30	5	80	
H-SEM2030-35	3	6	2,9	35	5	80	
H-SEM2030-40	3	6	2,9	40	5	80	
H-SEM2030-50	3	6	2,9	50	5	100	
H-SEM2040-10	4	6	3,9	10	6	57	
H-SEM2040-12	4	6	3,9	12	6	60	
H-SEM2040-16	4	6	3,9	16	6	65	
H-SEM2040-20	4	6	3,9	20	6	65	
H-SEM2040-25	4	6	3,9	25	6	65	
H-SEM2040-30	4	6	3,9	30	6	80	
H-SEM2040-35	4	6	3,9	35	6	80	
H-SEM2040-40	4	6	3,9	40	6	80	
H-SEM2040-50	4	6	3,9	50	6	100	
H-SEM2050-12	5	6	4,8	12	7	60	
H-SEM2050-20	5	6	4,8	20	7	65	
H-SEM2050-30	5	6	4,8	30	7	80	
H-SEM2050-40	5	6	4,8	40	7	80	
H-SEM2050-50	5	6	4,8	50	7	100	

I Z4 FRESA FRONTAL CUELLO REBAJADO / MANGO 6

EN Z4 END MILLS | REDUCED NECK

FR Z4 FRAISE CYLINDRIQUE | REDUCED NECK

DE Z4 LANGLOCHFRÄSER | REDUCED NECK

ES Acero, Acero Inoxidable, Fundición Gris, Cobre, Titanio y Aceros hasta 56 HRC.

EN Steel, Stainless Steel, Cast Iron, Cooper, Titanium and Hardened Steels up to 56 HRC.

FR Acier, Acier Inoxydable, Fonte Grise, Cuivre, Titane et Acier Jusq'ua 56 HRC.

DE Stahl, Rostfreier Stahl, Gubeisen, Kupfer, Titan, Gehärteter Stahl 56 HRC.

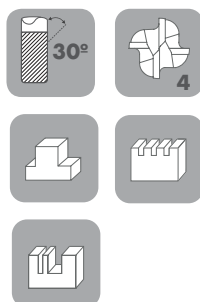

ALTIN NANO

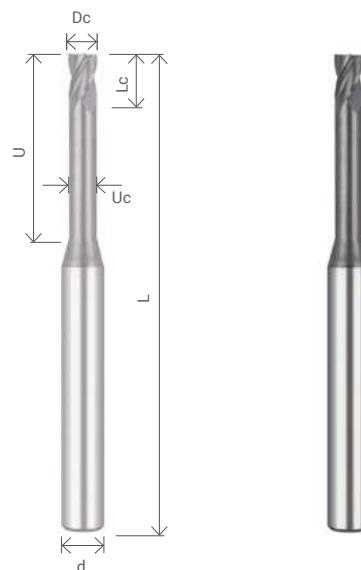

SHANK d6

Ref.	Dimensiones (mm)						Precio €
	Dc	d	U/C	U	Lc	L	
4 Flutes (Z4)							
H-SEM4020-06	2	6	1,92	6	3	57	
H-SEM4020-08	2	6	1,92	8	3	57	
H-SEM4020-10	2	6	1,92	10	3	57	
H-SEM4020-12	2	6	1,92	12	3	60	
H-SEM4020-14	2	6	1,92	14	3	65	
H-SEM4020-16	2	6	1,92	16	3	65	
H-SEM4020-20	2	6	1,92	20	3	65	
H-SEM4020-25	2	6	1,92	25	3	65	
H-SEM4020-30	2	6	1,92	30	3	80	
H-SEM4020-35	2	6	1,92	35	2	80	
H-SEM4020-40	2	6	1,92	40	3	80	
H-SEM4020-50	2	6	1,92	50	3	100	
H-SEM4025-10	2,5	6	2,4	10	4	57	
H-SEM4025-16	2,5	6	2,4	16	4	65	

I Z4 FRESA FRONTAL CUELLO REBAJADO / MANGO 6

EN Z4 END MILLS | REDUCED NECK

FR Z4 FRAISE CYLINDRIQUE | REDUCED NECK

DE Z4 LANGLOCHFRÄSER | REDUCED NECK



Ref.	Dimensiones (mm)						Precio €
	4 Flutes (Z4)	Dc	d	U/C	U	Lc	
H-SEM4025-20		2,5	6	2,4	20	4	65
H-SEM4025-30		2,5	6	2,4	30	4	80
H-SEM4025-40		2,5	6	2,4	40	4	80
H-SEM4030-09		3	6	2,9	9	5	57
H-SEM4030-12		3	6	2,9	12	5	60
H-SEM4030-15		3	6	2,9	15	5	65
H-SEM4030-20		3	6	2,9	20	5	65
H-SEM4030-25		3	6	2,9	25	5	65
H-SEM4030-30		3	6	2,9	30	5	80
H-SEM4030-35		3	6	2,9	35	5	80
H-SEM4030-40		3	6	2,9	40	5	80
H-SEM4030-50		3	6	2,9	50	5	100
H-SEM4040-10		4	6	3,9	10	6	57
H-SEM4040-12		4	6	3,9	12	6	60
H-SEM4040-16		4	6	3,9	16	6	65
H-SEM4040-20		4	6	3,9	20	6	65
H-SEM4040-25		4	6	3,9	25	6	65
H-SEM4040-30		4	6	3,9	30	6	80
H-SEM4040-35		4	6	3,9	35	6	80
H-SEM4040-40		4	6	3,9	40	6	80
H-SEM4040-50		4	6	3,9	50	6	100
H-SEM4050-12		5	6	4,8	12	7	60
H-SEM4050-20		5	6	4,8	20	7	65
H-SEM4050-30		5	6	4,8	30	7	80
H-SEM4050-40		5	6	4,8	40	7	80
H-SEM4050-50		5	6	4,8	50	7	100

I Z2 MICROFRESA FRONTAL SIN CUELLO / MANGO 4

- EN** Z2 MICRO END MILLS | Without Neck
FR Z2 MICROFRAISE CYLINDRIQUE | Without Neck
DE Z2 MIKROLANGLOCHFRÄSER | Without Neck

- ES** Acero, Acero Inoxidable, Fundición Gris, Cobre, Titanio y Aceros hasta 56 HRC.
EN Steel, Stainless Steel, Cast Iron, Cooper, Titanium and Hardened Steels up to 56 HRC.
FR Acier, Acier Inoxydable, Fonte Grise, Cuivre, Titane et Acier Jusqu'à 56 HRC.
DE Stahl, Rostfreier Stahl, Gubeisen, Kupfer, Titan, Gehärteter Stahl 56 HRC.

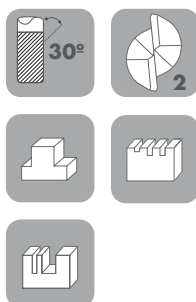

ALTIM NANO



SIN CUELLO

Ref.	Dimensiones (mm)				Precio €
2 Flutes (Z2)	D	d	Lc	L	
M-SEM2002	0,2	4	0,4	50	
M-SEM2003	0,3	4	0,6	50	
M-SEM2004	0,4	4	0,8	50	
M-SEM2005	0,5	4	1	50	
M-SEM2006	0,6	4	1,2	50	
M-SEM2007	0,7	4	1,4	50	
M-SEM2008	0,8	4	1,6	50	
M-SEM2009	0,9	4	1,8	50	

Z2 MICROFRESA FRONTAL CUELLO REBAJADO / MANGO 4

- EN** Z2 MICRO END MILLS | REDUCED NECK
FR Z2 MICROFRAISE CYLINDRIQUE | REDUCED NECK
DE Z2 MIKROLANGLOCHFRÄSER | REDUCED NECK

- ES** Acero, Acero Inoxidable, Fundición Gris, Cobre, Titanio y Aceros hasta 56 HRC.
EN Steel, Stainless Steel, Cast Iron, Cooper, Titanium and Hardened Steels up to 56 HRC.
FR Acier, Acier Inoxydable, Fonte Grise, Cuivre, Titane et Acier Jusq'ua 56 HRC.
DE Stahl, Rostfreier Stahl, Gubeisen, Kupfer, Titan, Gehärteter Stahl 56 HRC.

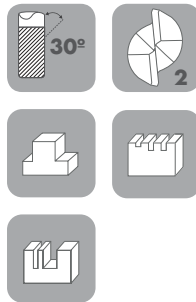

ALTiN NANO

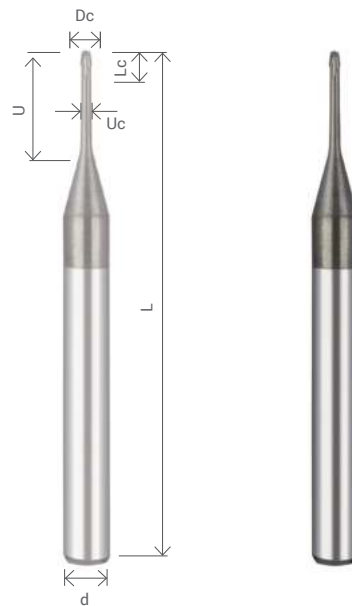

CON CUELLO REBAJADO

Ref.	Dimensiones (mm)						Precio €
	D	d	U/C	U	Lc	L	
2 Flutes (Z2)							
H-MEM2005-04	0,5	4	0,48	4	0,7	50	
H-MEM2005-06	0,5	4	0,48	6	0,7	50	
H-MEM2006-04	0,6	4	0,57	4	0,9	50	
H-MEM2006-06	0,6	4	0,57	6	0,9	50	
H-MEM2006-08	0,6	4	0,57	8	0,9	50	
H-MEM2008-06	0,8	4	0,76	6	1,2	50	
H-MEM2008-08	0,8	4	0,76	8	1,2	50	
H-MEM2008-10	0,8	4	0,76	10	1,2	50	
H-MEM2012-06	1,2	4	1,15	6	1,8	50	
H-MEM2012-08	1,2	4	1,15	8	1,8	50	
H-MEM2012-10	1,2	4	1,15	10	1,8	50	





03

FRESAS esféricas

BALL NOSE END MILL
FRAISE CYLINDRIQUE HÉMISPHERIQUE
KUGELFRÄSER

I Z2 FRESAS ESFERICAS Serie Normal

EN Z2 BALL NOSE END MILL | Normal series

FR Z2 FRAISE CYLINDRIQUE HÉMISPHERIQUE | Normale

DE Z2 KUGELFRÄSER | Normale

ES Acero, Acero Inoxidable, Fundición Gris, Cobre, Titanio y Aceros hasta 62 HRC.

EN Steel, Stainless Steel, Cast Iron, Cooper, Titanium and Hardened Steels up to 62 HRC.

FR Acier, Acier Inoxydable, Fonte Grise, Cuivre, Titane et Acier Jusq'ua 62 HRC.

DE Stahl, Rostfreier Stahl, Gubeisen, Kupfer, Titan, Gehärteter Stahl 62 HRC.



ALTIN NANO

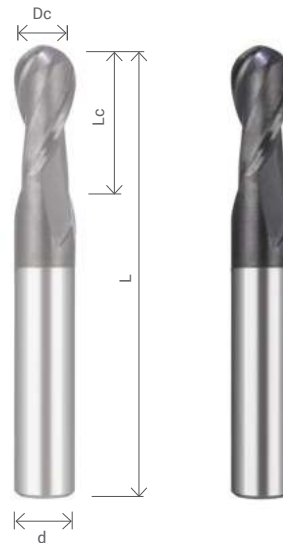

SERIE NORMAL

Ref.	Dimensiones (mm)				Precio €
	Dc	d	Lc	L	
2 Flutes (Z2)					
H-SBM2010-d3	1	3	2	38	
H-SBM2010-d4	1	4	2	50	
H-SBM2015-d3	1,5	3	3	38	
H-SBM2015-d4	1,5	4	3	50	
H-SBM2020-d3	2	3	4	38	
H-SBM2020-d4	2	4	4	50	
H-SBM2025-d3	2,5	3	5	38	
H-SBM2030-d3	3	3	6	38	
H-SBM2030-d4	3	4	6	50	
H-SBM2040	4	4	8	50	
H-SBM2050	5	5	10	50	
H-SBM2060	6	6	12	50	
H-SBM2070	7	8	15	60	
H-SBM2080	8	8	15	60	
H-SBM2100	10	10	20	75	
H-SBM2120	12	12	20	75	

I Z2 FRESAS ESFERICAS Serie Normal

EN Z2 BALL NOSE END MILL | Normal series

FR Z2 FRAISE CYLINDRIQUE HÉMISPHERIQUE | Normale

DE Z2 KUGELFRÄSER | Normale



Ref.	Dimensiones (mm)				Precio €
	Dc	d	Lc	L	
2 Flutes (Z2)					
H-SBM2140	14	14	25	90	
H-SBM2160	16	16	25	100	
H-SBM2180	18	18	30	100	
H-SBM2200	20	20	30	100	

Z2 FRESAS ESFERICAS Serie Larga

- EN** Z2 BALL NOSE END MILL | Long series
FR Z2 FRAISE CYLINDRIQUE HÉMISPHERIQUE | Longue
DE Z2 KUGELFRÄSER | Lange

- ES** Acero, Acero Inoxidable, Fundición Gris, Cobre, Titanio y Aceros hasta 62 HRC.
- EN** Steel, Stainless Steel, Cast Iron, Cooper, Titanium and Hardened Steels up to 62 HRC.
- FR** Acier, Acier Inoxydable, Fonte Grise, Cuivre, Titane et Acier Jusqu'à 62 HRC.
- DE** Stahl, Rostfreier Stahl, Gubeisen, Kupfer, Titan, Gehärteter Stahl 62 HRC.



ALTIM NANO

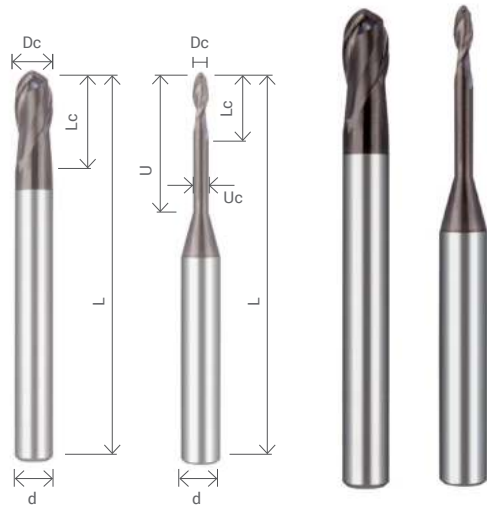

SERIE LARGA

Ref.	Dimensiones (mm)						Precio €
	Dc	d	U/C	U	Lc	L	
2 Flutes (Z2)							
H-SBM2010L	1	3	0,9	6	2	60	
H-SBM2015L	1,5	3	1,4	8	3	60	
H-SBM2020L	2	3	1,9	8	3	60	
H-SBM2025L	2,5	3	2,4	12	3	60	
H-SBM2030L	3	3	-	-	4	60	
H-SBM2040L	4	4	-	-	5	80	
H-SBM2050L	5	5	-	-	6	80	
H-SBM2060L	6	6	-	-	8	80	
H-SBM2080L	8	8	-	-	12	100	
H-SBM2100L	10	10	-	-	15	100	
H-SBM2120L	12	12	-	-	15	100	
H-SBM2140L	14	14	-	-	20	150	
H-SBM2160L	16	16	-	-	20	150	
H-SBM2180L	18	18	-	-	25	150	
H-SBM2200L	20	20	-	-	25	150	

Z2 FRESAS ESFERICAS Serie Extra Larga

- EN** Z2 BALL NOSE END MILL | Extra long series
FR Z2 FRAISE CYLINDRIQUE HÉMISPHERIQUE | Extra Longue
DE Z2 KUGELFRÄSER | Extra Lange

- ES** Acero, Acero Inoxidable, Fundición Gris, Cobre, Titanio y Aceros hasta 62 HRC.
EN Steel, Stainless Steel, Cast Iron, Cooper, Titanium and Hardened Steels up to 62 HRC.
FR Acier, Acier Inoxydable, Fonte Grise, Cuivre, Titane et Acier Jusq'ua 62 HRC.
DE Stahl, Rostfreier Stahl, Gubeisen, Kupfer, Titan, Gehärteter Stahl 62 HRC.



ALTIN NANO



SERIE EXTRA LARGA

Ref.	Dimensiones (mm)				Precio €
	Dc	d	Lc	L	
2 Flutes (Z2)					
H-SBM2030LL	3	3	6	75	
H-SBM2030XL	3	3	6	100	
H-SBM2040LL	4	4	6	100	
H-SBM2050LL	5	5	6	100	
H-SBM2060LL	6	6	15	100	
H-SBM2060LLL	6	6	15	150	
H-SBM2060LLLL	6	6	30	200	
H-SBM2080LL	8	8	25	150	
H-SBM2080LLL	8	8	50	200	
H-SBM2100LL	10	10	25	150	
H-SBM2100LLL	10	10	50	200	
H-SBM2120LL	12	12	25	150	
H-SBM2120LLL	12	12	25	200	
H-SBM2140LL	14	14	50	200	
H-SBM2160LL	16	16	50	200	

I Z4 FRESAS ESFERICAS Serie Normal

- EN** Z4 BALL NOSE END MILL | Normal Series
FR Z4 FRAISE CYLINDRIQUE HÉMISPHERIQUE | Normale
DE Z4 KUGELFRÄSER | Normale

- ES** Acero, Acero Inoxidable, Fundición Gris, Cobre, Titanio y Aceros hasta 62 HRC.
- EN** Steel, Stainless Steel, Cast Iron, Cooper, Titanium and Hardened Steels up to 62 HRC.
- FR** Acier, Acier Inoxydable, Fonte Grise, Cuivre, Titane et Acier Jusq'ua 62 HRC.
- DE** Stahl, Rostfreier Stahl, Gubeisen, Kupfer, Titan, Gehärteter Stahl 62 HRC.



ALTiN NANO

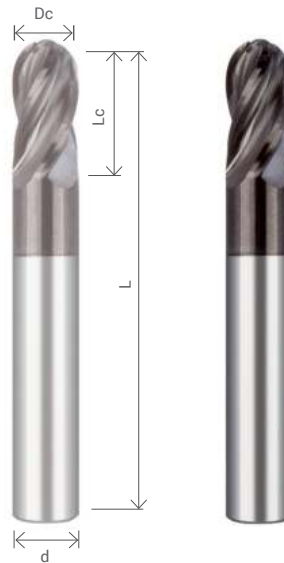

SERIE NORMAL

Ref.	Dimensiones (mm)				Precio €
	Dc	d	Lc	L	
4 Flutes (Z4)					
H-SBM4030	3	3	6	38	
H-SBM4040	4	4	8	50	
H-SBM4050	5	5	10	50	
H-SBM4060	6	6	12	50	
H-SBM4080	8	8	15	60	
H-SBM4100	10	10	20	75	
H-SBM4120	12	12	20	75	
H-SBM4140	14	14	25	90	
H-SBM4160	16	16	25	100	
H-SBM4180	18	18	30	100	
H-SBM4200	20	20	30	100	

I Z4 FRESAS ESFERICAS Serie Larga

- EN** Z4 BALL NOSE END MILL | Long Series
FR Z4 FRAISE CYLINDRIQUE HÉMISPHERIQUE | Longue
DE Z4 KUGELFRÄSER | Lange

- ES** Acero, Acero Inoxidable, Fundición Gris, Cobre, Titanio y Aceros hasta 62 HRC.
EN Steel, Stainless Steel, Cast Iron, Cooper, Titanium and Hardened Steels up to 62 HRC.
FR Acier, Acier Inoxydable, Fonte Grise, Cuivre, Titane et Acier Jusq'ua 62 HRC.
DE Stahl, Rostfreier Stahl, Gubeisen, Kupfer, Titan, Gehärteter Stahl 62 HRC.



ALTIN NANO

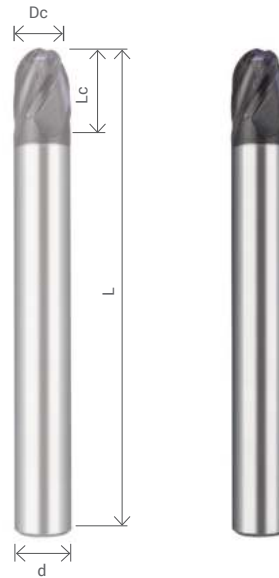

SERIE LARGA

Ref.	Dimensiones (mm)				Precio €
	Dc	d	Lc	L	
4 Flutes (Z4)					
H-SBM4030L	3	3	4	60	
H-SBM4040L	4	4	5	80	
H-SBM4050L	5	5	6	80	
H-SBM4060L	6	6	8	80	
H-SBM4080L	8	8	12	100	
H-SBM4100L	10	10	15	100	
H-SBM4120L	12	12	15	100	
H-SBM4160L	16	16	20	150	
H-SBM4200L	20	20	25	150	

I Z2 FRESAS ESFERICAS MANGO 4

- EN** Z2 BALL NOSE END MILL | REDUCED NECK
FR Z2 FRAISE CYLINDRIQUE HÉMISPHERIQUE
DE Z2 KUGELFRÄSER

- ES** Acero, Acero Inoxidable, Fundición Gris, Cobre, Titanio y Aceros hasta 62 HRC.
- EN** Steel, Stainless Steel, Cast Iron, Cooper, Titanium and Hardened Steels up to 62 HRC.
- FR** Acier, Acier Inoxydable, Fonte Grise, Cuivre, Titane et Acier Jusq'ua 62 HRC.
- DE** Stahl, Rostfreier Stahl, Gubeisen, Kupfer, Titan, Gehärteter Stahl 62 HRC.



ALTIN NANO

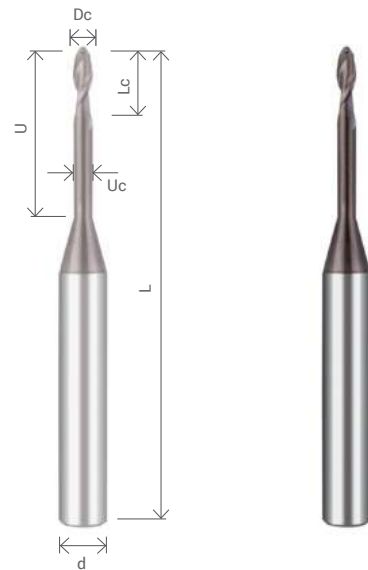

SHANK d4

Ref.	Dimensiones (mm)						Precio €
	Dc	d	U/C	U	Lc	L	
2 Flutes (Z2)							
H-NBM2010-04-d4	1	4	0,95	4	1,5	50	
H-NBM2010-06-d4	1	4	0,95	6	1,5	50	
H-NBM2010-08-d4	1	4	0,95	8	1,5	50	
H-NBM2010-10-d4	1	4	0,95	10	1,5	50	
H-NBM2010-12-d4	1	4	0,95	12	1,5	60	
H-NBM2010-16-d4	1	4	0,95	16	1,5	60	
H-NBM2010-20-d4	1	4	0,95	20	1,5	60	
H-NBM2015-04-d4	1,5	4	1,42	4	2	50	
H-NBM2015-06-d4	1,5	4	1,42	6	2	50	
H-NBM2015-08-d4	1,5	4	1,42	8	2	50	
H-NBM2015-10-d4	1,5	4	1,42	10	2	50	
H-NBM2015-12-d4	1,5	4	1,42	12	2	60	
H-NBM2015-16-d4	1,5	4	1,42	16	2	60	
H-NBM2015-20-d4	1,5	4	1,42	20	2	60	
H-NBM2015-25-d4	1,5	4	1,42	25	2	60	
H-NBM2020-06-d4	2	4	1,92	6	3	50	

Z2 FRESAS ESFERICAS MANGO 4

EN Z2 BALL NOSE END MILL | REDUCED NECK

FR Z2 FRAISE CYLINDRIQUE HÉMISPHERIQUE

DE Z2 KUGELFRÄSER



Ref.	Dimensiones (mm)						Precio €
2 Flutes (Z2)	Dc	d	U/C	l1	Lc	L	
H-NBM2020-08-d4	2	4	1,92	8	3	50	
H-NBM2020-10-d4	2	4	1,92	10	3	50	
H-NBM2020-12-d4	2	4	1,92	12	3	60	
H-NBM2020-16-d4	2	4	1,92	16	3	60	
H-NBM2020-20-d4	2	4	1,92	20	3	60	
H-NBM2020-25-d4	2	4	1,92	25	3	80	
H-NBM2020-30-d4	2	4	1,92	30	3	80	
H-NBM2020-35-d4	2	4	1,92	35	3	80	
H-NBM2020-40-d4	2	4	1,92	40	3	80	
H-NBM2030-08-d4	3	4	2,9	8	5	50	
H-NBM2030-10-d4	3	4	2,9	10	5	50	
H-NBM2030-12-d4	3	4	2,9	12	5	60	
H-NBM2030-16-d4	3	4	2,9	16	5	60	
H-NBM2030-20-d4	3	4	2,9	20	5	60	
H-NBM2030-25-d4	3	4	2,9	25	5	80	
H-NBM2030-30-d4	3	4	2,9	30	5	80	
H-NBM2030-35-d4	3	4	2,9	35	5	80	
H-NBM2030-40-d4	3	4	2,9	40	5	80	

I Z2 FRESAS ESFERICAS MANGO 6

- EN** Z2 BALL NOSE END MILL | REDUCED NECK
FR Z2 FRAISE CYLINDRIQUE HÉMISPHERIQUE
DE Z2 KUGELFRÄSER

- ES** Acero, Acero Inoxidable, Fundición Gris, Cobre, Titanio y Aceros hasta 62 HRC.
- EN** Steel, Stainless Steel, Cast Iron, Cooper, Titanium and Hardened Steels up to 62 HRC.
- FR** Acier, Acier Inoxydable, Fonte Grise, Cuivre, Titane et Acier Jusq'ua 62 HRC.
- DE** Stahl, Rostfreier Stahl, Gubeisen, Kupfer, Titan, Gehärteter Stahl 62 HRC.



ALTiN NANO

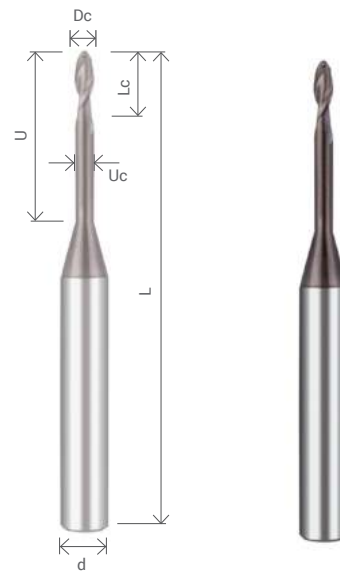

SHANK d6

Ref.	Dimensiones (mm)						Precio €
	Dc	d	U/C	U	Lc	L	
2 Flutes (Z2)							
H-NBM2010-U05	1	6	0,95	5	1,5	55	
H-NBM2010-U08	1	6	0,95	8	1,5	57	
H-NBM2010-U10	1	6	0,95	10	1,5	57	
H-NBM2010-U12	1	6	0,95	12	1,5	65	
H-NBM2010-U15	1	6	0,95	15	1,5	65	
H-NBM2010-U20	1	6	0,95	20	1,5	65	
H-NBM2015-U05	1,5	6	1,42	5	2	57	
H-NBM2015-U08	1,5	6	1,42	8	2	57	
H-NBM2015-U10	1,5	6	1,42	10	2	57	
H-NBM2015-U12	1,5	6	1,42	12	2	65	
H-NBM2015-U15	1,5	6	1,42	15	2	65	
H-NBM2015-U20	1,5	6	1,42	20	2	65	
H-NBM2020-U06	2	6	1,92	6	3	57	
H-NBM2020-U08	2	6	1,92	8	3	57	
H-NBM2020-U10	2	6	1,92	10	3	57	

Ref.	Dimensiones (mm)						Precio €
2 Flutes (Z2)	Dc	d	U/C	U	Lc	L	
H-NBM2020-U12	2	6	1,92	12	3	57	
H-NBM2020-U14	2	6	1,92	14	3	57	
H-NBM2020-U16	2	6	1,92	16	3	60	
H-NBM2020-U20	2	6	1,92	20	3	60	
H-NBM2020-U25	2	6	1,92	25	3	60	
H-NBM2020-U30	2	6	1,92	30	3	75	
H-NBM2020-U35	2	6	1,92	35	2	75	
H-NBM2020-U40	2	6	1,92	40	3	80	
H-NBM2020-U50	2	6	1,92	50	3	100	
H-NBM2025-U20	2,5	6	2,4	20	4	60	
H-NBM2025-U30	2,5	6	2,4	30	4	80	
H-NBM2025-U40	2,5	6	2,4	40	4	80	
H-NBM2030-U09	3	6	2,9	9	5	60	
H-NBM2030-U12	3	6	2,9	12	5	60	
H-NBM2030-U15	3	6	2,9	15	5	60	
H-NBM2030-U20	3	6	2,9	20	5	60	
H-NBM2030-U25	3	6	2,9	25	5	65	
H-NBM2030-U30	3	6	2,9	30	5	80	
H-NBM2030-U35	3	6	2,9	35	5	80	
H-NBM2030-U40	3	6	2,9	40	5	80	
H-NBM2030-U50	3	6	2,9	50	5	100	
H-NBM2040-U10	4	6	3,9	10	6	57	
H-NBM2040-U12	4	6	3,9	12	6	60	
H-NBM2040-U16	4	6	3,9	16	6	60	
H-NBM2040-U20	4	6	3,9	20	6	60	
H-NBM2040-U25	4	6	3,9	25	6	65	
H-NBM2040-U30	4	6	3,9	30	6	80	
H-NBM2040-U35	4	6	3,9	35	6	80	
H-NBM2040-U40	4	6	3,9	40	6	80	
H-NBM2040-U50	4	6	3,9	50	6	100	
H-NBM2050-U20	5	6	4,8	20	7	60	
H-NBM2050-U30	5	6	4,8	30	7	80	
H-NBM2050-U40	5	6	4,8	40	7	80	
H-NBM2050-U50	5	6	4,8	50	7	100	

I Z2 FRESAS ESFERICAS CÓNICAS

EN Z2 BALL NOSE END MILL | CONICAL FORM - PENCIL FORM

FR Z2 FRAISE CYLINDRIQUE HÉMISPHERIQUE

DE Z2 KUGELFRÄSER

ES Acero, Acero Inoxidable, Fundición Gris, Cobre, Titanio y Aceros hasta 62 HRC.

EN Steel, Stainless Steel, Cast Iron, Cooper, Titanium and Hardened Steels up to 62 HRC.

FR Acier, Acier Inoxydable, Fonte Grise, Cuivre, Titane et Acier Jusq'ua 62 HRC.

DE Stahl, Rostfreier Stahl, Gubeisen, Kupfer, Titan, Gehärteter Stahl 62 HRC.



ALTIM NANO



CONICAL FORM - PENCIL FORM

Ref.	Dimensiones (mm)					Precio €
	Dc	d	C	Lc	L	
2 Flutes (Z2)						
H-CBM2010-20	1	6	20	1,5	60	
H-CBM2010-30	1	6	30	1,5	65	
H-CBM2010L-40	1	6	40	1,5	80	
H-CBM2010L-50	1	6	50	1,5	100	
H-CBM2010XL-60	1	6	60	1,5	108	
H-CBM2010XL-70	1	6	70	1,5	108	
H-CBM2015-20	1,5	6	20	2	60	
H-CBM2015-30	1,5	6	30	2	65	
H-CBM2015L-40	1,5	6	40	2	80	
H-CBM2015XL-50	1,5	6	50	2	100	
H-CBM2015XL-60	1,5	6	60	2	108	
H-CBM2015XL-70	1,5	6	70	2	108	
H-CBM2020-20	2	6	20	3	60	
H-CBM2020-25	2	6	25	6	60	
H-CBM2020-30	2	6	30	6	65	
H-CBM2020L-40	2	6	40	3	80	

I Z2 FRESAS ESFERICAS CÓNICAS CON FORMA DE LAPIZ

EN Z2 BALL NOSE END MILL | CONICAL FORM - PENCIL FORM

FR Z2 FRAISE CYLINDRIQUE HÉMISPHERIQUE

DE Z2 KUGELFRÄSER



Ref.	Dimensiones (mm)					Precio €
	2 Flutes (Z2)	Dc	d	C	Lc	
H-CBM2020XL-50	2	6	50	3	100	
H-CBM2020XL-60	2	6	60	3	108	
H-CBM2020XL-70	2	6	70	3	108	
H-CBM2030-20	3	6	20	7	60	
H-CBM2030-30	3	6	30	7	65	
H-CBM2030L-40	3	6	40	5	80	
H-CBM2030L-50	3	6	50	5	100	
H-CBM2030XL-60	3	6	60	5	108	
H-CBM2030XL-70	3	6	70	5	108	
H-CBM2040-20	4	6	20	8	60	
H-CBM2040-25	4	6	25	8	60	
H-CBM2040-30	4	6	30	8	65	
H-CBM2040L-40	4	6	40	6	80	
H-CBM2040L-50	4	6	50	6	100	
H-CBM2040XL-60	4	6	60	6	108	
H-CBM2040XL-70	4	6	70	6	108	
H-CBM2040-50	4	8	50	8	100	
H-CBM2050-25	5	6	25	7	60	
H-CBM2050L-50	5	6	50	7	100	
H-CBM2050-41	5	8	41	12	90	
H-CBM2050-60	5	8	60	12	90	
H-CBM2060-33	6	8	33	14	90	
H-CBM2060L-50	6	8	50	9	100	
H-CBM2060-50	6	10	50	12	100	
H-CBM2080-40	8	10	40	12	100	
H-CBM2100-50	10	12	50	20	100	
H-CBM2100-60	10	16	60	20	150	
H-CBM2120-60	12	16	60	20	150	

I Z2 FRESAS ESFERICAS CÓNICA 1°

1° DE SALIDA / RADIO

EN Z2 BALL NOSE END MILL 1°

FR Z2 FRAISE CYLINDRIQUE HÉMISPHERIQUE 1°

DE Z2 KUGELFRÄSER 1°

ES Acero, Acero Inoxidable, Fundición Gris, Cobre, Titanio y Aceros hasta 62 HRC.

EN Steel, Stainless Steel, Cast Iron, Cooper, Titanium and Hardened Steels up to 62 HRC.

FR Acier, Acier Inoxydable, Fonte Grise, Cuivre, Titane et Acier Jusq'ua 62 HRC.

DE Stahl, Rostfreier Stahl, Gubeisen, Kupfer, Titan, Gehärteter Stahl 62 HRC.



ALTIN NANO



CONICAL FORM - TAPER 1°

Ref.	Dimensiones (mm)					Precio €
2 Flutes (Z2)	Dc	d	C	Lc	L	
H-CBM2010-C20x1°	1	6	20	1,5	60	
H-CBM2010-C30x1°	1	6	30	1,5	65	
H-CBM2010L-C40x1°	1	6	40	1,5	80	
H-CBM2010XL-C50x1°	1	6	50	1,5	100	
H-CBM2010XL-C60x1°	1	6	60	1,5	108	
H-CBM2010XL-C70x1°	1	6	70	1,5	108	
H-CBM2015-C20x1°	1,5	6	20	2	60	
H-CBM2015-C30x1°	1,5	6	30	2	65	
H-CBM2015XL-C30x1°	1,5	6	30	2	108	
H-CBM2015L-C40x1°	1,5	6	40	2	80	
H-CBM2015L-C43x1°	1,5	6	43	2	108	
H-CBM2015XL-C50x1°	1,5	6	50	2	100	
H-CBM2015XL-C53x1°	1,5	6	53	2	108	
H-CBM2015XL-C63x1°	1,5	6	63	2	108	
H-CBM2015XL-C70x1°	1,5	6	70	2	108	

I Z2 FRESAS ESFERICAS CÓNICA 1°

1° DE SALIDA / RADIO



Ref.	Dimensiones (mm)					Precio €
2 Flutes (Z2)	Dc	d	C	Lc	L	
H-CBM2015XL-C85x1°	1,5	6	85	2	150	
H-CBM2020-C20x1°	2	6	20	3	60	
H-CBM2020-C30x1°	2	6	30	3	65	
H-CBM2020L-C30x1°	2	6	30	3	80	
H-CBM2020XL-C30x1°	2	6	30	3	108	
H-CBM2020L-C40x1°	2	6	40	3	80	
H-CBM2020XL-C43x1°	2	6	43	3	108	
H-CBM2020XL-C50x1°	2	6	50	3	100	
H-CBM2020XL-C53x1°	2	6	53	3	108	
H-CBM2020XL-C63x1°	2	6	63	3	108	
H-CBM2020XL-C70x1°	2	6	70	3	108	
H-CBM2020XL-C85x1°	2	6	85	3	150	
H-CBM2030-C20x1°	3	6	20	5	60	
H-CBM2030-C30x1°	3	6	30	5	65	
H-CBM2030XL-C35x1°	3	6	35	5	108	
H-CBM2030L-C40x1°	3	6	40	5	80	
H-CBM2030XL-C44x1°	3	6	44	5	108	
H-CBM2030XL-C50x1°	3	6	50	5	100	
H-CBM2030XL-C55x1°	3	6	55	5	108	
H-CBM2030XL-C65x1°	3	6	65	5	108	
H-CBM2030XL-C75x1°	3	6	75	5	108	
H-CBM2030XL-C85x1°	3	6	85	5	150	
H-CBM2040-C20x1°	4	6	20	6	60	
H-CBM2040-C30x1°	4	6	30	6	65	
H-CBM2040XL-C35x1°	4	6	35	6	108	
H-CBM2040L-C40x1°	4	6	40	6	80	
H-CBM2040XL-C45x1°	4	6	45	6	108	
H-CBM2040XL-C50x1°	4	6	50	6	100	
H-CBM2040XL-C55x1°	4	6	55	6	108	
H-CBM2040XL-C65x1°	4	6	65	6	108	
H-CBM2040XL-C70x1°	4	6	70	6	150	

I Z2 FRESAS ESFERICAS CÓNICA 1,5° SALIDA / RADIO / MANGO 6

EN Z2 BALL NOSE END MILL | CONICAL FORM | TAPER 1,5°
FR Z2 FRAISE CYLINDRIQUE HÉMISPHERIQUE
DE Z2 KUGELFRÄSER

ES Acero, Acero Inoxidable, Fundición Gris, Cobre, Titanio y Aceros hasta 62 HRC.

EN Steel, Stainless Steel, Cast Iron, Cooper, Titanium and Hardened Steels up to 62 HRC.

FR Acier, Acier Inoxydable, Fonte Grise, Cuivre, Titane et Acier Jusqu'à 62 HRC.

DE Stahl, Rostfreier Stahl, Gubeisen, Kupfer, Titan, Gehärteter Stahl 62 HRC.



ALTIN NANO



CONICA 1,5° SALIDA

Ref.	Dimensiones (mm)					Precio €
	Dc	d	C	Lc	L	
2 Flutes (Z2)						
H-CBM2010-C20x1,5°	1	6	20	1,5	60	
H-CBM2010-C30x1,5°	1	6	30	1,5	65	
H-CBM2010L-C40x1,5°	1	6	40	1,5	80	
H-CBM2010XL-C50x1,5°	1	6	50	1,5	100	
H-CBM2010XL-C60x1,5°	1	6	60	1,5	108	
H-CBM2010XL-C70x1,5°	1	6	70	1,5	108	
H-CBM2015-C20x1,5°	1,5	6	20	2	60	
H-CBM2015-C30x1,5°	1,5	6	30	2	65	
H-CBM2015XL-C30x1,5°	1,5	6	30	2	108	
H-CBM2015L-C40x1,5°	1,5	6	40	2	80	
H-CBM2015L-C43x1,5°	1,5	6	43	2	108	
H-CBM2015XL-C50x1,5°	1,5	6	50	2	100	
H-CBM2015XL-C53x1,5°	1,5	6	53	2	108	
H-CBM2015XL-C63x1,5°	1,5	6	63	2	108	
H-CBM2015XL-C70x1,5°	1,5	6	70	2	108	

I Z2 FRESAS ESFERICAS CÓNICA 1,5°

SALIDA / RADIO / MANGO 6

EN Z2 BALL NOSE END MILL | CONICAL FORM | TAPER 1,5°

FR Z2 FRAISE CYLINDRIQUE HÉMISPHERIQUE

DE Z2 KUGELFRÄSER



Ref.	Dimensiones (mm)					Precio €
	Dc	d	C	Lc	L	
2 Flutes (Z2)						
H-CBM2015XL-C85x1,5°	1,5	6	85	2	150	
H-CBM2020-C20x1,5°	2	6	20	3	60	
H-CBM2020-C30x1,5°	2	6	30	3	65	
H-CBM2020L-C30x1,5°	2	6	30	3	80	
H-CBM2020XL-C30x1,5°	2	6	30	3	108	
H-CBM2020L-C40x1,5°	2	6	40	3	80	
H-CBM2020XL-C40x1,5°	2	6	40	3	108	
H-CBM2020XL-C50x1,5°	2	6	50	3	100	
H-CBM2020XL-C53x1,5°	2	6	53	3	108	
H-CBM2020XL-C63x1,5°	2	6	63	3	108	
H-CBM2020XL-C70x1,5°	2	6	70	3	108	
H-CBM2020XL-C84x1,5°	2	6	84	3	150	
H-CBM2030-C20x1,5°	3	6	20	5	60	
H-CBM2030-C30x1,5°	3	6	30	5	65	
H-CBM2030XL-C35x1,5°	3	6	35	5	108	
H-CBM2030L-C40x1,5°	3	6	40	5	80	
H-CBM2030XL-C44x1,5°	3	6	44	5	108	
H-CBM2030XL-C50x1,5°	3	6	50	5	100	
H-CBM2030XL-C55x1,5°	3	6	55	5	108	
H-CBM2030XL-C65x1,5°	3	6	65	5	108	
H-CBM2030XLL-C65x1,5°	3	6	65	5	150	
H-CBM2040-C20x1,5°	4	6	20	6	60	
H-CBM2040-C30x1,5°	4	6	30	6	65	
H-CBM2040-C35x1,5°	4	6	35	6	108	
H-CBM2040L-C40x1,5°	4	6	40	6	80	
H-CBM2040XL-C45x1,5°	4	6	45	6	108	

I Z2 ARRAL-TOP: FRESAS ESFERICAS CILÍNDRICAS

- EN** Z2 ARRAL-TOP: BALL NOSE END MILL
FR Z2 ARRAL-TOP: FRAISE CYLINDRIQUE HÉMISPHERIQUE
DE Z2 ARRAL-TOP: KUGELFRÄSER

- ES** Acero, Acero Inoxidable, Fundición Gris, Cobre, Titanio y Aceros hasta 62 HRC.
EN Steel, Stainless Steel, Cast Iron, Cooper, Titanium and Hardened Steels up to 62 HRC.
FR Acier, Acier Inoxydable, Fonte Grise, Cuivre, Titane et Acier Jusqu'à 62 HRC.
DE Stahl, Rostfreier Stahl, Gubeisen, Kupfer, Titan, Gehärteter Stahl 62 HRC.



ALCrN



Ref.	Dimensiones (mm)				Precio €
	Dc	d	Lc	L	
2 Flutes (Z2)					
AT-SBM2060	6	6	12	50	
AT-SBM2060L	6	6	8	80	
AT-SBM2060LL	6	6	15	100	
AT-SBM2080	8	8	15	60	
AT-SBM2080L	8	8	12	100	
AT-SBM2100	10	10	20	72	
AT-SBM2100L	10	10	15	100	
AT-SBM2120	12	12	20	75	
AT-SBM2120L	12	12	15	100	

Z2 ARRAL-TOP: FRESAS ESFERICAS CÓNICAS 1° CON 1° DE SALIDA AL RADIO

- EN** Z2 ARRAL-TOP: BALL NOSE END MILL | TAPER 1°
FR Z2 ARRAL-TOP: FRAISE CYLINDRIQUE HÉMISPHERIQUE
DE Z2 ARRAL-TOP: KUGELFRÄSER

- ES** Acero, Acero Inoxidable, Fundición Gris, Cobre, Titanio y Aceros hasta 62 HRC.
EN Steel, Stainless Steel, Cast Iron, Cooper, Titanium and Hardened Steels up to 62 HRC.
FR Acier, Acier Inoxydable, Fonte Grise, Cuivre, Titane et Acier Jusq'ua 62 HRC.
DE Stahl, Rostfreier Stahl, Gubeisen, Kupfer, Titan, Gehärteter Stahl 62 HRC.



ALCrN



CONICAL FORM - TAPER 1°

Ref.	Dimensiones (mm)					Precio €
	Dc	d	C	Lc	L	
2 Flutes (Z2)						
AT-CBM2060XL-C35x1°	6	8	35	9	108	
AT-CBM2060XL-C48x1°	6	8	48	9	108	
AT-CBM2060XL-C55x1°	6	8	55	9	108	
AT-CBM2060XL-C70x1°	6	8	70	9	108	
AT-CBM2060XL-C73x1°	6	8	73	9	150	
AT-CBM2080XL-C48x1°	8	10	48	10	108	
AT-CBM2080XL-C55x1°	8	10	55	10	108	
AT-CBM2080XL-C70x1°	8	10	70	10	108	
AT-CBM2080XXL-C70x1°	8	10	70	10	150	

Z2 ARRAL-TOP: FRESAS ESFERICAS CÓNICAS 1,5° CON 1,5° DE SALIDA AL RADIO

- EN** Z2 ARRAL-TOP: BALL NOSE END MILL | TAPER 1,5°
FR Z2 ARRAL-TOP: FRAISE CYLINDRIQUE HÉMISPHERIQUE
DE Z2 ARRAL-TOP: KUGELFRÄSER

- ES** Acero, Acero Inoxidable, Fundición Gris, Cobre, Titanio y Aceros hasta 62 HRC.
EN Steel, Stainless Steel, Cast Iron, Cooper, Titanium and Hardened Steels up to 62 HRC.
FR Acier, Acier Inoxydable, Fonte Grise, Cuivre, Titane et Acier Jusqu'à 62 HRC.
DE Stahl, Rostfreier Stahl, Gubeisen, Kupfer, Titan, Gehärteter Stahl 62 HRC.



ALCrN



CONICAL FORM - TAPER 1,5°

Ref.	Dimensiones (mm)					Precio €
	Dc	d	C	Lc	L	
2 Flutes (Z2)						
AT-CBM2060XL-C35x1,5°	6	8	35	9	108	
AT-CBM2060XL-C48x1,5°	6	8	48	9	108	
AT-CBM2060XXL-C48x1,5°	6	8	48	9	150	
AT-CBM2080XL-C48x1,5°	8	10	48	10	108	
AT-CBM2080XXL-C48x1,5°	8	10	48	10	150	

Z2 FRESAS ESFÉRICAS MATERIAL DURO SerieNormal

MECANIZADO DURO 70HRC

EN Z2 BALL NOSE END MILL | HARD CUTTING 70HRC | Normal Series

FR Z2 FRAISE CYLINDRIQUE HÉMISPHERIQUE | 70HRC | Normale

DE Z2 KUGELFRÄSER | 70HRC | Normale

- ES** Fundición Gris y Aceros hasta 70 HRC.
- EN** Cast Iron, Cooper and Hardened Steels up to 70 HRC.
- FR** Fonte Grise, Cuivre et Acier Jusq'ua 70 HRC.
- DE** Gubeisen und Gehärteter Stahl 70 HRC.



ALTIN NANO



SERIE NORMAL

Ref.	Dimensiones (mm)							Precio €
	Dc	d	Uc	C	U	Lc	L	
2 Flutes (Z2)								
H-HBM2020	2	6	-	20	-	3	60	
H-HBM2030	3	6	-	20	-	5	60	
H-HBM2040	4	6	-	20	-	6	60	
H-HBM2050	5	6	4,8	-	20	10	60	
H-HBM2060	6	6	5,8	-	20	12	60	
H-HBM2080	8	8	7,8	-	20	12	80	
H-HBM2100	10	10	9,8	-	22	10	75	
H-HBM2120	12	12	11,8	-	24	12	75	
H-HBM2160	16	16	15,8	-	40	20	92	

Z2 FRESAS ESFERICAS MATERIAL DURO Serie Larga MECANIZADO DURO 70HRC

EN Z2 BALL NOSE END MILL | HARD CUTTING 70HRC | Long Series

FR Z2 FRAISE CYLINDRIQUE HÉMISPHERIQUE | HARD CUTTING 70HRC | Longue

DE Z2 KUGELFRÄSER | HARD CUTTING 70HRC | Lange

- ES Fundición Gris y Aceros hasta 70 HRC.
- EN Cast Iron, Cooper and Hardened Steels up to 70 HRC.
- FR Fonte Grise, Cuivre et Acier Jusqu'à 70 HRC.
- DE Gubeisen und Gehärteter Stahl 70 HRC.

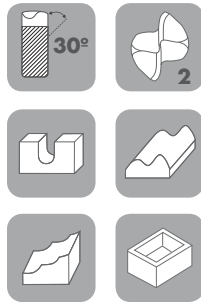

ALTiN NANO

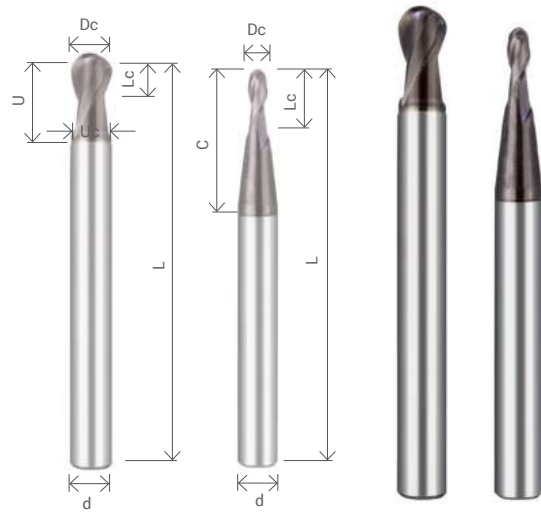

SERIE LARGA

Ref.	Dimensiones (mm)							Precio €
	Dc	d	Uc	C	U	Lc	L	
2 Flutes (Z2)								
H-HBM2020L	2	6	-	40	-	3	80	
H-HBM2030L	3	6	-	40	-	5	80	
H-HBM2040L	4	6	-	40	-	6	80	
H-HBM2050L	5	6	4,8	-	20	10	80	
H-HBM2060L	6	6	5,8	-	20	12	80	
H-HBM2080L	8	8	7,8	-	20	12	100	
H-HBM2100L	10	10	9,8	-	22	10	100	
H-HBM2120L	12	12	11,8	-	24	12	100	
H-HBM2160L	16	16	15,8	-	40	20	150	

I Z2 MICRO FRESAS ESFERICAS

SIN CUELLO / MANGO 4

EN Z2 BALL NOSE MICRO END MILL | WITHOUT NECK | Normal Series

FR Z2 MICROFRAISE CYLINDRIQUE HÉMISPHERIQUE | Normale

DE Z2 MIKROKUGELFRÄSER | Normale

ES Acero, Acero Inoxidable, Fundición Gris, Cobre, Titanio y Aceros hasta 62 HRC.

EN Steel, Stainless Steel, Cast Iron, Cooper, Titanium and Hardened Steels up to 62 HRC.

FR Acier, Acier Inoxydable, Fonte Grise, Cuivre, Titane et Acier Jusq'ua 62 HRC.

DE Stahl, Rostfreier Stahl, Gubeisen, Kupfer, Titan, Gehärteter Stahl 62 HRC.



ALTIN NANO



SERIE NORMAL

Ref.	Dimensiones (mm)				Precio €
	Dc	d	Lc	L	
2 Flutes (Z2)					
M-SBM2002	0,2	4	0,4	50	
M-SBM2003	0,3	4	0,6	50	
M-SBM2004	0,4	4	0,8	50	
M-SBM2005	0,5	4	1	50	
M-SBM2006	0,6	4	1,2	50	
M-SBM2007	0,7	4	1,4	50	
M-SBM2008	0,8	4	1,6	50	
M-SBM2009	0,9	4	1,8	50	

I Z2 MICRO FRESAS ESFERICAS CUELLO REBAJADO

- EN** Z2 BALL NOSE MICRO END MILL | WITH NECK
FR Z2 MICROFRAISE CYLINDRIQUE HÉMISPHERIQUE
DE Z2 MIKROKUGELFRÄSER

- ES** Acero, Acero Inoxidable, Fundición Gris, Cobre, Titanio y Aceros hasta 62 HRC.
EN Steel, Stainless Steel, Cast Iron, Cooper, Titanium and Hardened Steels up to 62 HRC.
FR Acier, Acier Inoxydable, Fonte Grise, Cuivre, Titane et Acier Jusqu'à 62 HRC.
DE Stahl, Rostfreier Stahl, Gubeisen, Kupfer, Titan, Gehärteter Stahl 62 HRC.



ALTiN NANO

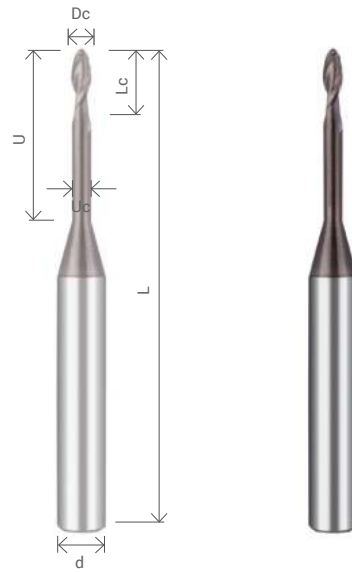

SERIE LARGA

Ref.	Dimensiones (mm)						Precio €
	Dc	d	Uc	U	Lc	L	
2 Flutes (Z2)							
M-SBM2005-04	0,5	4	0,48	4	0,7	50	
M-SBM2005-06	0,5	4	0,48	6	0,7	50	
M-SBM2006-04	0,6	4	0,57	4	0,9	50	
M-SBM2006-06	0,6	4	0,57	6	0,9	50	
M-SBM2006-08	0,6	4	0,57	8	0,9	50	
M-SBM2008-06	0,8	4	0,76	6	1,2	50	
M-SBM2008-08	0,8	4	0,76	8	1,2	50	
M-SBM2008-10	0,8	4	0,76	10	1,2	50	
M-SBM2012-06	1,2	4	1,15	6	1,8	50	
M-SBM2012-08	1,2	4	1,15	8	1,8	50	
M-SBM2012-10	1,2	4	1,15	10	1,8	50	

04

FRESAS tóricas

CORNER RADIUS END MILL
FRAISE TORIQUE
TORUSFRÄSER END MILL

I Z2 FRESA TÓRICA Serie Normal

- EN** Z2 CORNER RADIUS END MILL | Normal Series
FR Z2 FRAISE TORIQUE | Normale
DE Z2 TORUSFRÄSER | Normale

ES Acero, Acero Inoxidable, Fundición Gris, Cobre, Titanio y Aceros hasta 62 HRC.

EN Steel, Stainless Steel, Cast Iron, Cooper, Titanium and Hardened Steels up to 62 HRC.

FR Acier, Acier Inoxydable, Fonte Grise, Cuivre, Titane et Acier Jusq'ua 62 HRC.

DE Stahl, Rostfreier Stahl, Gubeisen, Kupfer, Titan, Gehärteter Stahl 62 HRC.

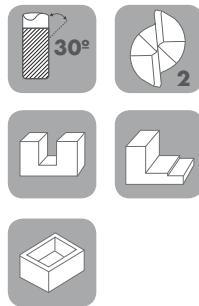

ALTiN NANO

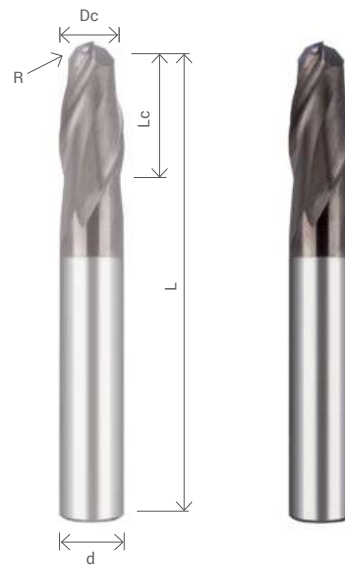

SERIE NORMAL

Ref.	Dimensiones (mm)					Precio €
	Dc	d	R	Lc	L	
2 Flutes (Z2)						
H-SEM2020S-r0,2	2	6	0,2	6	50	
H-SEM2020S-r0,5	2	6	0,5	6	50	
H-SEM2030S-r0,2	3	6	0,2	8	50	
H-SEM2030S-r0,5	3	6	0,5	8	50	
H-SEM2040S-r0,2	4	6	0,2	11	50	
H-SEM2040S-r0,5	4	6	0,5	11	50	
H-SEM2040S-r1,0	4	6	1	11	50	
H-SEM2050S-r0,2	5	6	0,2	12	50	
H-SEM2050S-r0,5	5	6	0,5	12	50	
H-SEM2050S-r1,0	5	6	1	12	50	
H-SEM2060S-r0,2	6	6	0,2	12	50	
H-SEM2060S-r0,5	6	6	0,5	13	50	
H-SEM2060S-r1,0	6	6	1	13	50	
H-SEM2060S-r1,5	6	6	1,5	13	50	
H-SEM2060S-r2,0	6	6	2	13	50	

I Z2 FRESA TÓRICA Serie Normal

EN Z2 CORNER RADIUS END MILL | Normal Series

FR Z2 FRAISE TORIQUE | Normale

DE Z2 TORUSFRÄSER | Normale



Ref.	Dimensiones (mm)					Precio €
	Dc	d	R	Lc	L	
2 Flutes (Z2)						
H-SEM2080S-r0,2	8	8	0,2	15	60	
H-SEM2080S-r0,5	8	8	0,5	15	60	
H-SEM2080S-r1,0	8	8	1	15	60	
H-SEM2080S-r1,5	8	8	1,5	15	60	
H-SEM2080S-r2,0	8	8	2	15	60	
H-SEM2100S-r0,5	10	10	0,5	20	72	
H-SEM2100S-r1,0	10	10	1	20	72	
H-SEM2100S-r1,5	10	10	1,5	20	72	
H-SEM2100S-r2,0	10	10	2	20	72	
H-SEM2100S-r3,0	10	10	3	20	72	
H-SEM2120S-r0,5	12	12	0,5	24	75	
H-SEM2120S-r1,0	12	12	1	24	75	
H-SEM2120S-r1,5	12	12	1,5	24	75	
H-SEM2120S-r2,0	12	12	2	24	75	
H-SEM2120S-r3,0	12	12	3	24	75	
H-SEM2160S-r0,5	16	16	0,5	30	92	
H-SEM2160S-r1,0	16	16	1	30	92	
H-SEM2160S-r2,0	16	16	2	30	92	
H-SEM2160S-r3,0	16	16	3	30	92	
H-SEM2160S-r4,0	16	16	4	30	92	

I Z4 FRESA TÓRICA Serie Normal

- EN** Z4 CORNER RADIUS END MIL | Normal Series
FR Z4 FRAISE TORIQUE | Normale
DE Z4 TORUSFRÄSER | Normale

ES Acero, Acero Inoxidable, Fundición Gris, Cobre, Titanio y Aceros hasta 62 HRC.

EN Steel, Stainless Steel, Cast Iron, Cooper, Titanium and Hardened Steels up to 62 HRC.

FR Acier, Acier Inoxydable, Fonte Grise, Cuivre, Titane et Acier Jusq'ua 62 HRC.

DE Stahl, Rostfreier Stahl, Gubeisen, Kupfer, Titan, Gehärteter Stahl 62 HRC.

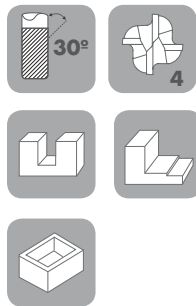

ALTiN NANO



SERIE NORMAL

Ref.	Dimensiones (mm)					Precio €
	Dc	d	R	Lc	L	
4 Flutes (Z4)						
H-SEM4020S-r0,2	2	6	0,2	6	50	
H-SEM4020S-r0,5	2	6	0,5	6	50	
H-SEM4030S-r0,2	3	6	0,2	8	50	
H-SEM4030S-r0,5	3	6	0,5	8	50	
H-SEM4040S-r0,2	4	6	0,2	11	50	
H-SEM4040S-r0,5	4	6	0,5	11	50	
H-SEM4040S-r1,0	4	6	1	11	50	
H-SEM4050S-r0,2	5	6	0,2	12	50	
H-SEM4050S-r0,5	5	6	0,5	12	50	
H-SEM4050S-r1,0	5	6	1	12	50	
H-SEM4060S-r0,2	6	6	0,2	12	50	
H-SEM4060S-r0,5	6	6	0,5	13	50	
H-SEM4060S-r1,0	6	6	1	13	50	
H-SEM4060S-r1,5	6	6	1,5	13	50	
H-SEM4060S-r2,0	6	6	2	13	50	
H-SEM4080S-r0,2	8	8	0,2	15	60	

I Z4 FRESA TÓRICA Serie Normal

EN Z4 CORNER RADIUS END MILL | Normal Series

FR Z4 FRAISE TORIQUE | Normale

DE Z4 TORUSFRÄSER | Normale



Ref.	Dimensiones (mm)					Precio €
	Dc	d	R	Lc	L	
4 Flutes (Z4)						
H-SEM4080S-r0,5	8	8	0,5	15	60	
H-SEM4080S-r1,0	8	8	1	15	60	
H-SEM4080S-r1,5	8	8	1,5	15	60	
H-SEM4080S-r2,0	8	8	2	15	60	
H-SEM4100S-r0,5	10	10	0,5	20	72	
H-SEM4100S-r1,0	10	10	1	20	72	
H-SEM4100S-r1,5	10	10	1,5	20	72	
H-SEM4100S-r2,0	10	10	2	20	72	
H-SEM4100S-r3,0	10	10	3	20	72	
H-SEM4120S-r0,5	12	12	0,5	24	75	
H-SEM4120S-r1,0	12	12	1	24	75	
H-SEM4120S-r1,5	12	12	1,5	24	75	
H-SEM4120S-r2,0	12	12	2	24	75	
H-SEM4120S-r3,0	12	12	3	24	75	
H-SEM4160S-r0,5	16	16	0,5	30	92	
H-SEM4160S-r1,0	16	16	1	30	92	
H-SEM4160S-r2,0	16	16	2	30	92	
H-SEM4160S-r3,0	16	16	3	30	92	
H-SEM4160S-r4,0	16	16	4	30	92	

I Z2 FRESA TÓRICA Corte Normal

EN Z2 CORNER RADIUS END MILL | Normal Cutting

FR Z2 FRAISE TORIQUE | Normal Cutting

DE Z2 TORUSFRÄSER | Normal Cutting

ES Acero, Acero Inoxidable, Fundición Gris, Cobre, Titanio y Aceros hasta 62 HRC.

EN Steel, Stainless Steel, Cast Iron, Cooper, Titanium and Hardened Steels up to 62 HRC.

FR Acier, Acier Inoxydable, Fonte Grise, Cuivre, Titane et Acier Jusqu'à 62 HRC.

DE Stahl, Rostfreier Stahl, Gubeisen, Kupfer, Titan, Gehärteter Stahl 62 HRC.

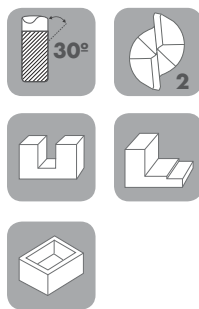

ALTIM NANO



Ref.	Dimensiones (mm)					Precio €
2 Flutes (Z2)	Dc	d	R	Lc	L	
H-SEM2060X-r0,2	6	6	0,2	13	80	
H-SEM2060X-r0,5	6	6	0,5	13	80	
H-SEM2060X-r1,0	6	6	1	13	80	
H-SEM2060X-r1,5	6	6	1,5	13	80	
H-SEM2060X-r2,0	6	6	2	13	80	
H-SEM2080X-r0,5	8	8	0,5	19	90	
H-SEM2080X-r1,0	8	8	1	19	90	
H-SEM2080X-r1,5	8	8	1,5	19	90	
H-SEM2080X-r2,0	8	8	2	19	90	
H-SEM2100X-r0,5	10	10	0,5	22	100	
H-SEM2100X-r1,0	10	10	1	22	100	
H-SEM2100X-r1,5	10	10	1,5	22	100	
H-SEM2100X-r2,0	10	10	2	22	100	
H-SEM2100X-r3,0	10	10	3	22	100	
H-SEM2120X-r0,5	12	12	0,5	26	100	
H-SEM2120X-r1,0	12	12	1	26	100	
H-SEM2120X-r1,5	12	12	1,5	26	100	
H-SEM2120X-r2,0	12	12	2	26	100	
H-SEM2120X-r3,0	12	12	3	26	100	

Z4 FRESA TÓRICA Corte Normal

EN Z4 CORNER RADIUS END MILL | Normal Cutting

FR Z4 FRAISE TORIQUE | Normal Cutting

DE Z4 TORUSFRÄSER | Normal Cutting

ES Acero, Acero Inoxidable, Fundición Gris, Cobre, Titanio y Aceros hasta 62 HRC.

EN Steel, Stainless Steel, Cast Iron, Cooper, Titanium and Hardened Steels up to 62 HRC.

FR Acier, Acier Inoxydable, Fonte Grise, Cuivre, Titane et Acier Jusq'ua 62 HRC.

DE Stahl, Rostfreier Stahl, Gubeisen, Kupfer, Titan, Gehärteter Stahl 62 HRC.

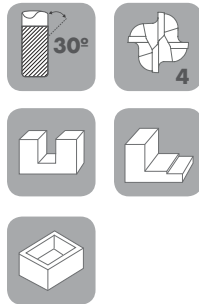

ALTIN NANO

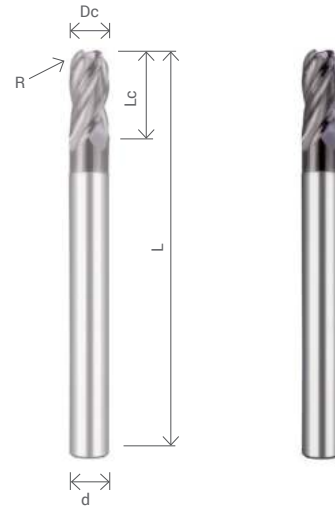

Ref.	Dimensiones (mm)					Precio €
	Dc	d	R	Lc	L	
4 Flutes (Z4)						
H-SEM4060X-r0,2	6	6	0,2	13	80	
H-SEM4060X-r0,5	6	6	0,5	13	80	
H-SEM4060X-r1,0	6	6	1	13	80	
H-SEM4060X-r1,5	6	6	1,5	13	80	
H-SEM4060X-r2,0	6	6	2	13	80	
H-SEM4080X-r0,5	8	8	0,5	19	90	
H-SEM4080X-r1,0	8	8	1	19	90	
H-SEM4080X-r1,5	8	8	1,5	19	90	
H-SEM4080X-r2,0	8	8	2	19	90	
H-SEM4100X-r0,5	10	10	0,5	22	100	
H-SEM4100X-r1,0	10	10	1	22	100	
H-SEM4100X-r1,5	10	10	1,5	22	100	
H-SEM4100X-r2,0	10	10	2	22	100	
H-SEM4100X-r3,0	10	10	3	22	100	
H-SEM4120X-r0,5	12	12	0,5	26	100	
H-SEM4120X-r1,0	12	12	1	26	100	
H-SEM4120X-r1,5	12	12	1,5	26	100	
H-SEM4120X-r2,0	12	12	2	26	100	
H-SEM4120X-r3,0	12	12	3	26	100	

I Z2 FRESA TÓRICA CORTE Corte Largo

EN Z2 CORNER RADIUS END MILL | Long Cutting

FR Z2 FRAISE TORIQUE

DE Z2 TORUSFRÄSER

ES Acero, Acero Inoxidable, Fundición Gris, Cobre, Titanio y Aceros hasta 62 HRC.

EN Steel, Stainless Steel, Cast Iron, Cooper, Titanium and Hardened Steels up to 62 HRC.

FR Acier, Acier Inoxydable, Fonte Grise, Cuivre, Titane et Acier Jusq'ua 62 HRC.

DE Stahl, Rostfreier Stahl, Gubeisen, Kupfer, Titan, Gehärteter Stahl 62 HRC.

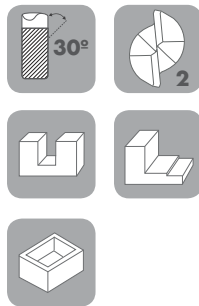

ALTIM NANO



LONG CUTTING

Ref.	Dimensiones (mm)					Precio €
	Dc	d	R	Lc	L	
2 Flutes (Z2)						
H-SEM2020L-R0,2	2	6	0,2	10	80	
H-SEM2020L-R0,5	2	6	0,5	10	80	
H-SEM2030L-R0,2	3	6	0,2	15	80	
H-SEM2030L-R0,5	3	6	0,5	15	80	
H-SEM2040L-R0,2	4	6	0,2	20	80	
H-SEM2040L-R0,5	4	6	0,5	20	80	
H-SEM4040L-R1,0	4	6	1	20	80	
H-SEM2050L-R0,2	5	6	0,2	25	80	
H-SEM2050L-R0,5	5	6	0,5	25	80	
H-SEM2050L-R1,0	5	6	1	25	80	
H-SEM2060L-r0,2	6	6	0,2	25	80	
H-SEM2060L-r0,5	6	6	0,5	25	80	
H-SEM2060L-r1,0	6	6	1	25	80	
H-SEM2060L-r2,0	6	6	2	25	80	

I Z2 FRESA TÓRICA CORTE Corte Largo

EN Z2 CORNER RADIUS END MILL | Long Cutting

FR Z2 FRAISE TORIQUE

DE Z2 TORUSFRÄSER



Ref.	Dimensiones (mm)					Precio €
	Dc	d	R	Lc	L	
2 Flutes (Z2)						
H-SEM2080L-r0,5	8	8	0,5	35	90	
H-SEM2080L-r1,0	8	8	1	35	90	
H-SEM2080L-r2,0	8	8	2	35	90	
H-SEM2100L-r0,5	10	10	0,5	45	100	
H-SEM2100L-r1,0	10	10	1	45	100	
H-SEM2100L-r2,0	10	10	2	45	100	
H-SEM2100L-r3,0	10	10	3	45	100	
H-SEM2120L-r0,5	12	12	0,5	50	100	
H-SEM2120L-r1,0	12	12	1	50	100	
H-SEM2120L-r2,0	12	12	2	50	100	
H-SEM2120L-r3,0	12	12	3	50	100	

Z4 FRESA TÓRICA CORTE Corte Largo

EN Z4 CORNER RADIUS END MILL | Long Cutting

FR Z4 FRAISE TORIQUE

DE Z4 TORUSFRÄSER

ES Acero, Acero Inoxidable, Fundición Gris, Cobre, Titanio y Aceros hasta 62 HRC.

EN Steel, Stainless Steel, Cast Iron, Cooper, Titanium and Hardened Steels up to 62 HRC.

FR Acier, Acier Inoxydable, Fonte Grise, Cuivre, Titane et Acier Jusq'ua 62 HRC.

DE Stahl, Rostfreier Stahl, Gubeisen, Kupfer, Titan, Gehärteter Stahl 62 HRC.

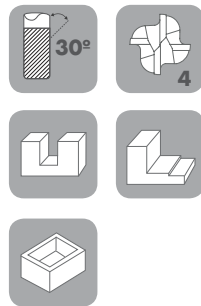

ALTIM NANO



LONG CUTTING

Ref.	Dimensiones (mm)					Precio €
	Dc	d	R	Lc	L	
4 Flutes (Z4)						
H-SEM4020L-R0,5	2	6	0,5	10	80	
H-SEM4020L-R0,2	2	6	0,2	10	80	
H-SEM4030L-R0,5	3	6	0,5	15	80	
H-SEM4040L-R0,2	4	6	0,2	20	80	
H-SEM4040L-R0,5	4	6	0,5	20	80	
H-SEM4040L-R1,0	4	6	1	20	80	
H-SEM4050L-R0,2	5	6	0,2	25	80	
H-SEM4050L-R0,5	5	6	0,5	25	80	
H-SEM4050L-R1,0	5	6	1	25	80	
H-SEM4060L-r0,2	6	6	0,2	25	80	
H-SEM4060L-r0,5	6	6	0,5	25	80	
H-SEM4060L-r1,0	6	6	1	25	80	
H-SEM4060L-r2,0	6	6	2	25	80	
H-SEM4080L-r0,5	8	8	0,5	35	90	
H-SEM4080L-r1,0	8	8	1	35	90	
H-SEM4080L-r2,0	8	8	2	35	90	

I Z4 FRESA TÓRICA CORTE Corte Largo

EN Z4 CORNER RADIUS END MILL | Long Cutting

FR Z4 FRAISE TORIQUE

DE Z4 TORUSFRÄSER



Ref.	Dimensiones (mm)					Precio €
	Dc	d	R	Lc	L	
2 Flutes (Z2)						
H-SEM4100L-r0,5	10	10	0,5	45	100	
H-SEM4100L-r1,0	10	10	1	45	100	
H-SEM4100L-r2,0	10	10	2	45	100	
H-SEM4100L-r3,0	10	10	3	45	100	
H-SEM4120L-r0,5	12	12	0,5	50	100	
H-SEM4120L-r1,0	12	12	1	50	100	
H-SEM4120L-r2,0	12	12	2	50	100	
H-SEM4120L-r3,0	12	12	3	50	100	

I Z2 FRESA TÓRICA EXTRALARGA

- EN** Z2 CORNER RADIUS END MILL | Extralong Series
FR Z2 FRAISE TORIQUE | Extra Longue
DE Z2 TORUSFRÄSER | Extra Lange

ES Acero, Acero Inoxidable, Fundición Gris, Cobre, Titanio y Aceros hasta 62 HRC.

EN Steel, Stainless Steel, Cast Iron, Cooper, Titanium and Hardened Steels up to 62 HRC.

FR Acier, Acier Inoxydable, Fonte Grise, Cuivre, Titane et Acier Jusq'ua 62 HRC.

DE Stahl, Rostfreier Stahl, Gubeisen, Kupfer, Titan, Gehärteter Stahl 62 HRC.

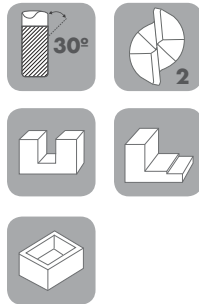

ALTIM NANO



SERIE LARGA

Ref.	Dimensiones (mm)					Precio €
2 Flutes (Z2)	Dc	d	R	Lc	L	
H-SEM2060XL-r0,5	6	6	0,5	13	150	
H-SEM2060XL-r1,0	6	6	1	13	150	
H-SEM2060XL-r1,5	6	6	1,5	13	150	
H-SEM2060XL-r2,0	6	6	2	13	150	
H-SEM2080XL-r0,5	8	8	0,5	19	150	
H-SEM2080XL-r1,0	8	8	1	19	150	
H-SEM2080XL-r1,5	8	8	1,5	19	150	
H-SEM2080XL-r2,0	8	8	2	19	150	
H-SEM2100XL-r0,5	10	10	0,5	22	150	
H-SEM2100XL-r1,0	10	10	1	22	150	
H-SEM2100XL-r2,0	10	10	2	22	150	
H-SEM2100XL-r3,0	10	10	3	22	150	
H-SEM2120XL-r0,5	12	12	0,5	26	150	
H-SEM2120XL-r1,0	12	12	1	26	150	
H-SEM2120XL-r2,0	12	12	2	26	150	
H-SEM2120XL-r3,0	12	12	3	26	150	

Z4 FRESA TÓRICA EXTRALARGA

- EN** Z4 CORNER RADIUS END MILL | Extralong Series
FR Z4 FRAISE TORIQUE | Extra Longue
DE Z4 TORUSFRÄSER | Extra Lange

ES Acero, Acero Inoxidable, Fundición Gris, Cobre, Titanio y Aceros hasta 62 HRC.

EN Steel, Stainless Steel, Cast Iron, Cooper, Titanium and Hardened Steels up to 62 HRC.

FR Acier, Acier Inoxydable, Fonte Grise, Cuivre, Titane et Acier Jusq'ua 62 HRC.

DE Stahl, Rostfreier Stahl, Gubeisen, Kupfer, Titan, Gehärteter Stahl 62 HRC.

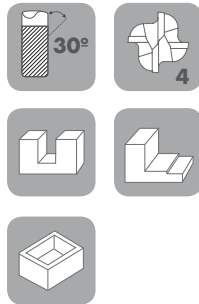

ALTIN NANO



SERIE LARGA

Ref.	Dimensiones (mm)					Precio €
	Dc	d	R	Lc	L	
4 Flutes (Z4)						
H-SEM4060XL-r0,5	6	6	0,5	13	150	
H-SEM4060XL-r1,0	6	6	1	13	150	
H-SEM4060XL-r1,5	6	6	1,5	13	150	
H-SEM4060XL-r2,0	6	6	2	13	150	
H-SEM4080XL-r0,5	8	8	0,5	19	150	
H-SEM4080XL-r1,0	8	8	1	19	150	
H-SEM4080XL-r1,5	8	8	1,5	19	150	
H-SEM4080XL-r2,0	8	8	2	19	150	
H-SEM4100XL-r0,5	10	10	0,5	22	150	
H-SEM4100XL-r1,0	10	10	1	22	150	
H-SEM4100XL-r2,0	10	10	2	22	150	
H-SEM4100XL-r3,0	10	10	3	22	150	
H-SEM4120XL-r0,5	12	12	0,5	26	150	
H-SEM4120XL-r1,0	12	12	1	26	150	
H-SEM4120XL-r2,0	12	12	2	26	150	
H-SEM4120XL-r3,0	12	12	3	26	150	

I Z2 FRESA TÓRICA CUELLO-MANGO D6

- EN** Z2 CORNER RADIUS END MILL | SHANK D6
FR Z2 FRAISE TORIQUE
DE Z2 TORUSFRÄSER

ES Acero, Acero Inoxidable, Fundición Gris, Cobre, Titanio y Aceros hasta 62 HRC.

EN Steel, Stainless Steel, Cast Iron, Cooper, Titanium and Hardened Steels up to 62 HRC.

FR Acier, Acier Inoxydable, Fonte Grise, Cuivre, Titane et Acier Jusq'ua 62 HRC.

DE Stahl, Rostfreier Stahl, Gubeisen, Kupfer, Titan, Gehärteter Stahl 62 HRC.

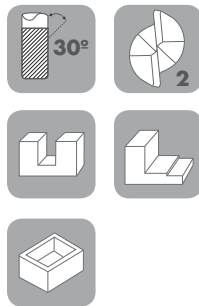

ALTIN NANO

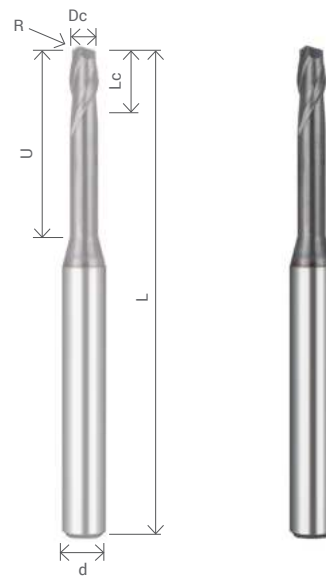

CUELLO REFORZADO Y REBAJADO

Ref.	Dimensiones (mm)						Precio €
	Dc	d	R	Lc	U	L	
2 Flutes (Z2)							
H-SEM2010X-r0,1-U5	1	6	0,1	1,5	5	57	
H-SEM2010X-r0,1-U12	1	6	0,1	1,5	12	65	
H-SEM2010X-r0,1-U20	1	6	0,1	1,5	20	65	
H-SEM2010X-r0,25-U5	1	6	0,25	1,5	5	57	
H-SEM2010X-r0,25-U12	1	6	0,25	1,5	12	65	
H-SEM2010X-r0,25-U20	1	6	0,25	1,5	20	65	
H-SEM2015X-r0,1-U5	1,5	6	0,1	2	5	57	
H-SEM2015X-r0,1-U12	1,5	6	0,1	2	12	65	
H-SEM2015X-r0,1-U20	1,5	6	0,1	2	20	65	
H-SEM2015X-r0,1-U25	1,5	6	0,1	2	25	65	
H-SEM2015X-r0,3-U5	1,5	6	0,3	2	5	57	
H-SEM2015X-r0,3-U12	1,5	6	0,3	2	12	65	
H-SEM2015X-r0,3-U20	1,5	6	0,3	2	20	65	
H-SEM2015X-r0,3-U25	1,5	6	0,3	2	25	65	
H-SEM2020X-r0,2-U10	2	6	0,2	3	10	80	

I Z2 FRESA TÓRICA CUELLO-MANGO D6

EN Z2 CORNER RADIUS END MILL | SHANK D6

FR Z2 FRAISE TORIQUE

DE Z2 TORUSFRÄSER



Ref.	Dimensiones (mm)						L	Precio €
	2 Flutes (Z2)	Dc	d	R	Lc	U		
H-SEM2020X-r0,2-U15	2	6	0,2	3	15	80		
H-SEM2020X-r0,2-U20	2	6	0,2	3	20	80		
H-SEM2020X-r0,2-U25	2	6	0,2	3	25	80		
H-SEM2020X-r0,2-U30	2	6	0,2	3	30	80		
H-SEM2020X-r0,2-U40	2	6	0,2	3	40	80		
H-SEM2020X-r0,5-U10	2	6	0,5	3	10	80		
H-SEM2020X-r0,5-U15	2	6	0,5	3	15	80		
H-SEM2020X-r0,5-U20	2	6	0,5	3	20	80		
H-SEM2020X-r0,5-U25	2	6	0,5	3	25	80		
H-SEM2020X-r0,5-U30	2	6	0,5	3	30	80		
H-SEM2020X-r0,5-U40	2	6	0,5	3	40	80		
H-SEM2030X-r0,2-U15	3	6	0,2	5	15	80		
H-SEM2030X-r0,2-U20	3	6	0,2	5	20	80		
H-SEM2030X-r0,2-U25	3	6	0,2	5	25	80		
H-SEM2030X-r0,2-U30	3	6	0,2	5	30	80		
H-SEM2030X-r0,2-U40	3	6	0,2	5	40	80		
H-SEM2030X-r0,5-U15	3	6	0,5	5	15	80		
H-SEM2030X-r0,5-U20	3	6	0,5	5	20	80		
H-SEM2030X-r0,5-U25	3	6	0,5	5	25	80		
H-SEM2030X-r0,5-U30	3	6	0,5	5	30	80		
H-SEM2030X-r0,5-U40	3	6	0,5	5	40	80		
H-SEM2040X-r0,2-U20	4	6	0,2	6	20	80		
H-SEM2040X-r0,2-U30	4	6	0,2	6	30	80		
H-SEM2040X-r0,2-U40	4	6	0,2	6	40	80		
H-SEM2040X-r0,5-U20	4	6	0,5	6	20	80		
H-SEM2040X-r0,5-U30	4	6	0,5	6	30	80		
H-SEM2040X-r0,5-U40	4	6	0,5	6	40	80		

I Z2 FRESA TÓRICA CUELLO-MANGO D6

EN Z2 CORNER RADIUS END MILL | SHANK D6

FR Z2 FRAISE TORIQUE

DE Z2 TORUSFRÄSER



Ref.	Dimensiones (mm)						Precio €
	Dc	d	R	Lc	U	L	
2 Flutes (Z2)							
H-SEM2040X-r1,0-U20	4	6	1	6	20	80	
H-SEM2040X-r1,0-U30	4	6	1	6	30	80	
H-SEM2040X-r1,0-U40	4	6	1	6	40	80	
H-SEM2050X-r0,2-U25	5	6	0,2	7	25	80	
H-SEM2050X-r0,2-U30	5	6	0,2	7	30	80	
H-SEM2050X-r0,2-U40	5	6	0,2	7	40	80	
H-SEM2050X-r0,5-U25	5	6	0,5	7	25	80	
H-SEM2050X-r0,5-U30	5	6	0,5	7	30	80	
H-SEM2050X-r0,5-U40	5	6	0,5	7	40	80	
H-SEM2050X-r1,0-U25	5	6	1	7	25	80	
H-SEM2050X-r1,0-U30	5	6	1	7	30	80	
H-SEM2050X-r1,0-U40	5	6	1	7	40	80	



DISEÑO
CONTROL
FABRICACIÓN
DISTRIBUCIÓN

I Z4 FRESA TÓRICA CUELLO-MANGO D6

EN Z4 CORNER RADIUS END MILL | SHANK D6

FR Z4 FRAISE TORIQUE

DE Z4 TORUSFRÄSER

ES Acero, Acero Inoxidable, Fundición Gris, Cobre, Titanio y Aceros hasta 62 HRC.

EN Steel, Stainless Steel, Cast Iron, Cooper, Titanium and Hardened Steels up to 62 HRC.

FR Acier, Acier Inoxydable, Fonte Grise, Cuivre, Titane et Acier Jusq'ua 62 HRC.

DE Stahl, Rostfreier Stahl, Gubeisen, Kupfer, Titan, Gehärteter Stahl 62 HRC.

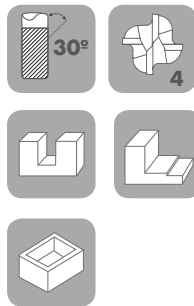

ALTiN NANO

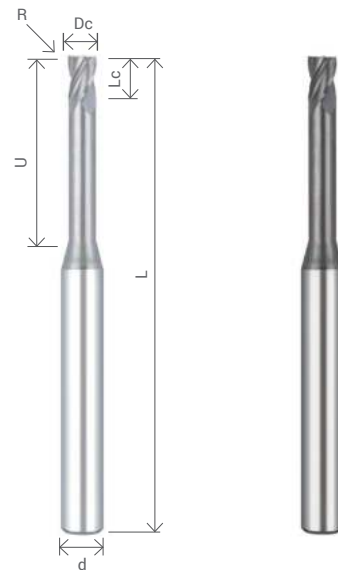

CUELLO REFORZADO Y REBAJADO

Ref.	Dimensiones (mm)						Precio €
	Dc	d	R	Lc	U	L	
4 Flutes (Z4)							
H-SEM4020X-r0,2-U10	2	6	0,2	3	10	80	
H-SEM4020X-r0,2-U15	2	6	0,2	3	15	80	
H-SEM4020X-r0,2-U20	2	6	0,2	3	20	80	
H-SEM4020X-r0,2-U25	2	6	0,2	3	25	80	
H-SEM4020X-r0,2-U30	2	6	0,2	3	30	80	
H-SEM4020X-r0,2-U40	2	6	0,2	3	40	80	
H-SEM4020X-r0,5-U10	2	6	0,5	3	10	80	
H-SEM4020X-r0,5-U15	2	6	0,5	3	15	80	
H-SEM4020X-r0,5-U20	2	6	0,5	3	20	80	
H-SEM4020X-r0,5-U25	2	6	0,5	3	25	80	
H-SEM4020X-r0,5-U30	2	6	0,5	3	30	80	
H-SEM4020X-r0,5-U40	2	6	0,5	3	40	80	
H-SEM4030X-r0,2-U15	3	6	0,2	5	15	80	
H-SEM4030X-r0,2-U20	3	6	0,2	5	20	80	
H-SEM4030X-r0,2-U25	3	6	0,2	5	25	80	

I Z4 FRESA TÓRICA CUELLO-MANGO D6

EN Z4 CORNER RADIUS END MILL | SHANK D6

FR Z4 FRAISE TORIQUE

DE Z4 TORUSFRÄSER



Ref.	Dimensiones (mm)						Precio €
	4 Flutes (Z4)	Dc	d	R	Lc	U	
H-SEM4030X-r0,2-U30	3	6	0,2	5	30	80	
H-SEM4030X-r0,2-U40	3	6	0,2	5	40	80	
H-SEM4030X-r0,5-U15	3	6	0,5	5	15	80	
H-SEM4030X-r0,5-U20	3	6	0,5	5	20	80	
H-SEM4030X-r0,5-U25	3	6	0,5	5	25	80	
H-SEM4030X-r0,5-U30	3	6	0,5	5	30	80	
H-SEM4030X-r0,5-U40	3	6	0,5	5	40	80	
H-SEM4040X-r0,2-U20	4	6	0,2	6	20	80	
H-SEM4040X-r0,2-U30	4	6	0,2	6	30	80	
H-SEM4040X-r0,2-U40	4	6	0,2	6	40	80	
H-SEM4040X-r0,5-U20	4	6	0,5	6	20	80	
H-SEM4040X-r0,5-U30	4	6	0,5	6	30	80	
H-SEM4040X-r0,5-U40	4	6	0,5	6	40	80	
H-SEM4040X-r1,0-U20	4	6	1	6	20	80	
H-SEM4040X-r1,0-U30	4	6	1	6	30	80	
H-SEM4040X-r1,0-U40	4	6	1	6	40	80	
H-SEM4050X-r0,2-U25	5	6	0,2	7	25	80	
H-SEM4050X-r0,2-U30	5	6	0,2	7	30	80	
H-SEM4050X-r0,2-U40	5	6	0,2	7	40	80	
H-SEM4050X-r0,5-U25	5	6	0,5	7	25	80	
H-SEM4050X-r0,5-U30	5	6	0,5	7	30	80	
H-SEM4050X-r0,5-U40	5	6	0,5	7	40	80	
H-SEM4050X-r1,0-U25	5	6	1	7	25	80	
H-SEM4050X-r1,0-U30	5	6	1	7	30	80	
H-SEM4050X-r1,0-U40	5	6	1	7	40	80	

I Z2 FRESA TÓRICA CUELLO REBAJADO Serie Larga

EN Z2 CORNER RADIUS END MILL | REDUCED NECK | Long Series

FR Z2 FRAISE TORIQUE | Longue

DE Z2 TORUSFRÄSE | Lange

ES Acero, Acero Inoxidable, Fundición Gris, Cobre, Titanio y Aceros hasta 62 HRC.

EN Steel, Stainless Steel, Cast Iron, Cooper, Titanium and Hardened Steels up to 62 HRC.

FR Acier, Acier Inoxydable, Fonte Grise, Cuivre, Titane et Acier Jusq'ua 62 HRC.

DE Stahl, Rostfreier Stahl, Gubeisen, Kupfer, Titan, Gehärteter Stahl 62 HRC.



ALTIN NANO

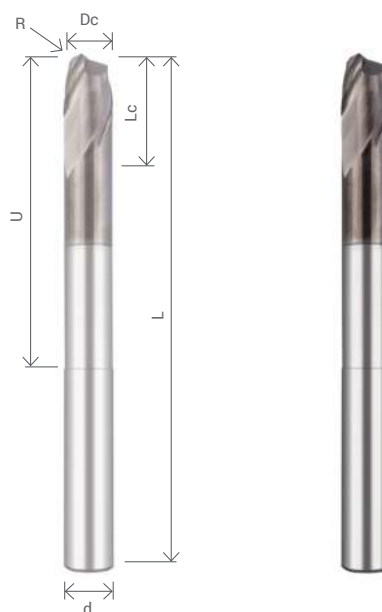

CUELLO REBAJADO

Ref.	Dimensiones (mm)						Precio €
	Dc	d	R	Lc	U	L	
2 Flutes (Z2)							
H-SEM2060X-r0,2-U20	6	6	0,2	7	20	80	
H-SEM2060X-r0,2-U30	6	6	0,2	7	30	80	
H-SEM2060X-r0,2-U45	6	6	0,2	7	45	80	
H-SEM2060X-r0,5-U20	6	6	0,5	7	20	80	
H-SEM2060X-r0,5-U30	6	6	0,5	7	30	80	
H-SEM2060X-r0,5-U45	6	6	0,5	7	45	80	
H-SEM2060X-r1,0-U20	6	6	1	7	20	80	
H-SEM2060X-r1,0-U30	6	6	1	7	30	80	
H-SEM2060X-r1,0-U45	6	6	1	7	45	80	
H-SEM2060X-r1,5-U20	6	6	1,5	7	20	80	
H-SEM2060X-r1,5-U30	6	6	1,5	7	30	80	
H-SEM2060X-r1,5-U45	6	6	1,5	7	45	80	
H-SEM2060X-r2,0-U20	6	6	2	7	20	80	
H-SEM2060X-r2,0-U30	6	6	2	7	30	80	
H-SEM2060X-r2,0-U45	6	6	2	7	45	80	

I Z2 FRESA TÓRICA CUELLO REBAJADO Serie Larga

EN Z2 CORNER RADIUS END MILL | REDUCED NECK | Long Series

FR Z2 FRAISE TORIQUE | Longue

DE Z2 TORUSFRÄSER | Lange



Ref.	Dimensiones (mm)						Precio €
	Dc	d	R	Lc	U	L	
2 Flutes (Z2)							
H-SEM2080X-r0,5-U25	8	8	0,5	9	25	90	
H-SEM2080X-r0,5-U40	8	8	0,5	9	40	90	
H-SEM2080X-r0,5-U55	8	8	0,5	9	55	90	
H-SEM2080X-r1,0-U25	8	8	1	9	25	90	
H-SEM2080X-r1,0-U40	8	8	1	9	40	90	
H-SEM2080X-r1,0-U55	8	8	1	9	55	90	
H-SEM2080X-r1,5-U25	8	8	1,5	9	25	90	
H-SEM2080X-r1,5-U40	8	8	1,5	9	40	90	
H-SEM2080X-r1,5-U55	8	8	1,5	9	55	90	
H-SEM2080X-r2,0-U25	8	8	2	9	25	90	
H-SEM2080X-r2,0-U40	8	8	2	9	40	90	
H-SEM2080X-r2,0-U55	8	8	2	9	55	90	
H-SEM2100X-r0,5-U30	10	10	0,5	11	30	100	
H-SEM2100X-r0,5-U45	10	10	0,5	11	45	100	
H-SEM2100X-r0,5-U60	10	10	0,5	11	60	100	
H-SEM2100X-r1,0-U30	10	10	1	11	30	100	
H-SEM2100X-r1,0-U45	10	10	1	11	45	100	
H-SEM2100X-r1,0-U60	10	10	1	11	60	100	
H-SEM2100X-r2,0-U30	10	10	2	11	30	100	
H-SEM2100X-r2,0-U45	10	10	2	11	45	100	
H-SEM2100X-r2,0-U60	10	10	2	11	60	100	
H-SEM2100X-r3,0-U30	10	10	3	11	30	100	
H-SEM2100X-r3,0-U45	10	10	3	11	45	100	
H-SEM2100X-r3,0-U60	10	10	3	11	60	100	
H-SEM2120X-r0,5-U30	12	12	0,5	13	30	100	
H-SEM2120X-r0,5-U45	12	12	0,5	13	45	100	
H-SEM2120X-r0,5-U60	12	12	0,5	13	60	100	
H-SEM2120X-r1,0-U30	12	12	1	13	30	100	

I Z2 FRESA TÓRICA CUELLO REBAJADO Serie Larga

EN Z2 CORNER RADIUS END MILL | REDUCED NECK | Long Series

FR Z2 FRAISE TORIQUE | Longue

DE Z2 TORUSFRÄSER | Lange



Ref.	Dimensiones (mm)						Precio €
2 Flutes (Z2)	Dc	d	R	Lc	U	L	
H-SEM2120X-r1,0-U45	12	12	1	13	45	100	
H-SEM2120X-r1,0-U60	12	12	1	13	60	100	
H-SEM2120X-r2,0-U30	12	12	2	13	30	100	
H-SEM2120X-r2,0-U45	12	12	2	13	45	100	
H-SEM2120X-r2,0-U60	12	12	2	13	60	100	
H-SEM2120X-r3,0-U30	12	12	3	13	30	100	
H-SEM2120X-r3,0-U45	12	12	3	13	45	100	
H-SEM2120X-r3,0-U60	12	12	3	13	60	100	
H-SEM2160X-r0,5-U75	16	16	0,5	20	75	150	
H-SEM2160X-r1,0-U75	16	16	1	20	75	150	
H-SEM2160X-r2,0-U75	16	16	2	20	75	150	
H-SEM2160X-r3,0-U75	16	16	2	20	75	150	
H-SEM2160X-r4,0-U75	16	16	4	20	75	150	

Z4 FRESA TÓRICA CUELLO REBAJADO Serie Larga

EN Z4 CORNER RADIUS END MILL | REDUCED NECK | Long Series

FR Z4 FRAISE TORIQUE | Longue

DE Z4 TORUSFRÄSER | Lange

ES Acero, Acero Inoxidable, Fundición Gris, Cobre, Titanio y Aceros hasta 62 HRC.

EN Steel, Stainless Steel, Cast Iron, Cooper, Titanium and Hardened Steels up to 62 HRC.

FR Acier, Acier Inoxydable, Fonte Grise, Cuivre, Titane et Acier Jusq'ua 62 HRC.

DE Stahl, Rostfreier Stahl, Gubeisen, Kupfer, Titan, Gehärteter Stahl 62 HRC.

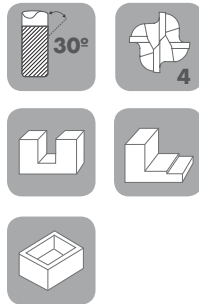

ALTIN NANO



CUELLO REBAJADO

Ref.	Dimensiones (mm)						Precio €
	Dc	d	R	Lc	U	L	
4 Flutes (Z4)							
H-SEM4060X-r0,2-U20	6	6	0,2	7	20	80	
H-SEM4060X-r0,2-U30	6	6	0,2	7	30	80	
H-SEM4060X-r0,2-U45	6	6	0,2	7	45	80	
H-SEM4060X-r0,5-U20	6	6	0,5	7	20	80	
H-SEM4060X-r0,5-U30	6	6	0,5	7	30	80	
H-SEM4060X-r0,5-U45	6	6	0,5	7	45	80	
H-SEM4060X-r1,0-U20	6	6	1	7	20	80	
H-SEM4060X-r1,0-U30	6	6	1	7	30	80	
H-SEM4060X-r1,0-U45	6	6	1	7	45	80	
H-SEM4060X-r1,5-U20	6	6	1,5	7	20	80	
H-SEM4060X-r1,5-U30	6	6	1,5	7	30	80	
H-SEM4060X-r1,5-U45	6	6	1,5	7	45	80	
H-SEM4060X-r2,0-U20	6	6	2	7	20	80	
H-SEM4060X-r2,0-U30	6	6	2	7	30	80	

I Z4 FRESA TÓRICA CUELLO REBAJADO Serie Larga

EN Z4 CORNER RADIUS END MILL | REDUCED NECK | Long Series

FR Z4 FRAISE TORIQUE | Longue

DE Z4 TORUSFRÄSER | Lange



Ref.	Dimensiones (mm)						Precio €
	Dc	d	R	Lc	U	L	
4 Flutes (Z4)							
H-SEM4060X-r2,0-U45	6	6	2	7	45	80	
H-SEM4080X-r0,5-U25	8	8	0,5	9	25	90	
H-SEM4080X-r0,5-U40	8	8	0,5	9	40	90	
H-SEM4080X-r0,5-U55	8	8	0,5	9	55	90	
H-SEM4080X-r1,0-U25	8	8	1	9	25	90	
H-SEM4080X-r1,0-U40	8	8	1	9	40	90	
H-SEM4080X-r1,0-U55	8	8	1	9	55	90	
H-SEM4080X-r1,5-U25	8	8	1,5	9	25	90	
H-SEM4080X-r1,5-U40	8	8	1,5	9	40	90	
H-SEM4080X-r1,5-U55	8	8	1,5	9	55	90	
H-SEM4080X-r2,0-U25	8	8	2	9	25	90	
H-SEM4080X-r2,0-U40	8	8	2	9	40	90	
H-SEM4080X-r2,0-U55	8	8	2	9	55	90	
H-SEM4100X-r0,5-U30	10	10	0,5	11	30	100	
H-SEM4100X-r0,5-U45	10	10	0,5	11	45	100	
H-SEM4100X-r0,5-U60	10	10	0,5	11	60	100	
H-SEM4100X-r1,0-U30	10	10	1	11	30	100	
H-SEM4100X-r1,0-U45	10	10	1	11	45	100	
H-SEM4100X-r1,0-U60	10	10	1	11	60	100	
H-SEM4100X-r2,0-U30	10	10	2	11	30	100	
H-SEM4100X-r2,0-U45	10	10	2	11	45	100	
H-SEM4100X-r2,0-U60	10	10	2	11	60	100	
H-SEM4100X-r3,0-U30	10	10	3	11	30	100	
H-SEM4100X-r3,0-U45	10	10	3	11	45	100	
H-SEM4100X-r3,0-U60	10	10	3	11	60	100	

Z4 FRESA TÓRICA CUELLO REBAJADO Serie Larga

EN Z4 CORNER RADIUS END MILL | REDUCED NECK | Long Series

FR Z4 FRAISE TORIQUE | Longue

DE Z4 TORUSFRÄSER | Lange



Ref.	Dimensiones (mm)						Precio €
	Dc	d	R	Lc	U	L	
4 Flutes (Z4)							
H-SEM4120X-r0,5-U30	12	12	0,5	13	30	100	
H-SEM4120X-r0,5-U45	12	12	0,5	13	45	100	
H-SEM4120X-r0,5-U60	12	12	0,5	13	60	100	
H-SEM4120X-r1,0-U30	12	12	1	13	30	100	
H-SEM4120X-r1,0-U45	12	12	1	13	45	100	
H-SEM4120X-r1,0-U60	12	12	1	13	60	100	
H-SEM4120X-r2,0-U30	12	12	2	13	30	100	
H-SEM4120X-r2,0-U45	12	12	2	13	45	100	
H-SEM4120X-r2,0-U60	12	12	2	13	60	100	
H-SEM4120X-r3,0-U30	12	12	3	13	30	100	
H-SEM4120X-r3,0-U45	12	12	3	13	45	100	
H-SEM4120X-r3,0-U60	12	12	3	13	60	100	
H-SEM4160X-r0,5-U75	16	16	0,5	20	75	150	
H-SEM4160X-r1,0-U75	16	16	1	20	75	150	
H-SEM4160X-r2,0-U75	16	16	2	20	75	150	
H-SEM4160X-r3,0-U75	16	16	2	20	75	150	
H-SEM4160X-r4,0-U75	16	16	4	20	75	150	

I Z4 FRESA TÓRICA CUELLO REBAJADO Serie Normal

- EN Z4 CORNER RADIUS END MILL | REDUCED NECK | Normal Series
 FR Z4 FRAISE TORIQUE | Normale
 DE Z4 TORUSFRÄSER | Normale

ES Acero, Acero Inoxidable, Fundición Gris, Cobre, Titanio y Aceros hasta 62 HRC.

EN Steel, Stainless Steel, Cast Iron, Cooper, Titanium and Hardened Steels up to 62 HRC.

FR Acier, Acier Inoxydable, Fonte Grise, Cuivre, Titane et Acier Jusq'ua 62 HRC.

DE Stahl, Rostfreier Stahl, Gubeisen, Kupfer, Titan, Gehärteter Stahl 62 HRC.

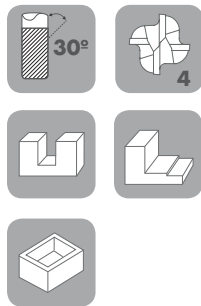

ALTIN NANO

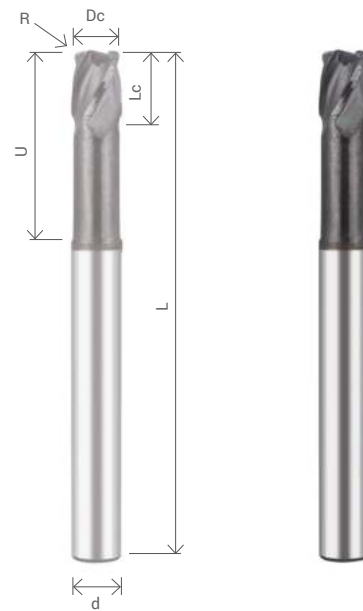

CUELLO REBAJADO

Ref.	Dimensiones (mm)						Precio €
	Dc	d	R	Lc	U	L	
4 Flutes (Z4)							
H-SEM4020S-r0,2-U21	2	6	0,2	3	21	57	
H-SEM4020S-r0,5-U21	2	6	0,5	3	21	57	
H-SEM4030S-r0,2-U21	3	6	0,2	5	21	57	
H-SEM4030S-r0,5-U21	3	6	0,5	5	21	57	
H-SEM4040S-r0,5-U21	4	6	0,5	6	21	57	
H-SEM4040S-r1,0-U21	4	6	1	6	21	57	
H-SEM4050S-r0,5-U21	5	6	0,5	7	21	57	
H-SEM4050S-r1,0-U21	5	6	1	7	21	57	
H-SEM4060S-r0,5-U21	6	6	0,5	7	21	57	
H-SEM4060S-r1,0-U21	6	6	1	7	21	57	
H-SEM4060S-r1,5-U21	6	6	1,5	7	21	57	
H-SEM4060S-r2,0-U21	6	6	2	7	21	57	
H-SEM4080S-r0,5-U27	8	8	0,5	9	27	63	
H-SEM4080S-r1,0-U27	8	8	1	9	27	63	
H-SEM4080S-r1,5-U27	8	8	1,5	9	27	63	

I Z4 FRESA TÓRICA CUELLO REBAJADO Serie Normal

EN Z4 CORNER RADIUS END MILL | REDUCED NECK | Normal Series

FR Z4 FRAISE TORIQUE | Normale

DE Z4 TORUSFRÄSER | Normale



Ref.	Dimensiones (mm)						Precio €
	4 Flutes (Z4)	Dc	d	R	Lc	U	
H-SEM4080S-r2,0-U27		8	8	2	9	27	63
H-SEM4100S-r0,5-U32		10	10	0,5	11	32	72
H-SEM4100S-r1,0-U32		10	10	1	11	32	72
H-SEM4100S-r1,5-U32		10	10	1,5	11	32	72
H-SEM4100S-r2,0-U32		10	10	2	11	32	72
H-SEM4120S-r0,5-U38		12	12	0,5	13	38	83
H-SEM4120S-r1,0-U38		12	12	1	13	38	83
H-SEM4120S-r1,5-U38		12	12	1,5	13	38	83
H-SEM4120S-r2,0-U38		12	12	2	13	38	83
H-SEM4120S-r3,0-U38		12	12	3	13	38	83
H-SEM4160S-r0,5-U44		16	16	0,5	17	44	92
H-SEM4160S-r1,0-U44		16	16	1	17	44	92
H-SEM4160S-r2,0-U44		16	16	2	17	44	92
H-SEM4160S-r3,0-U44		16	16	3	17	44	92
H-SEM4160S-r4,0-U44		16	16	4	17	44	92

I Z2 FRESA TÓRICA CONICA A 1°

EN Z2 CORNER RADIUS END MILL | 1° TAPER

FR Z2 FRAISE TORIQUE | 1°

DE Z2 TORUSFRÄSER | 1°

ES Acero, Acero Inoxidable, Fundición Gris, Cobre, Titanio y Aceros hasta 62 HRC.

EN Steel, Stainless Steel, Cast Iron, Cooper, Titanium and Hardened Steels up to 62 HRC.

FR Acier, Acier Inoxydable, Fonte Grise, Cuivre, Titane et Acier Jusqu'à 62 HRC.

DE Stahl, Rostfreier Stahl, Gubeisen, Kupfer, Titan, Gehärteter Stahl 62 HRC.

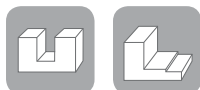

ALTiN NANO

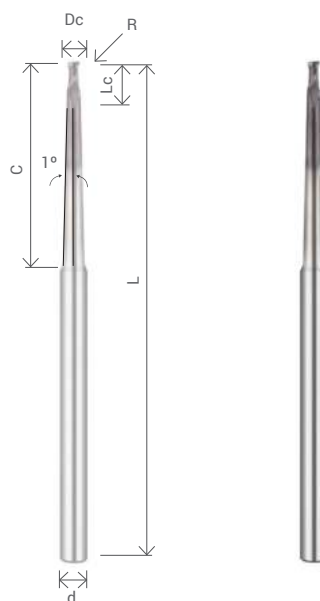

1° CONICIDAD AL RÁDIO

Ref.	Dimensiones (mm)						Precio €
	Dc	d	R	Lc	C	L	
2 Flutes (Z2)							
H-CEM2015XL-r0,3-C43x1°	1,5	6	0,3	2	43	109	
H-CEM2015XL-r0,3-C53x1°	1,5	6	0,3	2	53	109	
H-CEM2015XL-r0,3-C63x1°	1,5	6	0,3	2	63	109	
H-CEM2020XL-r0,5-C43x1°	2	6	0,5	3	43	109	
H-CEM2020XL-r0,5-C53x1°	2	6	0,5	3	53	109	
H-CEM2020XL-r0,5-C63x1°	2	6	0,5	3	63	109	
H-CEM2030XL-r0,5-C44x1°	3	6	0,5	5	44	109	
H-CEM2030XL-r0,5-C55x1°	3	6	0,5	5	55	109	
H-CEM2030XL-r0,5-C65x1°	3	6	0,5	5	65	109	
H-CEM2040XL-r0,5-C45x1°	4	6	0,5	6	45	109	
H-CEM2040XL-r0,5-C55x1°	4	6	0,5	6	55	109	
H-CEM2040XL-r0,5-C65x1°	4	6	0,5	6	65	109	
H-CEM2040XL-r1,0-C45x1°	4	6	1	6	45	109	
H-CEM2040XL-r1,0-C55x1°	4	6	1	6	55	109	
H-CEM2040XL-r1,0-C65x1°	4	6	1	6	65	109	

I Z2 FRESA TÓRICA CONICA A 1°

EN Z2 CORNER RADIUS END MILL | 1° TAPER

FR Z2 FRAISE TORIQUE | 1°

DE Z2 TORUSFRÄSER | 1°



Ref.	Dimensiones (mm)						Precio €
	Dc	d	R	Lc	C	L	
2 Flutes (Z2)							
H-CEM2050XL-r0,5-C45x1°	5	8	0,5	7	45	109	
H-CEM2050XL-r0,5-C55x1°	5	8	0,5	7	55	109	
H-CEM2050XL-r0,5-C70x1°	5	8	0,5	7	70	109	
H-CEM2050XL-r1,0-C45x1°	5	8	1	7	45	109	
H-CEM2050XL-r1,0-C55x1°	5	8	1	7	55	109	
H-CEM2050XL-r1,0-C70x1°	5	8	1	7	70	109	
H-CEM2060XL-r0,5-C48x1°	6	8	0,5	9	48	109	
H-CEM2060XL-r0,5-C55x1°	6	8	0,5	9	55	109	
H-CEM2060XL-r0,5-C70x1°	6	8	0,5	9	70	109	
H-CEM2060XL-r1,0-C48x1°	6	8	1	9	48	109	
H-CEM2060XL-r1,0-C55x1°	6	8	1	9	55	109	
H-CEM2060XL-r1,0-C70x1°	6	8	1	9	70	109	
H-CEM2060XL-r1,5-C48x1°	6	8	1,5	9	48	109	
H-CEM2060XL-r1,5-C55x1°	6	8	1,5	9	55	109	
H-CEM2060XL-r1,5-C70x1°	6	8	1,5	9	70	109	
H-CEM2080XL-r0,5-C48x1°	8	10	0,5	10	48	109	
H-CEM2080XL-r0,5-C55x1°	8	10	0,5	10	55	109	
H-CEM2080XL-r0,5-C70x1°	8	10	0,5	10	70	109	
H-CEM2080XL-r1,0-C48x1°	8	10	1	10	48	109	
H-CEM2080XL-r1,0-C55x1°	8	10	1	10	55	109	
H-CEM2080XL-r1,0-C70x1°	8	10	1	10	70	109	
H-CEM2080XL-r1,5-C48x1°	8	10	1,5	10	48	109	
H-CEM2080XL-r1,5-C55x1°	8	10	1,5	10	55	109	
H-CEM2080XL-r1,5-C70x1°	8	10	1,5	10	70	109	
H-CEM2080XL-r2,0-C48x1°	8	10	2	10	48	109	
H-CEM2080XL-r2,0-C55x1°	8	10	2	10	55	109	
H-CEM2080XL-r2,0-C70x1°	8	10	2	10	70	109	

I Z4 FRESA TÓRICA CONICA A 1°

- EN Z4 CORNER RADIUS END MILL | 1° TAPER
FR Z4 FRAISE TORIQUE | 1°
DE Z4 TORUSFRÄSER | 1°

- ES Acero, Acero Inoxidable, Fundición Gris, Cobre, Titanio y Aceros hasta 62 HRC.
EN Steel, Stainless Steel, Cast Iron, Cooper, Titanium and Hardened Steels up to 62 HRC.
FR Acier, Acier Inoxydable, Fonte Grise, Cuivre, Titane et Acier Jusq'ua 62 HRC.
DE Stahl, Rostfreier Stahl, Gubeisen, Kupfer, Titan, Gehärteter Stahl 62 HRC.

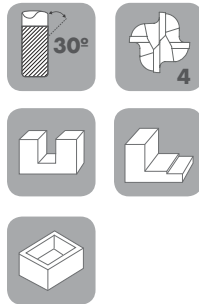

ALTiN NANO

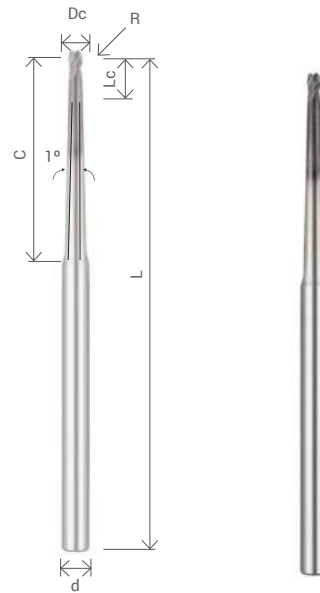

1° CONICIDAD AL RÁDIO

Ref.	Dimensiones (mm)						Precio €
4 Flutes (Z4)	Dc	d	R	Lc	C	L	
H-CEM4020XL-r0,5-C43x1°	2	6	0,5	3	43	109	
H-CEM4020XL-r0,5-C53x1°	2	6	0,5	3	53	109	
H-CEM4020XL-r0,5-C63x1°	2	6	0,5	3	63	109	
H-CEM4030XL-r0,5-C44x1°	3	6	0,5	5	44	109	
H-CEM4030XL-r0,5-C55x1°	3	6	0,5	5	55	109	
H-CEM4030XL-r0,5-C65x1°	3	6	0,5	5	65	109	
H-CEM4040XL-r0,5-C45x1°	4	6	0,5	6	45	109	
H-CEM4040XL-r0,5-C55x1°	4	6	0,5	6	55	109	
H-CEM4040XL-r0,5-C65x1°	4	6	0,5	6	65	109	
H-CEM4040XL-r1,0-C45x1°	4	6	1	6	45	109	
H-CEM4040XL-r1,0-C55x1°	4	6	1	6	55	109	
H-CEM4040XL-r1,0-C65x1°	4	6	1	6	65	109	
H-CEM4050XL-r0,5-C45x1°	5	8	0,5	7	45	109	
H-CEM4050XL-r0,5-C55x1°	5	8	0,5	7	55	109	
H-CEM4050XL-r0,5-C70x1°	5	8	0,5	7	70	109	

I Z4 FRESA TÓRICA CONICA A 1°

EN Z4 CORNER RADIUS END MILL | 1° TAPER

FR Z4 FRAISE TORIQUE | 1°

DE Z4 TORUSFRÄSER | 1°



Ref.	Dimensiones (mm)						Precio €
	4 Flutes (Z4)	Dc	d	R	Lc	C	
H-CEM4050XL-r1,0-C45x1°	5	8	1	7	45	109	
H-CEM4050XL-r1,0-C55x1°	5	8	1	7	55	109	
H-CEM4050XL-r1,0-C70x1°	5	8	1	7	70	109	
H-CEM4060XL-r0,5-C48x1°	6	8	0,5	9	48	109	
H-CEM4060XL-r0,5-C55x1°	6	8	0,5	9	55	109	
H-CEM4060XL-r0,5-C70x1°	6	8	0,5	9	70	109	
H-CEM4060XL-r1,0-C48x1°	6	8	1	9	48	109	
H-CEM4060XL-r1,0-C55x1°	6	8	1	9	55	109	
H-CEM4060XL-r1,0-C70x1°	6	8	1	9	70	109	
H-CEM4060XL-r1,5-C48x1°	6	8	1,5	9	48	109	
H-CEM4060XL-r1,5-C55x1°	6	8	1,5	9	55	109	
H-CEM4060XL-r1,5-C70x1°	6	8	1,5	9	70	109	
H-CEM4080XL-r0,5-C48x1°	8	10	0,5	10	48	109	
H-CEM4080XL-r0,5-C55x1°	8	10	0,5	10	55	109	
H-CEM4080XL-r0,5-C70x1°	8	10	0,5	10	70	109	
H-CEM4080XL-r1,0-C48x1°	8	10	1	10	48	109	
H-CEM4080XL-r1,0-C55x1°	8	10	1	10	55	109	
H-CEM4080XL-r1,0-C70x1°	8	10	1	10	70	109	
H-CEM4080XL-r1,5-C48x1°	8	10	1,5	10	48	109	
H-CEM4080XL-r1,5-C55x1°	8	10	1,5	10	55	109	
H-CEM4080XL-r1,5-C70x1°	8	10	1,5	10	70	109	
H-CEM4080XL-r2,0-C48x1°	8	10	2	10	48	109	
H-CEM4080XL-r2,0-C55x1°	8	10	2	10	55	109	
H-CEM4080XL-r2,0-C70x1°	8	10	2	10	70	109	

I Z2 FRESA TÓRICA CONICA A 1,5°

- EN Z2 CORNER RADIUS END MILL | 1,5° TAPER
 FR Z2 FRAISE TORIQUE | 1,5°
 DE Z2 TORUSFRÄSER | 1,5°

- ES Acero, Acero Inoxidable, Fundición Gris, Cobre, Titanio y Aceros hasta 62 HRC.
 EN Steel, Stainless Steel, Cast Iron, Cooper, Titanium and Hardened Steels up to 62 HRC.
 FR Acier, Acier Inoxydable, Fonte Grise, Cuivre, Titane et Acier Jusq'ua 62 HRC.
 DE Stahl, Rostfreier Stahl, Gubeisen, Kupfer, Titan, Gehärteter Stahl 62 HRC.

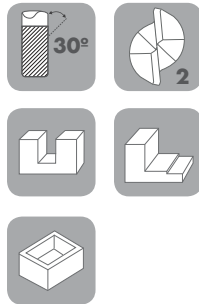

ALTiN NANO



1,5° CONICIDAD AL RÁDIO

Ref.	Dimensiones (mm)						Precio €
2 Flutes (Z2)	Dc	d	R	Lc	C	L	
H-CEM2015XL-r0,3-C43x1,5°	1,5	6	0,3	2	43	109	
H-CEM2015XL-r0,3-C53x1,5°	1,5	6	0,3	2	53	109	
H-CEM2015XL-r0,3-C63x1,5°	1,5	6	0,3	2	63	109	
H-CEM2020XL-r0,5-C43x1,5°	2	6	0,5	3	43	109	
H-CEM2020XL-r0,5-C53x1,5°	2	6	0,5	3	53	109	
H-CEM2020XL-r0,5-C63x1,5°	2	6	0,5	3	63	109	
H-CEM2030XL-r0,5-C44x1,5°	3	6	0,5	5	44	109	
H-CEM2030XL-r0,5-C55x1,5°	3	6	0,5	5	55	109	
H-CEM2030XL-r0,5-C65x1,5°	3	6	0,5	5	65	109	
H-CEM2040XL-r0,5-C45x1,5°	4	6	0,5	6	45	109	
H-CEM2040XL-r1,0-C45x1,5°	4	6	1	6	45	109	
H-CEM2050XL-r0,5-C45x1,5°	5	8	0,5	7	45	109	
H-CEM2050XL-r0,5-C55x1,5°	5	8	0,5	7	55	109	
H-CEM2050XL-r1,0-C45x1,5°	5	8	1	7	45	109	
H-CEM2050XL-r1,0-C55x1,5°	5	8	1	7	55	109	

I Z2 FRESA TÓRICA CONICA A 1,5°

EN Z2 CORNER RADIUS END MILL | 1,5° TAPER

FR Z2 FRAISE TORIQUE | 1,5°

DE Z2 TORUSFRÄSER | 1,5°



Ref.	Dimensiones (mm)						Precio €
	Dc	d	R	Lc	C	L	
2 Flutes (Z2)							
H-CEM2060XL-r0,5-C48x1,5°	6	8	0,5	9	48	109	
H-CEM2060XL-r1,0-C48x1,5°	6	8	1	9	48	109	
H-CEM2060XL-r1,5-C48x1,5°	6	8	1,5	9	48	109	
H-CEM2080XL-r0,5-C48x1,5°	8	10	0,5	10	48	109	
H-CEM2080XL-r1,0-C48x1,5°	8	10	1	10	48	109	
H-CEM2080XL-r1,5-C48x1,5°	8	10	1,5	10	48	109	
H-CEM2080XL-r2,0-C48x1,5°	8	10	2	10	48	109	

I Z4 FRESA TÓRICA CONICA A 1,5°

EN Z4 CORNER RADIUS END MILL | 1,5° TAPER

FR Z4 FRAISE TORIQUE | 1,5°

DE Z4 TORUSFRÄSER | 1,5°

ES Acero, Acero Inoxidable, Fundición Gris, Cobre, Titanio y Aceros hasta 62 HRC.

EN Steel, Stainless Steel, Cast Iron, Cooper, Titanium and Hardened Steels up to 62 HRC.

FR Acier, Acier Inoxydable, Fonte Grise, Cuivre, Titane et Acier Jusqu'à 62 HRC.

DE Stahl, Rostfreier Stahl, Gubeisen, Kupfer, Titan, Gehärteter Stahl 62 HRC.

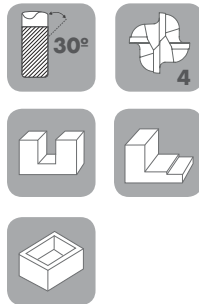

ALTIM NANO

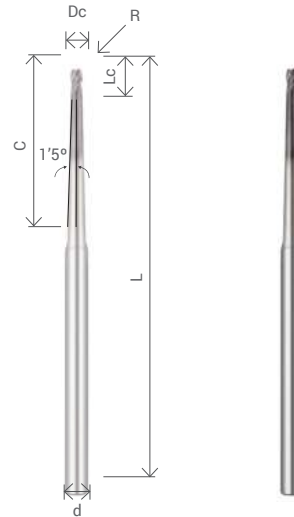

Ref.	Dimensiones (mm)						Precio €
4 Flutes (Z4)	Dc	d	R	Lc	C	L	
H-CEM4020XL-r0,5-C43x1,5°	2	6	0,5	3	43	109	
H-CEM4020XL-r0,5-C53x1,5°	2	6	0,5	3	53	109	
H-CEM4020XL-r0,5-C63x1,5°	2	6	0,5	3	63	109	
H-CEM4030XL-r0,5-C44x1,5°	3	6	0,5	5	44	109	
H-CEM4030XL-r0,5-C55x1,5°	3	6	0,5	5	55	109	
H-CEM4030XL-r0,5-C65x1,5°	3	6	0,5	5	65	109	
H-CEM4040XL-r0,5-C45x1,5°	4	6	0,5	6	45	109	
H-CEM4040XL-r1,0-C45x1,5°	4	6	1	6	45	109	
H-CEM4050XL-r0,5-C45x1,5°	5	8	0,5	7	45	109	
H-CEM4050XL-r0,5-C55x1,5°	5	8	0,5	7	55	109	
H-CEM4050XL-r1,0-C45x1,5°	5	8	1	7	45	109	
H-CEM4050XL-r1,0-C55x1,5°	5	8	1	7	55	109	
H-CEM4060XL-r0,5-C48x1,5°	6	8	0,5	9	48	109	
H-CEM4060XL-r1,0-C48x1,5°	6	8	1	9	48	109	
H-CEM4060XL-r1,5-C48x1,5°	6	8	1,5	9	48	109	
H-CEM4080XL-r0,5-C48x1,5°	8	10	0,5	10	48	109	
H-CEM4080XL-r1,0-C48x1,5°	8	10	1	10	48	109	
H-CEM4080XL-r1,5-C48x1,5°	8	10	1,5	10	48	109	
H-CEM4080XL-r2,0-C48x1,5°	8	10	2	10	48	109	



05

FRESAS de alto rendimiento y específicas

HIGH PERFORMANCE END MILLS
HAUTE PERFORMANCE
SHOCHLEISTUNGSBEARBEITUNG

I Z3 HYPERLINK: FRESA HELICE VARIABLE 35°/38° CHAFLAN EN ESQUINA / SERIE ECONÓMICA

- EN** Z3 HYPERLINK. UNEQUAL HELIX ANGLES 35°-38° | ECONOMY
FR Z3 HYPERLINK. HÉLICE DIFFÉRENTE 35°-38° | ÉCONOMIQUE
DE Z3 HYPERLINK. UNGLEICHER DRALLWINKEL 35°-38° | WIRTSCHAFTLICH

- ES** Acero, Acero Inoxidable, Fundición Gris, Cobre, Titanio, Aleaciones Resistentes al Calor y Aceros hasta 56 HRC.
- EN** Steel, Stainless Steel, Cast Iron, Cooper, Titanium, Heat Resistance Alloys and Hardened Steels up to 56 HRC.
- FR** Acier, Acier Inoxydable, Fonte Grise, Cuivre, Titane, Alliages de Résistance à la Chaleur et Acier Jusq'ua 56 HRC.
- DE** Stahl, Rostfreier Stahl, Gubeisen, Kupfer, Titan, Warmfeste Legierungen und Gehärteter Stahl 56 HRC.

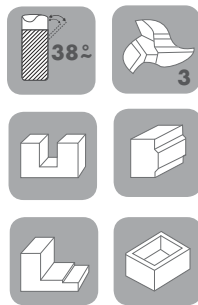

ALTIN TITAN

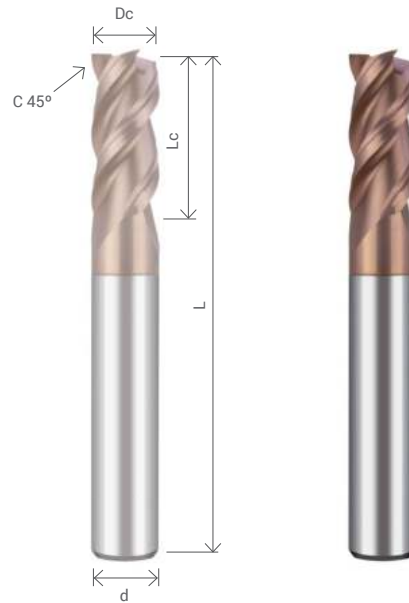

HELICE 35°/38°

Ref.	Dimensiones (mm)					Precio €
	Dc	d	LC	C-45°	L	
3 Flutes (Z3)						
HYP-3030R	3	6	8	0,05	50	
HYP-3040R	4	6	11	0,06	50	
HYP-3050R	5	6	13	0,07	50	
HYP-3060R	6	6	16	0,10	50	
HYP-3080R	8	8	19	0,15	60	
HYP-3100R	10	10	22	0,15	73	
HYP-3120R	12	12	26	0,25	75	
HYP-3140R	14	14	30	0,30	85	
HYP-3160R	16	16	32	0,35	92	
HYP-3180R	18	18	38	0,35	92	
HYP-3200R	20	20	38	0,35	100	

Z4 HYPERLINK: FRESA HELICE VARIABLE 35°/38° CHAFLAN EN ESQUINA / SERIE ECONÓMICA

EN Z4 HYPERLINK. UNEQUAL HELIX ANGLES 35°-38° | ECONOMY

FR Z4 HYPERLINK. HÉLICE DIFFÉRENTE 35°-38° | ÉCONOMIQUE

DE Z4 HYPERLINK. UNGLEICHER DRALLWINKEL 35°-38° | WIRTSCHAFTLICH

ES Acero, Acero Inoxidable, Fundición Gris, Cobre, Titanio, Aleaciones Resistentes al Calor y Aceros hasta 56 HRC.

EN Steel, Stainless Steel, Cast Iron, Cooper, Titanium, Heat Resistance Alloys and Hardened Steels up to 56 HRC.

FR Acier, Acier Inoxydable, Fonte Grise, Cuivre, Titane, Alliages de Résistance à la Chaleur et Acier Jusq'ua 56 HRC.

DE Stahl, Rostfreier Stahl, Gubeisen, Kupfer, Titan, Warmfeste Legierungen und Gehärteter Stahl 56 HRC.

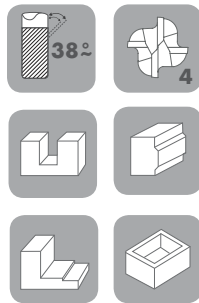

ALTIN TITAN

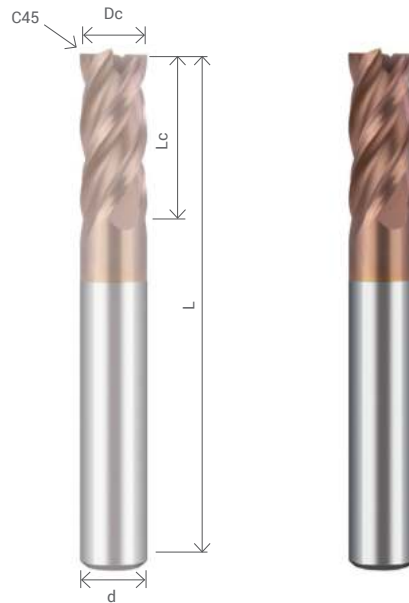

HELICE 35°/38°

Ref.	Dimensiones (mm)					Precio €
	Dc	d	LC	C-45°	L	
HYP-4030R	3	6	8	0,05	50	
HYP-4040R	4	6	11	0,06	50	
HYP-4050R	5	6	13	0,07	50	
HYP-4060R	6	6	16	0,10	50	
HYP-4080R	8	8	19	0,15	60	
HYP-4100R	10	10	22	0,15	73	
HYP-4120R	12	12	26	0,25	75	
HYP-4140R	14	14	30	0,30	85	
HYP-4160R	16	16	32	0,35	92	
HYP-4180R	18	18	38	0,35	92	
HYP-4200R	20	20	38	0,35	100	

I Z4 HYPERLINK: FRESA HELICE VARIABLE 35°/38° WELDOM

CHAFLAN EN ESQUINA / MANGO WELDOM DIN6535 / SERIE ECONÓMICA

EN Z4 HYPERLINK. UNEQUAL HELIX ANGLES 35°-38° | WELDOM DIN6535 | ECONOMY

FR Z4 HYPERLINK. HÉLICE DIFFÉRENTE 35°-38° | WELDOM DIN6535 | ÉCONOMIQUE

DE Z4 HYPERLINK. UNGLEICHER DRALLWINKEL 35°-38° | WELDOM DIN6535 | WIRTSCHAFTLICH

ES Acero, Acero Inoxidable, Fundición Gris, Cobre, Titanio, Aleaciones Resistentes al Calor y Aceros hasta 56 HRC.

EN Steel, Stainless Steel, Cast Iron, Cooper, Titanium, Heat Resistance Alloys and Hardened Steels up to 56 HRC.

FR Acier, Acier Inoxydable, Fonte Grise, Cuivre, Titane, Alliages de Résistance à la Chaleur et Acier Jusq'ua 56 HRC.

DE Stahl, Rostfreier Stahl, Gubeisen, Kupfer, Titan, Warmfeste Legierungen und Gehärteter Stahl 56 HRC.

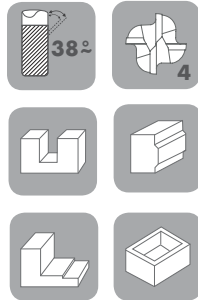

ALTIN TITAN

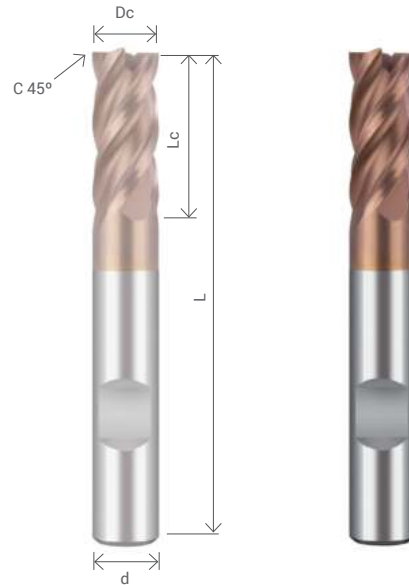

MANGO WELDOM HELICE 35°/38°

Ref.	Dimensiones (mm)					Precio €
	Dc	d	Lc	C-45°	L	
4 Flutes (Z4)						
HYP-4030RW	3	6	8	0,05	57	
HYP-4040RW	4	6	11	0,06	57	
HYP-4050RW	5	6	13	0,07	57	
HYP-4060RW	6	6	16	0,10	57	
HYP-4080RW	8	8	19	0,15	63	
HYP-4100RW	10	10	22	0,15	73	
HYP-4120RW	12	12	26	0,25	84	
HYP-4140RW	14	14	30	0,30	85	
HYP-4160RW	16	16	32	0,35	92	
HYP-4200RW	20	20	38	0,35	104	

Z4 HYPERLINK: FRESA HELICE VARIABLE 35°/38° Medidas Especiales CHAFLAN EN ESQUINA / SERIE ECONÓMICA

EN Z4 HYPERLINK. UNEQUAL HELIX ANGLES 35°-38° | SPECIAL SIZES | ECONOMY

FR Z4 HYPERLINK. HÉLICE DIFFÉRENTE 35°-38° | SPECIAL MEASURES | ÉCONOMIQUE

DE Z4 HYPERLINK. UNGLEICHER DRALLWINKEL 35°-38° | SPECIAL MEASURES | WIRTSCHAFTLICH

ES Acero, Acero Inoxidable, Fundición Gris, Cobre, Titanio, Aleaciones Resistentes al Calor y Aceros hasta 56 HRC.

EN Steel, Stainless Steel, Cast Iron, Cooper, Titanium, Heat Resistance Alloys and Hardened Steels up to 56 HRC.

FR Acier, Acier Inoxydable, Fonte Grise, Cuivre, Titane, Alliages de Résistance à la Chaleur et Acier Jusqu'à 56 HRC.

DE Stahl, Rostfreier Stahl, Gubeisen, Kupfer, Titan, Warmfeste Legierungen und Gehärteter Stahl 56 HRC.

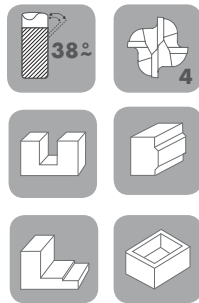

ALTIN TITAN



MEDIDAS ESPECIALES HELICE 35°/38°

Ref.	Dimensiones (mm)					Precio €
	Dc	d	Lc	C-45°	L	
4 Flutes (Z4)						
HYP-4100-25R	10	10	25	0,15	73	
HYP-4120L-35R	12	12	35	0,25	83	
HYP-4160-45R	16	16	45	0,35	100	
HYP-4160-52R	16	16	52	0,35	108	
HYP-4160-65R	16	16	65	0,35	150	
HYP-4200-55R	20	20	55	0,35	104	
HYP-4200-70R	20	20	70	0,35	150	

I Z4 HYPERLINK: F. H. V. 35°/38° Cuello Rebajado. Económica CHAFLAN EN ESQUINA

EN Z4 HYPERLINK. UNEQUAL HELIX ANGLES 35°-38° | REDUCED NECK | ECONOMY

FR Z4 HYPERLINK. HÉLICE DIFFÉRENTE 35°-38° | ÉCONOMIQUE

DE Z4 HYPERLINK. UNGLEICHER DRALLWINKEL 35°-38° | WIRTSCHAFTLICH

ES Acero, Acero Inoxidable, Fundición Gris, Cobre, Titanio y Aceros hasta 56 HRC.

EN Steel, Stainless Steel, Cast Iron, Cooper, Titanium and Hardened Steels up to 56 HRC.

FR Acier, Acier Inoxydable, Fonte Grise, Cuivre, Titane et Acier Jusqu'à 56 HRC.

DE Stahl, Rostfreier Stahl, Gubeisen, Kupfer, Titan und Gehärteter Stahl 56 HRC.

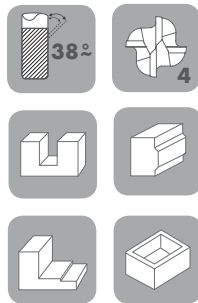

ALTiN NANO



CUELLO REBAJADO. HELICE 35°/38°

Ref.	Dimensiones (mm)						Precio €
	Dc	d	Lc	U	C-45°	L	
4 Flutes (Z4)							
HYP-4030U10H	3	6	8	10	0,05	57	
HYP-4030U20H	3	6	8	20	0,05	57	
HYP-4040U13H	4	6	11	13	0,06	57	
HYP-4040U20H	4	6	11	20	0,06	57	
HYP-4050U16H	5	6	13	16	0,07	57	
HYP-4050U21H	5	6	13	21	0,07	57	
HYP-4060U21H	6	6	13	21	0,10	57	
HYP-4080U27H	8	8	19	27	0,15	63	
HYP-4100U32H	10	10	22	32	0,15	73	
HYP-4120U38H	12	12	26	38	0,25	83	
HYP-4140U40H	14	14	30	40	0,30	84	
HYP-4160U44H	16	16	32	44	0,35	92	
HYP-4200U55H	20	20	38	55	0,35	104	

Z4 HYPERLINK: F. H. V. 35°/38° Cuello Rebajado WELDOM Econ. CHAFLAN EN ESQUINA

- EN** Z4 HYPERLINK. UNEQUAL HELIX ANGLES 35°-38° | WELDOM DIN6535 | REDUCED NECK | ECONOMY
FR Z4 HYPERLINK. HÉLICE DIFFÉRENTE 35°-38° | WELDOM DIN6535 | ECONOMY
DE Z4 HYPERLINK. UNGLEICHER DRALLWINKEL 35°-38° | WELDOM DIN6535

ES Acero, Acero Inoxidable, Fundición Gris, Cobre, Titanio y Aceros hasta 56 HRC.

EN Steel, Stainless Steel, Cast Iron, Cooper, Titanium and Hardened Steels up to 56 HRC.

FR Acier, Acier Inoxydable, Fonte Grise, Cuivre, Titane et Acier Jusq'ua 56 HRC.

DE Stahl, Rostfreier Stahl, Gubeisen, Kupfer, Titan und Gehärteter Stahl 56 HRC.

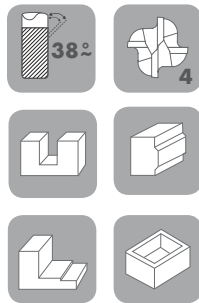

ALTIN NANO



SHANK: DIN6535HB. HELICE 35°/38°

Ref.	Dimensiones (mm)						Precio €
	Dc	d	Lc	U	C-45°	L	
4 Flutes (Z4)							
HYP-4030U20HW	3	6	8	20	0,05	57	
HYP-4040U20HW	4	6	11	20	0,06	57	
HYP-4050U21HW	5	6	13	21	0,07	57	
HYP-4060U21HW	6	6	13	21	0,10	57	
HYP-4080U27HW	8	8	19	27	0,15	63	
HYP-4100U32HW	10	10	22	32	0,15	73	
HYP-4120U38HW	12	12	26	38	0,25	83	
HYP-4140U40HW	14	14	30	40	0,30	84	
HYP-4160U44HW	16	16	32	44	0,35	92	
HYP-4200U55HW	20	20	38	55	0,35	104	

I Z4 HYPERLINK PLUS: FRESA HELICE VARIABLE Cuello Rebajado MULTIUSOS / HELICE VARIABLE 35°/38° / CALIDAD PREMIUM

- EN** Z4 HYPERLINK PLUS: UNEQUAL HELIX ANGLES 35°-38° | MULTIPURPOSE | REDUCED NECK | PREMIUM
FR Z4 HYPERLINK PLUS: HÉLICE DIFFÉRENTE 35°-38° | PREMIUM
DE Z4 HYPERLINK PLUS: UNGLEICHER DRALLWINKEL 35°-38° | PREMIUM

ES Acero, Acero Inoxidable, Fundición Gris, Cobre, Titanio, Aleaciones Resistentes al Calor y Aceros hasta 56 HRC.

EN Steel, Stainless Steel, Cast Iron, Cooper, Titanium, Heat Resistance Alloys and Hardened Steels up to 56 HRC.

FR Acier, Acier Inoxydable, Fonte Grise, Cuivre, Titane, Alliages de Résistance à la Chaleur et Acier Jusq'ua 56 HRC.

DE Stahl, Rostfreier Stahl, Gubeisen, Kupfer, Titan, Warmfeste Legierungen und Gehärteter Stahl 56 HRC.

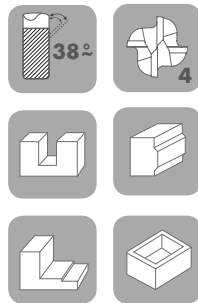

ALCrN



CUELLO REBAJADO. HELICE 35°/38°

Ref.	Dimensiones (mm)						Precio €
	Dc	d	Lc	U	C-45°	L	
4 Flutes (Z4)							
HYP-4030U20PB	3	6	8	20	0,05	57	
HYP-4040U20PB	4	6	11	20	0,06	57	
HYP-4050U21PB	5	6	13	21	0,07	57	
HYP-4060U21PB	6	6	13	21	0,10	57	
HYP-4080U27PB	8	8	19	27	0,15	63	
HYP-4100U32PB	10	10	22	32	0,15	73	
HYP-4120U38PB	12	12	26	38	0,25	83	
HYP-4140U40PB	14	14	30	40	0,30	84	
HYP-4160U44PB	16	16	32	44	0,35	92	
HYP-4200U55PB	20	20	38	55	0,35	104	

Z4 HYPERLINK PLUS: FRESA H. V. WELDOM Cuello Rebajado

MULTIUSOS / HELICE VARIABLE 35°/38° / WELDOM DIN6535 / PREMIUM

EN Z4 HYPERLINK PLUS. UNEQUAL HELIX ANGLES 35°-38° | WELDOM DIN6535 | MULTIPURPOSE | PREMIUM

FR Z4 HYPERLINK PLUS. HÉLICE DIFFÉRENTE 35°-38° | WELDOM DIN6535 | PREMIUM

DE Z4 HYPERLINK PLUS. UNGLEICHER DRALLWINKEL 35°-38° | WELDOM | PREMIUM

ES Acero, Acero Inoxidable, Fundición Gris, Cobre, Titanio, Aleaciones Resistentes al Calor y Aceros hasta 56 HRC.

EN Steel, Stainless Steel, Cast Iron, Cooper, Titanium, Heat Resistance Alloys and Hardened Steels up to 56 HRC.

FR Acier, Acier Inoxydable, Fonte Grise, Cuivre, Titane, Alliages de Résistance à la Chaleur et Acier Jusq'ua 56 HRC.

DE Stahl, Rostfreier Stahl, Gubeisen, Kupfer, Titan, Warmfeste Legierungen und Gehärteter Stahl 56 HRC.

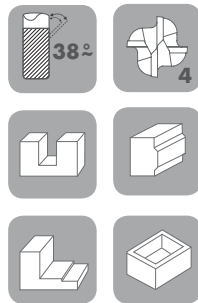

ALCrN



CUELLO REBAJADO. SHANK: DIN6535HB. 35°/38°

Ref.	Dimensiones (mm)						Precio €
	Dc	d	Lc	U	C-45°	L	
HYP-4030U20PBW	3	6	8	20	0,05	57	
HYP-4040U20PBW	4	6	11	20	0,06	57	
HYP-4050U21PBW	5	6	13	21	0,07	57	
HYP-4060U21PBW	6	6	13	21	0,10	57	
HYP-4080U27PBW	8	8	19	27	0,15	63	
HYP-4100U32PBW	10	10	22	32	0,15	73	
HYP-4120U38PBW	12	12	26	38	0,25	83	
HYP-4140U40PBW	14	14	30	40	0,30	84	
HYP-4160U44PBW	16	16	32	44	0,35	92	
HYP-4200U55PBW	20	20	38	55	0,35	104	

Z4 HYRUX: FRESA HELICE VARIABLE 43°/45° Alto Rendimiento CHAFLAN EN ESQUINA /MULTIUSOS / CALIDAD PREMIUM

- EN** Z4 HYRUX: UNEQUAL HELIX ANGLES 43-45° | MULTIPURPOSE | HIGH PERFORMANCE
FR Z4 HYRUX: HÉLICE DIFFÉRENTE 43-45° | HAUTE PERFORMANCE
DE Z4 HYRUX: UNGLEICHER DRALLWINKEL 43-45° | HOCHLEISTUNGSBEARBEITUNG

ES Acero, Acero Inoxidable, Fundición Gris, Cobre, Titanio, Aleaciones Resistentes al Calor y Aceros hasta 56 HRC.

EN Steel, Stainless Steel, Cast Iron, Cooper, Titanium, Heat Resistance Alloys and Hardened Steels up to 56 HRC.

FR Acier, Acier Inoxydable, Fonte Grise, Cuivre, Titane, Alliages de Résistance à la Chaleur et Acier Jusq'ua 56 HRC.

DE Stahl, Rostfreier Stahl, Gubeisen, Kupfer, Titan, Warmfeste Legierungen und Gehärteter Stahl 56 HRC.

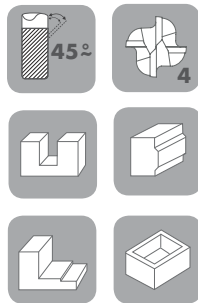

ALCrN

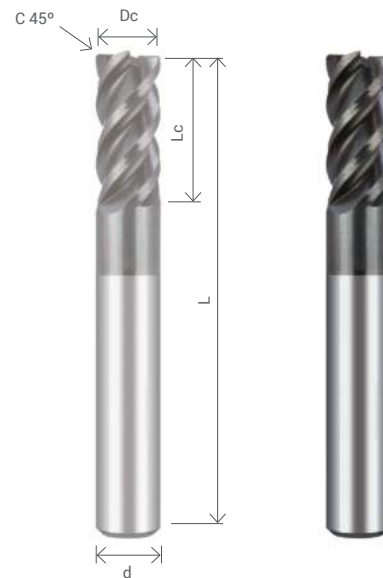

ALTO RENDIMIENTO

Ref.	Dimensiones (mm)					Precio €
	Dc	d	Lc	C-45°	L	
4 Flutes (Z4)						
HYRUX-4060B	6	6	13	0,2	57	
HYRUX-4080B	8	8	19	0,25	63	
HYRUX-4100B	10	10	22	0,35	73	
HYRUX-4120B	12	12	26	0,35	83	
HYRUX-4140B	14	14	30	0,4	84	
HYRUX-4160B	16	16	32	0,5	92	
HYRUX-4200B	20	20	38	0,5	104	

Z4 HYRUX: FRESA H. VARIABLE 43°/45° WELDOM Alto Rendimiento CHAFLAN EN ESQUINA / MULTIUSOS / WELDOM DIN6535 / PREMIUM

- EN** Z4 HYRUX. UNEQUAL HELIX ANGLES 43-45° | WELDOM | MULTIPURPOSE | HIGH PERFORMANCE
FR Z4 HYRUX. HÉLICE DIFFÉRENTE 43-45° | WELDOM | HAUTE PERFORMANCE
DE Z4 HYRUX. U. DRALLWINKEL 43-45° | WELDOM | HOCHLEISTUNGSBEARBEITUNG

ES Acero, Acero Inoxidable, Fundición Gris, Cobre, Titanio, Aleaciones Resistentes al Calor y Aceros hasta 56 HRC.

EN Steel, Stainless Steel, Cast Iron, Cooper, Titanium, Heat Resistance Alloys and Hardened Steels up to 56 HRC.

FR Acier, Acier Inoxydable, Fonte Grise, Cuivre, Titane, Alliages de Résistance à la Chaleur et Acier Jusq'ua 56 HRC.

DE Stahl, Rostfreier Stahl, Gubeisen, Kupfer, Titan, Warmfeste Legierungen und Gehärteter Stahl 56 HRC.

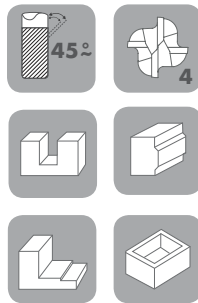

ALCrN



ALTO RENDIMIENTO. WELDOM DIN6535.

Ref.	Dimensiones (mm)					Precio €
	Dc	d	Lc	C-45°	L	
4 Flutes (Z4)						
HYRUX-4060BW	6	6	13	0,2	57	
HYRUX-4080BW	8	8	19	0,25	63	
HYRUX-4100BW	10	10	22	0,35	73	
HYRUX-4120BW	12	12	26	0,35	83	
HYRUX-4140BW	14	14	30	0,4	84	
HYRUX-4160BW	16	16	32	0,5	92	
HYRUX-4200BW	20	20	38	0,5	104	

I Z4 HYRUX: FRESA H. V. 43°/45° Cuello Rebajado. Alto Rendimiento CHAFLAN EN ESQUINA /MULTIUSOS

- EN** Z4 HYRUX: UNEQUAL HELIX ANGLES 43-45° | MULTIPURPOSE | R. NECK | HIGH PERFORMANCE
FR Z4 HYRUX: HÉLICE DIFFÉRENTE 43-45° | HAUTE PERFORMANCE
DE Z4 HYRUX: UNGLEICHER DRALLWINKEL 43-45° | SHOCHLEISTUNGSBEARBEITUNG

ES Acero, Acero Inoxidable, Fundición Gris, Cobre, Titanio, Aleaciones Resistentes al Calor y Aceros hasta 56 HRC.

EN Steel, Stainless Steel, Cast Iron, Cooper, Titanium, Heat Resistance Alloys and Hardened Steels up to 56 HRC.

FR Acier, Acier Inoxydable, Fonte Grise, Cuivre, Titane, Alliages de Résistance à la Chaleur et Acier Jusq'ua 56 HRC.

DE Stahl, Rostfreier Stahl, Gubeisen, Kupfer, Titan, Warmfeste Legierungen und Gehärteter Stahl 56 HRC.

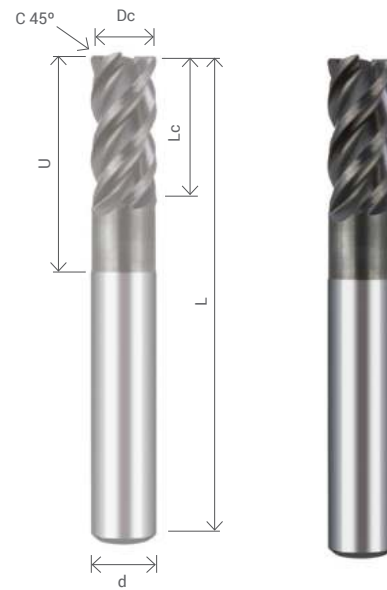
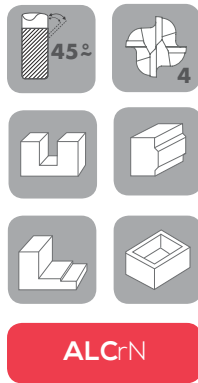

ALTO RENDIMIENTO

Ref.	Dimensiones (mm)						Precio €
	Dc	d	Lc	U	C-45°	L	
4 Flutes (Z4)							
HYRUX-4030U11B	3	6	8	11	0,07	57	
HYRUX-4030U20B	3	6	8	20	0,07	57	
HYRUX-4040U14B	4	6	11	14	0,09	57	
HYRUX-4040U20B	4	6	11	20	0,09	57	
HYRUX-4050U16B	5	6	13	16	0,12	57	
HYRUX-4050U21B	5	6	13	21	0,12	57	
HYRUX-4060U21B	6	6	13	21	0,2	57	
HYRUX-4080U27B	8	8	19	27	0,25	63	
HYRUX-4100U32B	10	10	22	32	0,35	73	
HYRUX-4120U38B	12	12	26	38	0,35	83	
HYRUX-4140U40B	14	14	30	40	0,4	84	
HYRUX-4160U44B	16	16	32	44	0,5	92	
HYRUX-4200U55B	20	20	38	55	0,5	104	

Z4 HYRUX: F.H.V. 43°/45° Cuello Rebajado WELDOM Alto Rendimien. CHAFLAN EN ESQUINA / MULTIUSOS / WELDOM DIN6535

EN Z4 HYRUX. UNEQUAL HELIX ANGLES 43-45° | WELDOM | MULTIPURPOSE | R. NECK | HIGH PERFORMANCE
FR Z4 HYRUX. HÉLICE DIFFÉRENTE 43-45° | WELDOM | HAUTE PERFORMANCE
DE Z4 HYRUX. UNGLEICHER DRALLWINKEL 43-45° | WELDOM | SHOCHLEISTUNGSBEARBEITUNG

ES Acero, Acero Inoxidable, Fundición Gris, Cobre, Titanio, Aleaciones Resistentes al Calor y Aceros hasta 56 HRC.

EN Steel, Stainless Steel, Cast Iron, Cooper, Titanium, Heat Resistance Alloys and Hardened Steels up to 56 HRC.

FR Acier, Acier Inoxydable, Fonte Grise, Cuivre, Titane, Alliages de Résistance à la Chaleur et Acier Jusq'ua 56 HRC.

DE Stahl, Rostfreier Stahl, Gubeisen, Kupfer, Titan, Warmfeste Legierungen und Gehärteter Stahl 56 HRC.

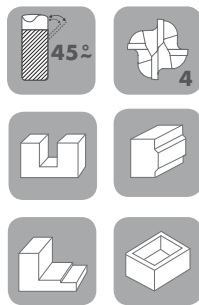

ALCrN



ALTO RENDIMIENTO. WELDOM DIN6535.

Ref.	Dimensiones (mm)						Precio €
	Dc	d	Lc	U	C-45°	L	
4 Flutes (Z4)							
HYRUX-4030U11BW	3	6	8	11	0,07	57	
HYRUX-4030U20BW	3	6	8	20	0,07	57	
HYRUX-4040U14BW	4	6	11	14	0,09	57	
HYRUX-4040U20BW	4	6	11	20	0,09	57	
HYRUX-4050U16BW	5	6	13	16	0,12	57	
HYRUX-4050U21BW	5	6	13	21	0,12	57	
HYRUX-4060U21BW	6	6	13	21	0,2	57	
HYRUX-4080U27BW	8	8	19	27	0,25	63	
HYRUX-4100U32BW	10	10	22	32	0,35	73	
HYRUX-4120U38BW	12	12	26	38	0,35	83	
HYRUX-4140U40BW	14	14	30	40	0,4	84	
HYRUX-4160U44BW	16	16	32	44	0,5	92	
HYRUX-4200U55BW	20	20	38	55	0,5	104	

I Z4 HYRUX TITANIO: FRESA HELICE VARIABLE 43°/45° CHAFLAN EN ESQUINA / ALTO RENDIMIENTO

- EN** Z4 HYRUX TITANIUM: UNEQUAL HELIX ANGLES 43-45° | HIGH PERFORMANCE
FR Z4 HYRUX TITANIUM: HÉLICE DIFFÉRENTE 43-45° | DE HAUTE PERFORMANCE
DE Z4 HYRUX TITANIUM: UNGLEICHER DRALLWINKEL 43-45° | HOCHLEISTUNGSBEARBEITUNG

- ES** Acero Inoxidable, Titanio, Aleaciones Titanio y Aleaciones Resistentes al Calor.
EN Stainless Steel, Titanium, Titanium Alloys and Heat Resistance Alloys.
FR Acier Inoxydable, Alliages de Titanie, Titane, Alliages de et Résistance à la Chaleur.
DE Rostfreier Stahl, Titan, Warmfeste und Legierungen.

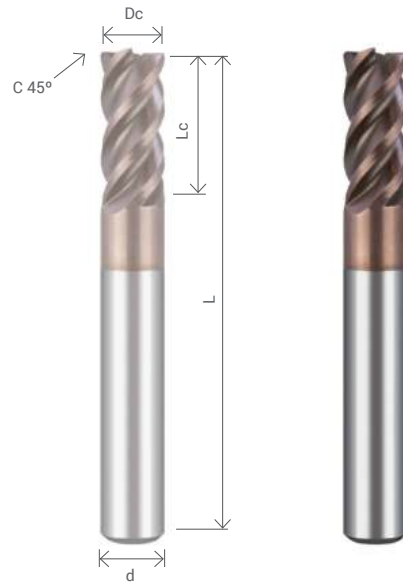
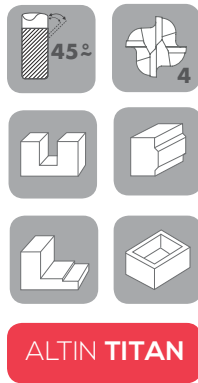

ESPECIAL TITANIO Y ALEACIONES NICKEL

Ref.	Dimensiones (mm)					Precio €
	Dc	d	Lc	C-45°	L	
4 Flutes (Z4)						
HYRUX-4060R	6	6	13	0,2	57	
HYRUX-4080R	8	8	19	0,25	63	
HYRUX-4100R	10	10	22	0,35	73	
HYRUX-4120R	12	12	26	0,35	83	
HYRUX-4140R	14	14	30	0,4	84	
HYRUX-4160R	16	16	32	0,5	92	
HYRUX-4200R	20	20	38	0,5	104	

Z4 HYRUX TITANIO: FRESA HELICE VARIABLE 43°/45° WELDOM CHAFLAN EN ESQUINA / WELDOM DIN6535 / ALTO RENDIMIENTO

- EN** Z4 HYRUX TITANIUM. UNEQUAL HELIX ANGLES 43-45° | WELDOM DIN6535 | HIGH PERFORMANCE
FR Z4 HYRUX TITANIUM. HÉLICE DIFFÉRENTE 43-45° | WELDOM DIN6535 | DE HAUTE PERFORMANCE
DE Z4 HYRUX TITANIUM. UNGLEICHER DRALLWINKEL 43-45° | W. DIN6535 | HOCHLEISTUNGSBEARBEITUNG

- ES** Acero Inoxidable, Titanio, Aleaciones Titanio y Aleaciones Resistentes al Calor.
EN Stainless Steel, Titanium, Titanium Alloys and Heat Resistance Alloys.
FR Acier Inoxydable, Alliages de Titanie, Titane, Alliages de et Résistance à la Chaleur.
DE Rostfreier Stahl, Titan, Warmfeste und Legierungen.

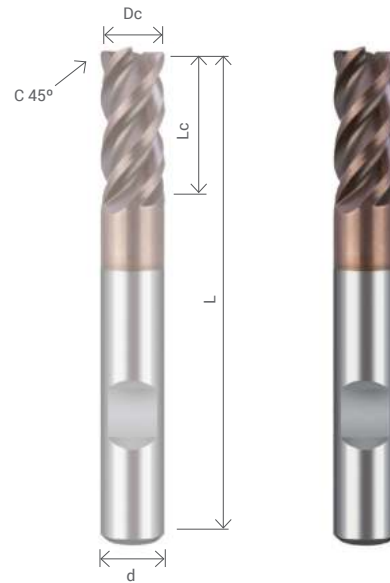
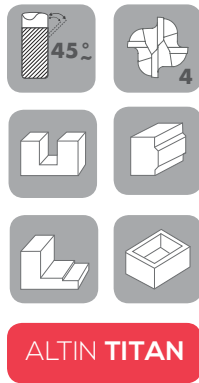

ESPECIAL TITANIO Y ALEACIONES NICKEL. WELDOM DIN6535

Ref.	Dimensiones (mm)					Precio €
	Dc	d	Lc	C-45°	L	
4 Flutes (Z4)						
HYRUX-4060RW	6	6	13	0,2	57	
HYRUX-4080RW	8	8	19	0,25	63	
HYRUX-4100RW	10	10	22	0,35	73	
HYRUX-4120RW	12	12	26	0,35	83	
HYRUX-4140RW	14	14	30	0,4	84	
HYRUX-4160RW	16	16	32	0,5	92	
HYRUX-4200RW	20	20	38	0,5	104	

I Z4 HYRUX TITANIO: FRESA H. V. 43°/45° Cuello Rebajado CHAFLAN EN ESQUINA / PREMIUM / ALTO RENDIMIENTO

- EN** Z4 HYRUX TITANIUM: UNEQUAL HELIX ANGLES 43-45° | REDUCED NECK | HIGH PERFORMANCE
FR Z4 HYRUX TITANIUM: HÉLICE DIFFÉRENTE 43-45° | DE HAUTE PERFORMANCE
DE Z4 HYRUX TITANIUM: UNGLEICHER DRALLWINKEL 43-45° | HOCHLEISTUNGSBEARBEITUNG

- ES** Acero Inoxidable, Titanio, Aleaciones Titanio y Aleaciones Resistentes al Calor.
EN Stainless Steel, Titanium, Titanium Alloys and Heat Resistance Alloys.
FR Acier Inoxydable, Alliages de Titane, Titane, Alliages de et Résistance à la Chaleur.
DE Rostfreier Stahl, Titan, Warmfeste und Legierungen.

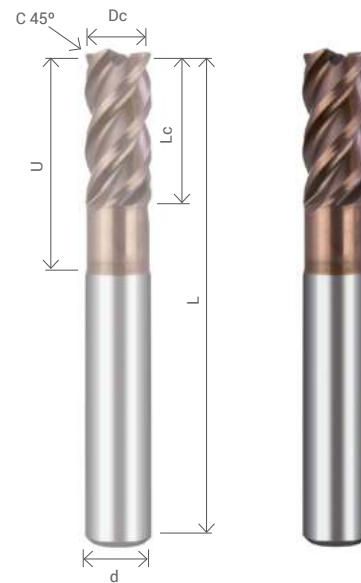
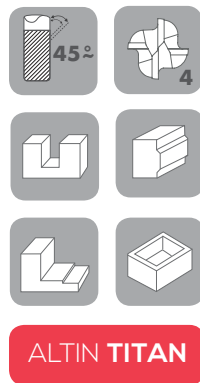

ESPECIAL TITANIO Y ALEACIONES NICKEL

Ref.	Dimensiones (mm)						Precio €
	Dc	d	Lc	U	C-45°	L	
4 Flutes (Z4)							
HYRUX-4030U11R	3	6	8	11	0,07	57	
HYRUX-4030U20R	3	6	8	20	0,07	57	
HYRUX-4040U14R	4	6	11	14	0,09	57	
HYRUX-4040U20R	4	6	11	20	0,09	57	
HYRUX-4050U16R	5	6	13	16	0,12	57	
HYRUX-4050U21R	5	6	13	21	0,12	57	
HYRUX-4060U21R	6	6	13	21	0,2	57	
HYRUX-4080U27R	8	8	19	27	0,25	63	
HYRUX-4100U32R	10	10	22	32	0,35	73	
HYRUX-4120U38R	12	12	26	38	0,35	83	
HYRUX-4140U40R	14	14	30	40	0,4	84	
HYRUX-4160U44R	16	16	32	44	0,5	92	
HYRUX-4200U55R	20	20	38	55	0,5	104	

Z4 HYRUX TITANIO: FRESA H. V. 43°/45° Cuello Rebajado WELDOM CHAFLAN EN ESQUINA / WELDOM DIN6535 / ALTO RENDIMIENTO

- EN** Z4 HYRUX TITANIUM: UNEQUAL HELIX ANGLES 43-45° | W. DIN6535 | R. NECK | HIGH PERFORMANCE
FR Z4 HYRUX TITANIUM: HÉLICE DIFFÉRENTE 43-45° | W. DIN6535 | DE HAUTE PERFORMANCE
DE Z4 HYRUX TITANIUM: UNGLEICHER DRALLWINKEL 43-45° | HOCHLEISTUNGSBEARBEITUNG

- ES** Acero Inoxidable, Titanio, Aleaciones Titanio y Aleaciones Resistentes al Calor.
EN Stainless Steel, Titanium, Titanium Alloys and Heat Resistance Alloys.
FR Acier Inoxydable, Alliages de Titane, Titane, Alliages de et Résistance à la Chaleur.
DE Rostfreier Stahl, Titan, Warmfeste und Legierungen.

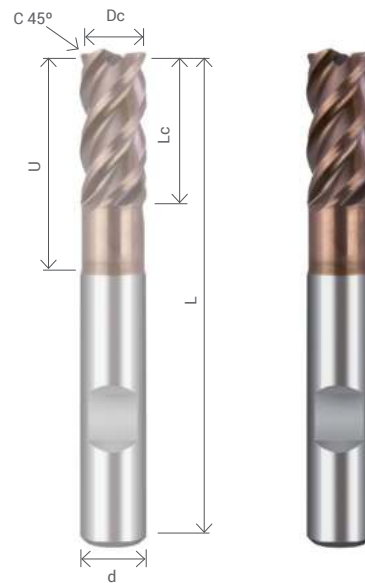
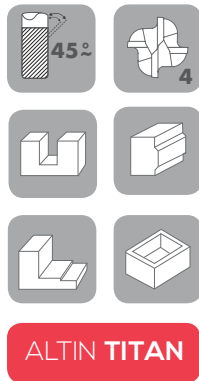

ESPECIAL TITANIO Y ALEACIONES NICKEL. WELDOM DIN6535

Ref.	Dimensiones (mm)						Precio €
	Dc	d	Lc	U	C-45°	L	
4 Flutes (Z4)							
HYRUX-4030U11RW	3	6	8	11	0,07	57	
HYRUX-4030U20RW	3	6	8	20	0,07	57	
HYRUX-4040U14RW	4	6	11	14	0,09	57	
HYRUX-4040U20RW	4	6	11	20	0,09	57	
HYRUX-4050U16RW	5	6	13	16	0,12	57	
HYRUX-4050U21RW	5	6	13	21	0,12	57	
HYRUX-4060U21RW	6	6	13	21	0,2	57	
HYRUX-4080U27RW	8	8	19	27	0,25	63	
HYRUX-4100U32RW	10	10	22	32	0,35	73	
HYRUX-4120U38RW	12	12	26	38	0,35	83	
HYRUX-4140U40RW	14	14	30	40	0,4	84	
HYRUX-4160U44RW	16	16	32	44	0,5	92	
HYRUX-4200U55RW	20	20	38	55	0,5	104	

I Z5 HELIX: FRESA H.V. 43°/45° Cuello Rebajado 1°. Chaflán <55HRC CHAFLAN EN ESQUINA / ALTO RENDIMIENTO / MULTIUSO

- EN** Z5 HELIX: UNEQUAL HELIX ANGLES 43-45° | REDUCED NECK | MULTIURPOSE | HIGH PERFORMANCE
FR Z5 HELIX: HÉLICE DIFFÉRENTE 43-45° | DE HAUTE PERFORMANCE
DE Z5 HELIX: U. DRALLWINKEL 43-45° | HOCHLEISTUNGSBEARBEITUNG

ES Acero, Acero Inoxidable, Fundición Gris, Cobre, Titanio, Aleaciones Resistentes al Calor y Aceros hasta 56 HRC.

EN Steel, Stainless Steel, Cast Iron, Cooper, Titanium, Heat Resistance Alloys and Hardened Steels up to 56 HRC.

FR Acier, Acier Inoxydable, Fonte Grise, Cuivre, Titane, Alliages de Résistance à la Chaleur et Acier Jusq'ua 56 HRC.

DE Stahl, Rostfreier Stahl, Gubeisen, Kupfer, Titan, Warmfeste Legierungen und Gehärteter Stahl 56 HRC.

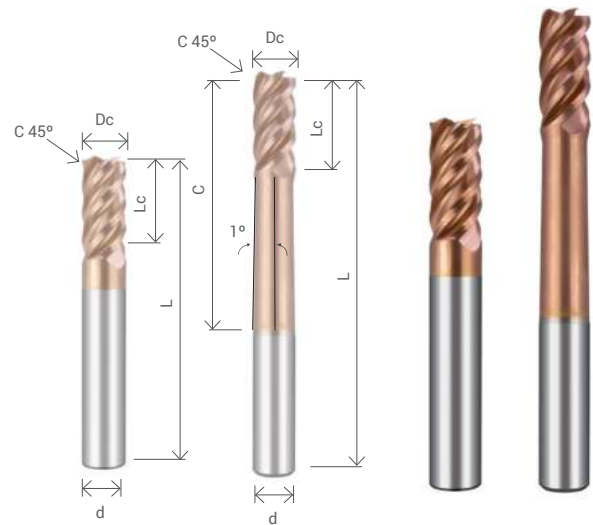
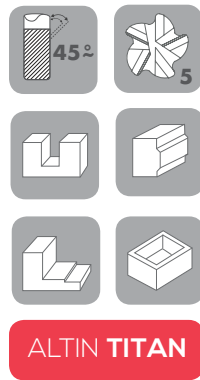

CUELLO REBAJADO A 1°

Ref.	Dimensiones (mm)						Precio €
	Dc	d	Lc	C	C-45°	L	
5 Flutes (Z5)							
HELIX-06K01-C	6	6	14	-	0,1	53	
HELIX-06K01-M	6	6	14	32	0,1	65	
HELIX-06K01-L	6	6	14	42	0,1	75	
HELIX-06K01-LL	6	6	14	51	0,1	81	
HELIX-08K01-C	8	8	18	-	0,1	60	
HELIX-08K01-M	8	8	18	42	0,1	75	
HELIX-08K01-L	8	8	18	58	0,1	90	
HELIX-08K01-LL	8	8	18	71	0,1	109	
HELIX-10K015-C	10	10	22	-	0,15	65	
HELIX-10K015-M	10	10	22	51	0,15	81	
HELIX-10K015-L	10	10	22	71	0,15	109	
HELIX-10K015-LL	10	10	22	82	0,15	109	
HELIX-12K02-C	12	12	26	-	0,2	81	
HELIX-12K02-M	12	12	26	51	0,2	81	
HELIX-12K02-L	12	12	26	71	0,2	109	
HELIX-12K02-LL	12	12	26	86	0,2	117	

Z5 HELIX: FRESA H.V. 43°/45° Cuello Rebajado 1°. Chaflán <55HRC CHAFLAN EN ESQUINA / ALTO RENDIMIENTO / MULTIUSO

- EN** Z5 HELIX: UNEQUAL HELIX ANGLES 43-45° | REDUCED NECK | MULTIURPOSE | HIGH PERFORMANCE
FR Z5 HELIX: HÉLICE DIFFÉRENTE 43-45° | DE HAUTE PERFORMANCE
DE Z5 HELIX: U. DRALLWINKEL 43-45° | HOCHLEISTUNGSBEARBEITUNG



Ref.	Dimensiones (mm)						Precio €
	Dc	d	Lc	C	C-45°	L	
5 Flutes (Z5)							
HELIX-16K02-C	16	16	38	-	0,2	81	
HELIX-16K02-M	16	16	38	61	0,2	109	
HELIX-16K02-L	16	16	38	76	0,2	109	
HELIX-16K02-LL	16	16	38	101	0,2	150	
HELIX-20K02-C	20	20	45	-	0,2	100	
HELIX-20K02-M	20	20	45	71	0,2	109	
HELIX-20K02-L	20	20	45	86	0,2	130	
HELIX-20K02-LL	20	20	45	101	0,2	150	

I Z5 HELIX: FRESA H.V. 43°/45° Cuello Rebajado 1°. Chaflán <65HRC CHAFLAN EN ESQUINA / ALTO RENDIMIENTO / MULTIUSOS

- EN** Z5 HELIX: U.H.A. 43-45° | REDUCED NECK 1° | MULTIURPOSE | HIGH PERFORMANCE
FR Z5 HELIX: H.D. 43-45° | DE HAUTE PERFORMANCE
DE Z5 HELIX: U.D. 43-45° | HOCHLEISTUNGSBEARBEITUNG

ES Acero, Acero Inoxidable, Fundición Gris, Cobre, Titanio, Aleaciones Resistentes al Calor y Aceros hasta 65 HRC.

EN Steel, Stainless Steel, Cast Iron, Cooper, Titanium, Heat Resistance Alloys and Hardened Steels up to 65 HRC.

FR Acier, Acier Inoxydable, Fonte Grise, Cuivre, Titane, Alliages de Résistance à la Chaleur et Acier Jusq'ua 65 HRC.

DE Stahl, Rostfreier Stahl, Gubeisen, Kupfer, Titan, Warmfeste Legierungen und Gehärteter Stahl 65 HRC.

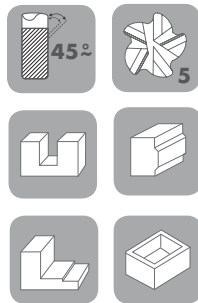

ALTISIN

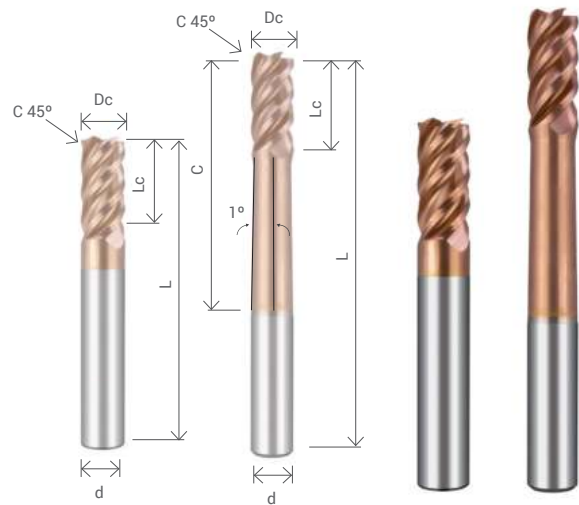

CUELLO REBAJADO A 1°

Ref.	Dimensiones (mm)						Precio €
	Dc	d	Lc	C	C-45°	L	
5 Flutes (Z5)							
S-HELIX-06K01-C	6	6	14	-	0,1	53	
S-HELIX-06K01-M	6	6	14	32	0,1	65	
S-HELIX-06K01-L	6	6	14	42	0,1	75	
S-HELIX-06K01-LL	6	6	14	51	0,1	81	
S-HELIX-08K01-C	8	8	18	-	0,1	60	
S-HELIX-08K01-M	8	8	18	42	0,1	75	
S-HELIX-08K01-L	8	8	18	58	0,1	90	
S-HELIX-08K01-LL	8	8	18	71	0,1	109	
S-HELIX-10K015-C	10	10	22	-	0,15	65	
S-HELIX-10K015-M	10	10	22	51	0,15	81	
S-HELIX-10K015-L	10	10	22	71	0,15	109	
S-HELIX-10K015-LL	10	10	22	82	0,15	109	
S-HELIX-12K02-C	12	12	26	-	0,2	81	
S-HELIX-12K02-M	12	12	26	51	0,2	81	
S-HELIX-12K02-L	12	12	26	71	0,2	109	
S-HELIX-12K02-LL	12	12	26	86	0,2	117	

Z5 HELIX: FRESA H.V. 43°/45° Cuello Rebajado 1°. Chaflán <65HRC CHAFLAN EN ESQUINA / ALTO RENDIMIENTO / MULTIUSOS

EN Z5 HELIX: U.H.A. 43-45° | REDUCED NECK 1° | MULTIURPOSE | HIGH PERFORMANCE

FR Z5 HELIX: H.D. 43-45° | DE HAUTE PERFORMANCE

DE Z5 HELIX: U.D. 43-45° | HOCHLEISTUNGSBEARBEITUNG



Ref.	Dimensiones (mm)						Precio €
5 Flutes (Z5)	Dc	d	Lc	C	C-45°	L	
S-HELIX-16K02-C	16	16	38	-	0,2	81	
S-HELIX-16K02-M	16	16	38	61	0,2	109	
S-HELIX-16K02-L	16	16	38	76	0,2	109	
S-HELIX-16K02-LL	16	16	38	101	0,2	150	
S-HELIX-20K02-C	20	20	45	-	0,2	100	
S-HELIX-20K02-M	20	20	45	71	0,2	109	
S-HELIX-20K02-L	20	20	45	86	0,2	130	
S-HELIX-20K02-LL	20	20	45	101	0,2	150	

Z5 HELIX: FRESA H.V. 43°/45° Chaflán <56HRC. Refrigeración central CHAFLAN EN ESQUINA / CUELLO REBAJADO 1° / ALTO RENDIMIENTO

- EN** Z5 HELIX: UNEQUAL HELIX ANGLES 43-45° | R. NECK 1° | CENTRAL COOLANT | HIGH PERFORMANCE
FR Z5 HELIX: HÉLICE DIFFÉRENTE 43-45°
DE Z5 HELIX: UNGLEICHER DRALLWINKEL 43-45°

ES Acero, Acero Inoxidable, Fundición Gris, Cobre, Titanio, Aleaciones Resistentes al Calor y Aceros hasta 56 HRC.

EN Steel, Stainless Steel, Cast Iron, Cooper, Titanium, Heat Resistance Alloys and Hardened Steels up to 56 HRC.

FR Acier, Acier Inoxydable, Fonte Grise, Cuivre, Titane, Alliages de Résistance à la Chaleur et Acier Jusqu'à 56 HRC.

DE Stahl, Rostfreier Stahl, Gubeisen, Kupfer, Titan, Warmfeste Legierungen und Gehärteter Stahl 56 HRC.



ALTiN TiTAN

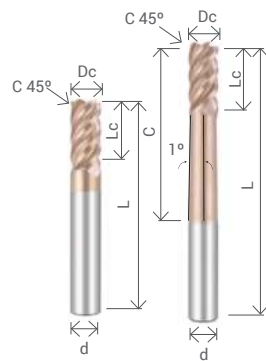

Refrigeración central



CUELLO REBAJADO A 1°

Ref.	Dimensiones (mm)						Precio €
	Dc	d	Lc	C	C-45°	L	
5 Flutes (Z5)							
HELIX-06K01-C-O	6	6	14	-	0,1	53	
HELIX-06K01-M-O	6	6	14	32	0,1	65	
HELIX-06K01-L-O	6	6	14	42	0,1	75	
HELIX-06K01-LL-O	6	6	14	51	0,1	81	
HELIX-08K01-C-O	8	8	18	-	0,1	60	
HELIX-08K01-M-O	8	8	18	42	0,1	75	
HELIX-08K01-L-O	8	8	18	58	0,1	90	
HELIX-08K01-LL-O	8	8	18	71	0,1	109	
HELIX-10K015-C-O	10	10	22	-	0,15	65	
HELIX-10K015-M-O	10	10	22	51	0,15	81	
HELIX-10K015-L-O	10	10	22	71	0,15	109	
HELIX-10K015-LL-O	10	10	22	82	0,15	109	
HELIX-12K02-C-O	12	12	26	-	0,2	81	
HELIX-12K02-M-O	12	12	26	51	0,2	81	
HELIX-12K02-L-O	12	12	26	71	0,2	109	
HELIX-12K02-LL-O	12	12	26	86	0,2	117	

Z5 HELIX: FRESA H.V. 43°/45° Chaflán <56HRC. Refrigeración central CHAFLAN EN ESQUINA / CUELLO REBAJADO 1° / ALTO RENDIMIENTO

EN Z5 HELIX: UNEQUAL HELIX ANGLES 43-45° | R. NECK 1° | CENTRAL COOLANT | HIGH PERFORMANCE

FR Z5 HELIX: HÉLICE DIFFÉRENTE 43-45°

DE Z5 HELIX: UNGLEICHER DRALLWINKEL 43-45°



Ref.	Dimensiones (mm)						Precio €
	Dc	d	Lc	C	C-45°	L	
5 Flutes (Z5)							
HELIX-16K02-C-O	16	16	38	-	0,2	81	
HELIX-16K02-M-O	16	16	38	61	0,2	109	
HELIX-16K02-L-O	16	16	38	76	0,2	109	
HELIX-16K02-LL-O	16	16	38	101	0,2	150	
HELIX-20K02-C-O	20	20	45	-	0,2	100	
HELIX-20K02-M-O	20	20	45	71	0,2	109	
HELIX-20K02-L-O	20	20	45	86	0,2	130	
HELIX-20K02-LL-O	20	20	45	101	0,2	150	

Z5 HELIX: FRESA HELICE VARIABLE 43°/45° Radio <56HRC MULTIUSOS / CUELLO REBAJADO 1°

- EN** Z5 HELIX: U.H.A. 43-45° | R. NECK 1° | HIGH PERFORMANCE | MULTI PURPOSE | CORNER RADIUS
FR Z5 HELIX: H.D. 43-45° | R. NECK 1° | HAUTE PERFORMANCE
DE Z5 HELIX: U. D. 43-45° | R. NECK 1° | HOCHLEISTUNGSBEARBEITUNG

- ES** Acero, Acero Inoxidable, Fundición Gris, Cobre, Titanio, Aleaciones Resistentes al Calor y Aceros hasta 56 HRC.
EN Steel, Stainless Steel, Cast Iron, Cooper, Titanium, Heat Resistance Alloys and Hardened Steels up to 56 HRC.
FR Acier, Acier Inoxydable, Fonte Grise, Cuivre, Titane, Alliages de Résistance à la Chaleur et Acier Jusqu'à 56 HRC.
DE Stahl, Rostfreier Stahl, Gubeisen, Kupfer, Titan, Warmfeste Legierungen und Gehärteter Stahl 56 HRC.

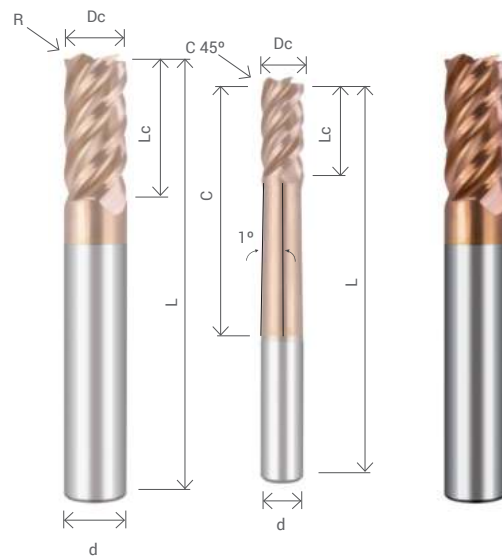
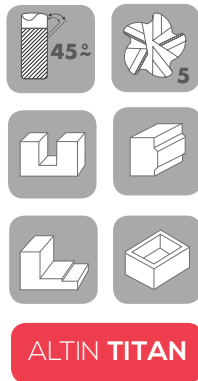

CUELLO REBAJADO A 1°

Ref.	Dimensiones (mm)						Precio €
	Dc	d	Lc	C	R	L	
5 Flutes (Z5)							
HELIX-06R05-C	6	6	14	-	0,5	53	
HELIX-06R05-M	6	6	14	32	0,5	65	
HELIX-06R05-L	6	6	14	42	0,5	75	
HELIX-06R05-LL	6	6	14	51	0,5	81	
HELIX-08R05-C	8	8	18	-	0,5	60	
HELIX-08R05-M	8	8	18	42	0,5	75	
HELIX-08R05-L	8	8	18	58	0,5	90	
HELIX-08R05-LL	8	8	18	71	0,5	109	
HELIX-10R05-C	10	10	22	-	0,5	65	
HELIX-10R05-M	10	10	22	51	0,5	81	
HELIX-10R05-L	10	10	22	71	0,5	109	
HELIX-10R05-LL	10	10	22	82	0,5	109	
HELIX-12R1-C	12	12	26	-	1	81	
HELIX-12R1-M	12	12	26	51	1	81	
HELIX-12R1-L	12	12	26	71	1	109	
HELIX-12R1-LL	12	12	26	86	1	117	

Z5 HELIX: FRESA HELICE VARIABLE 43°/45° Radio <56HRC MULTIUSOS / CUELLO REBAJADO 1°

- EN** Z5 HELIX: U.H.A. 43-45° | R. NECK 1° | HIGH PERFORMANCE | MULTI PURPOSE | CORNER RADIUS
FR Z5 HELIX: H.D. 43-45° | R. NECK 1° | HAUTE PERFORMANCE
DE Z5 HELIX: U. D. 43-45° 1° | R. NECK 1° | HOCHLEISTUNGSBEARBEITUNG



Ref.	Dimensiones (mm)						Precio €
	Dc	d	Lc	C	R	L	
5 Flutes (Z5)							
HELIX-16R2-C	16	16	38	-	2	81	
HELIX-16R2-M	16	16	38	61	2	109	
HELIX-16R2-L	16	16	38	76	2	109	
HELIX-16R2-LL	16	16	38	101	2	150	
HELIX-20R2-C	20	20	45	-	2	100	
HELIX-20R2-M	20	20	45	71	2	109	
HELIX-20R2-L	20	20	45	86	2	130	
HELIX-20R2-LL	20	20	45	101	2	150	

Z5 HELIX: FRESA HELICE VARIABLE 43°/45° Radio <65HRC MULTIUSOS / ALTO RENDIMIENTO / CUELLO REBAJADO 1°

- EN** Z5 HELIX: U.H. A. 43-45° | REDUCED NECK 1° | HIGH PERFORMANCE | MULTI PURPOSE | CORNER RADIUS
FR Z5 HELIX: H.D. 43-45° | DE HAUTE PERFORMANCE
DE Z5 HELIX: U. D. 43-45° | HOCHLEISTUNGSBEARBEITUNG

ES Acero, Acero Inoxidable, Fundición Gris, Cobre, Titanio, Aleaciones Resistentes al Calor y Aceros hasta 65 HRC.

EN Steel, Stainless Steel, Cast Iron, Cooper, Titanium, Heat Resistance Alloys and Hardened Steels up to 65 HRC.

FR Acier, Acier Inoxydable, Fonte Grise, Cuivre, Titane, Alliages de Résistance à la Chaleur et Acier Jusqu'à 65 HRC.

DE Stahl, Rostfreier Stahl, Gubeisen, Kupfer, Titan, Warmfeste Legierungen und Gehärteter Stahl 65 HRC.

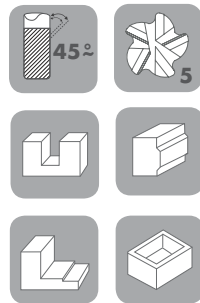

ALTISIN

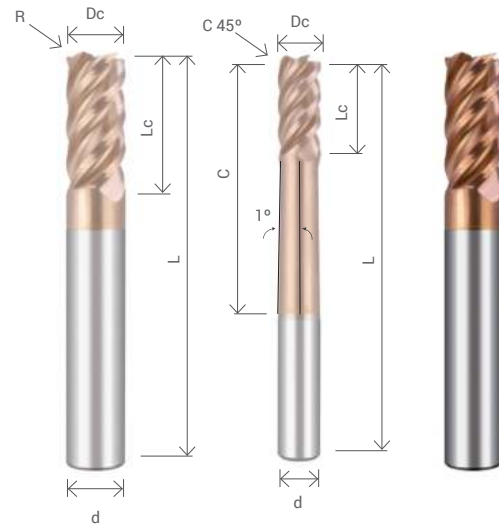

CUELLO REBAJADO A 1°

Ref.	Dimensiones (mm)						Precio €
	Dc	d	Lc	C	R	L	
5 Flutes (Z5)							
S-HELIX-06R05-C	6	6	14	-	0,5	53	
S-HELIX-06R05-M	6	6	14	32	0,5	65	
S-HELIX-06R05-L	6	6	14	42	0,5	75	
S-HELIX-06R05-LL	6	6	14	51	0,5	81	
S-HELIX-08R05-C	8	8	18	-	0,5	60	
S-HELIX-08R05-M	8	8	18	42	0,5	75	
S-HELIX-08R05-L	8	8	18	58	0,5	90	
S-HELIX-08R05-LL	8	8	18	71	0,5	109	
S-HELIX-10R05-C	10	10	22	-	0,5	65	
S-HELIX-10R05-M	10	10	22	51	0,5	81	
S-HELIX-10R05-L	10	10	22	71	0,5	109	
S-HELIX-10R05-LL	10	10	22	82	0,5	109	
S-HELIX-12R1-C	12	12	26	-	1	81	
S-HELIX-12R1-M	12	12	26	51	1	81	
S-HELIX-12R1-L	12	12	26	71	1	109	
S-HELIX-12R1-LL	12	12	26	86	1	117	

Z5 HELIX: FRESA HELICE VARIABLE 43°/45° Radio <65HRC

MULTIUSOS / ALTO RENDIMIENTO / CUELLO REBAJADO 1°

- EN** Z5 HELIX: U.H. A. 43-45° | REDUCED NECK 1° | HIGH PERFORMANCE | MULTI PURPOSE | CORNER RADIUS
FR Z5 HELIX: H.D. 43-45° | DE HAUTE PERFORMANCE
DE Z5 HELIX: U. D. 43-45° | HOCHLEISTUNGSBEARBEITUNG



Ref.	Dimensiones (mm)						Precio €
	Dc	d	Lc	C	R	L	
5 Flutes (Z5)							
S-HELIX-16R2-C	16	16	38	-	2	81	
S-HELIX-16R2-M	16	16	38	61	2	109	
S-HELIX-16R2-L	16	16	38	76	2	109	
S-HELIX-16R2-LL	16	16	38	101	2	150	
S-HELIX-20R2-C	20	20	45	-	2	100	
S-HELIX-20R2-M	20	20	45	71	2	109	
S-HELIX-20R2-L	20	20	45	86	2	130	
S-HELIX-20R2-LL	20	20	45	101	2	150	

Z5 HELIX: FRESA H.V. 43°/45° Radio <55HRC Refrigeración central MULTIUSOS / ALTO RENDIMIENTO / CUELLO REBAJADO 1°

- EN** Z5 HELIX: U.H.A. 43-45° | R. NECK 1° | H. PERFORMANCE | MULTI PURPOSE | CORNER RADIUS | COOLANT
FR Z5 HELIX: H. D. 43-45° | HAUTE PERFORMANCE
DE Z5 HELIX: U.D. 43-45° | HOCHLEISTUNGSBEARBEITUNG

ES Acero, Acero Inoxidable, Fundición Gris, Cobre, Titanio, Aleaciones Resistentes al Calor y Aceros hasta 56 HRC.

EN Steel, Stainless Steel, Cast Iron, Cooper, Titanium, Heat Resistance Alloys and Hardened Steels up to 56 HRC.

FR Acier, Acier Inoxydable, Fonte Grise, Cuivre, Titane, Alliages de Résistance à la Chaleur et Acier Jusqu'à 56 HRC.

DE Stahl, Rostfreier Stahl, Gubeisen, Kupfer, Titan, Warmfeste Legierungen und Gehärteter Stahl 56 HRC.

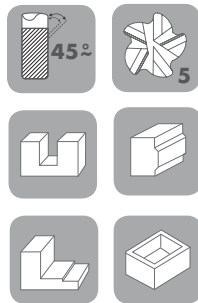

ALTiN TiTAN

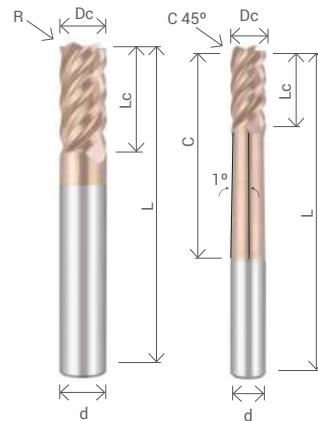

Refrigeración central



CUELLO REBAJADO A 1°

Ref.	Dimensiones (mm)						Precio €
5 Flutes (Z5)	Dc	d	Lc	C	R	L	
HELIX-06R05-C-O	6	6	14	-	0,5	53	
HELIX-06R05-M-O	6	6	14	32	0,5	65	
HELIX-06R05-L-O	6	6	14	42	0,5	75	
HELIX-06R05-LL-O	6	6	14	51	0,5	81	
HELIX-08R05-C-O	8	8	18	-	0,5	60	
HELIX-08R05-M-O	8	8	18	42	0,5	75	
HELIX-08R05-L-O	8	8	18	58	0,5	90	
HELIX-08R05-LL-O	8	8	18	71	0,5	109	
HELIX-10R05-C-O	10	10	22	-	0,5	65	
HELIX-10R05-M-O	10	10	22	51	0,5	81	
HELIX-10R05-L-O	10	10	22	71	0,5	109	
HELIX-10R05-LL-O	10	10	22	82	0,5	109	
HELIX-12R1-C-O	12	12	26	-	1	81	

Z5 HELIX: FRESA H.V. 43°/45° Radio <55HRC Refrigeración central MULTIUSOS / ALTO RENDIMIENTO / CUELLO REBAJADO 1°

- EN** Z5 HELIX: U.H.A. 43-45° | R. NECK 1° | H. PERFORMANCE | MULTI PURPOSE | CORNER RADIUS | COOLANT
FR Z5 HELIX: H. D. 43-45° | HAUTE PERFORMANCE
DE Z5 HELIX: U.D. 43-45° | HOCHLEISTUNGSBEARBEITUNG



Ref.	Dimensiones (mm)						Precio €
	Dc	d	Lc	C	R	L	
5 Flutes (Z5)							
HELIX-12R1-M-O	12	12	26	51	1	81	
HELIX-12R1-L-O	12	12	26	71	1	109	
HELIX-12R1-LL-O	12	12	26	86	1	117	
HELIX-16R2-C-O	16	16	38	-	2	81	
HELIX-16R2-M-O	16	16	38	61	2	109	
HELIX-16R2-L-O	16	16	38	76	2	109	
HELIX-16R2-LL-O	16	16	38	101	2	150	
HELIX-20R2-C-O	20	20	45	-	2	100	
HELIX-20R2-M-O	20	20	45	71	2	109	
HELIX-20R2-L-O	20	20	45	86	2	130	
HELIX-20R2-LL-O	20	20	45	101	2	150	

I Z4 HYPERBALL: FRESA HÉLICE VARIABLE ESFÉRICA

- EN** Z4 HYPERBALL: BALL NOSE END MILL | UNEQUAL HELIX ANGLES
FR Z4 HYPERBALL: FRAISE CYLINDRIQUE HÉMISPHERIQUE | HÉLICE DIFFÉRENTE
DE Z4 HYPERBALL: UNGLEICHER DRALLWINKEL | KUGELFRÄSER

ES Acero, Acero Inoxidable, Fundición Gris, Cobre, Titanio, Aleaciones Resistentes al Calor y Aceros hasta 65 HRC.

EN Steel, Stainless Steel, Cast Iron, Cooper, Titanium, Heat Resistance Alloys and Hardened Steels up to 65 HRC.

FR Acier, Acier Inoxydable, Fonte Grise, Cuivre, Titane, Alliages de Résistance à la Chaleur et Acier Jusqu'à 65 HRC.

DE Stahl, Rostfreier Stahl, Gubeisen, Kupfer, Titan, Warmfeste Legierungen und Gehärteter Stahl 65 HRC.

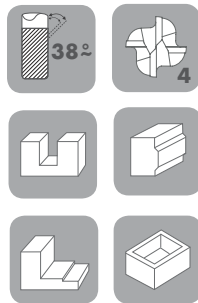

ALTISIN

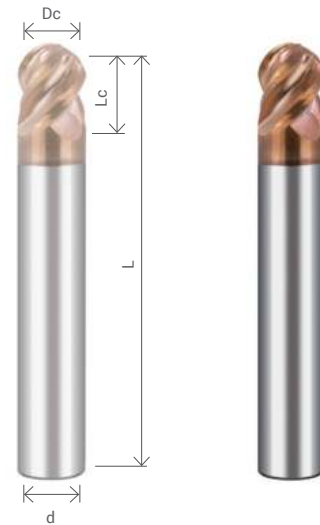

Ref.	Dimensiones (mm)				Precio €
	Dc	d	Lc	L	
4 Flutes (Z4)					
HPB-4060	6	6	8	50	
HPB-4060L	6	6	8	80	
HPB-4060XL	6	6	8	100	
HPB-4060XXL	6	6	8	150	
HPB-4080	8	8	10	60	
HPB-4080L	8	8	10	100	
HPB-4080XL	8	8	10	150	
HPB-4100	10	10	13	72	
HPB-4100L	10	10	13	100	
HPB-4100XL	10	10	13	150	
HPB-4100XXL	10	10	13	200	
HPB-4120	12	12	15	75	
HPB-4120L	12	12	15	100	
HPB-4120XL	12	12	15	150	
HPB-4120XXL	12	12	15	200	

Z4 HYPERBALL: FRESA HÉLICE VARIABLE ESFÉRICA. CÓNICA 1,5°

- EN** Z4 HYPERBALL: BALL NOSE END MILL | UNEQUAL HELIX ANGLES | CONICAL 1,5°
FR Z4 HYPERBALL: FRAISE CYLINDRIQUE HÉMISPHERIQUE | HÉLICE DIFFÉRENTE
DE Z4 HYPERBALL: UNGLEICHER DRALLWINKEL | KUGELFRÄSER

ES Acero, Acero Inoxidable, Fundición Gris, Cobre, Titanio, Aleaciones Resistentes al Calor y Aceros hasta 65 HRC.

EN Steel, Stainless Steel, Cast Iron, Cooper, Titanium, Heat Resistance Alloys and Hardened Steels up to 65 HRC.

FR Acier, Acier Inoxydable, Fonte Grise, Cuivre, Titane, Alliages de Résistance à la Chaleur et Acier Jusq'ua 65 HRC.

DE Stahl, Rostfreier Stahl, Gubeisen, Kupfer, Titan, Warmfeste Legierungen und Gehärteter Stahl 65 HRC.

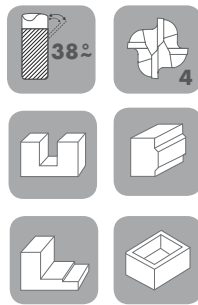

ALTISIN

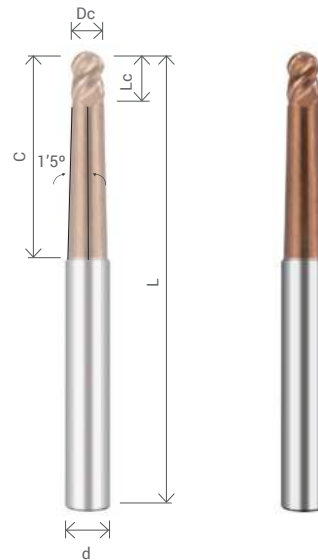

CONICAS CON 1,5°

Ref.	Dimensiones (mm)					Precio €
	Dc	d	Lc	C	L	
HPB-CON4060	6	8	8	32	80	
HPB-CON4060L	6	8	8	45	108	
HPB-CON4080	8	10	10	32	80	
HPB-CON4080L	8	10	10	48	108	

FRESA TURBO ALTO AVANCE Serie Normal

- EN** TURBO HIGH FEED END MILL | Normal series
FR TURBO FRAISE CYLINDRIQUE DE HAUTE AVANCE | Normale
DE TURBO HOCHVORSCHUBFRÄSER | Normale

ES Acero, Acero Inoxidable, Fundición Gris, Cobre, Titanio, Aleaciones Resistentes al Calor y Aceros hasta 65 HRC.

EN Steel, Stainless Steel, Cast Iron, Cooper, Titanium, Heat Resistance Alloys and Hardened Steels up to 65 HRC.

FR Acier, Acier Inoxydable, Fonte Grise, Cuivre, Titane, Alliages de Résistance à la Chaleur et Acier Jusqu'à 65 HRC.

DE Stahl, Rostfreier Stahl, Gubeisen, Kupfer, Titan, Warmfeste Legierungen und Gehärteter Stahl 65 HRC.



ALTISIN



SERIE NORMAL

Ref.	Dimensiones (mm)						Precio €
	Dc	d	R	Lc	U	L	
4 Flutes (Z4)							
T-SEM4030X-R0,5	3	6	0,5	1,5	12	60	
T-SEM4040X-R0,5	4	6	0,5	2	12	60	
T-SEM4060X-R0,5	6	6	0,5	3	14	60	
T-SEM4060X-R1.0	6	6	1	3	14	60	
T-SEM4080X-R1.0	8	8	1	4	18	60	
T-SEM4080X-R2.0	8	8	2	4	18	60	
T-SEM4100X-R1.0	10	10	1	5	20	72	
T-SEM4100X-R2.0	10	10	2	5	20	72	
T-SEM4120X-R2.0	12	12	2	6	22	83	
T-SEM4120X-R3.0	12	12	3	6	22	83	

L1.= Long rebajada del cuello
d.= diametro mango

I FRESA TURBO ALTO AVANCE Serie Larga

- EN** TURBO HIGH FEED END MILL | Long series
FR TURBO FRAISE CYLINDRIQUE DE HAUTE AVANCE | Longue
DE TURBO HOCHVORSCHUBFRÄSER | Lange

ES Acero, Acero Inoxidable, Fundición Gris, Cobre, Titanio, Aleaciones Resistentes al Calor y Aceros hasta 65 HRC.

EN Steel, Stainless Steel, Cast Iron, Cooper, Titanium, Heat Resistance Alloys and Hardened Steels up to 65 HRC.

FR Acier, Acier Inoxydable, Fonte Grise, Cuivre, Titane, Alliages de Résistance à la Chaleur et Acier Jusq'ua 65 HRC.

DE Stahl, Rostfreier Stahl, Gubeisen, Kupfer, Titan, Warmfeste Legierungen und Gehärteter Stahl 65 HRC.

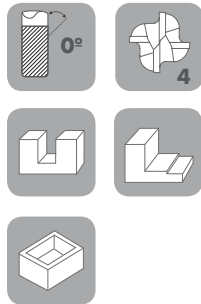

ALTISIN



SERIE LARGA

Ref.	Dimensiones (mm)						Precio €
	Dc	d	R	Lc	U	L	
4 Flutes (Z4)							
T-SEM4030XL-R0,5	3	6	0,5	1,5	20	80	
T-SEM4040XL-R0,5	4	6	0,5	2	20	80	
T-SEM4060XL-R1.0	6	6	1	3	30	80	
T-SEM4080XL-R2.0	8	8	2	4	40	80	
T-SEM4100XL-R2.0	10	10	2	5	50	100	
T-SEM4120XL-R2.0	12	12	2	6	50	110	

L1.= Long rebajada del cuello
d.= diametro mango

I FRESA PARA ACHAFLANAR 60°

- EN** COUNTERSINKER, 60°
FR CHAMFREIN, 60°
DE KEGELSENKER, 60°

ES Acero, Acero Inoxidable, Fundición Gris, Cobre, Titanio, Aleaciones Resistentes al Calor y Aceros hasta 56 HRC.

EN Steel, Stainless Steel, Cast Iron, Cooper, Titanium, Heat Resistance Alloys and Hardened Steels up to 56 HRC.

FR Acier, Acier Inoxydable, Fonte Grise, Cuivre, Titane, Alliages de Résistance à la Chaleur et Acier Jusqu'à 56 HRC.

DE Stahl, Rostfreier Stahl, Gubeisen, Kupfer, Titan, Warmfeste Legierungen und Gehärteter Stahl 56 HRC.



ALTiN



Ref.	Dimensiones (mm)				Precio €
	Dc	d	Z	L	
ACH60-SEM4040	4	4	4	50	
ACH60-SEM4060	6	6	4	50	
ACH60-SEM4080	8	8	4	60	
ACH60-SEM4100	10	10	4	72	
ACH60-SEM6100	10	10	6	72	
ACH60-SEM4120	12	12	4	75	
ACH60-SEM6120	12	12	6	75	

FRESA PARA ACHAFLANAR 90°

- EN COUNTERSINKER, 90°
FR CHAMFREIN, 90°
DE KEGELSENKER, 90°

ES Acero, Acero Inoxidable, Fundición Gris, Cobre, Titanio, Aleaciones Resistentes al Calor y Aceros hasta 56 HRC.

EN Steel, Stainless Steel, Cast Iron, Cooper, Titanium, Heat Resistance Alloys and Hardened Steels up to 56 HRC.

FR Acier, Acier Inoxydable, Fonte Grise, Cuivre, Titane, Alliages de Résistance à la Chaleur et Acier Jusqu'à 56 HRC.

DE Stahl, Rostfreier Stahl, Gubeisen, Kupfer, Titan, Warmfeste Legierungen und Gehärteter Stahl 56 HRC.



ALTIN



Ref.	Dimensiones (mm)				Precio €
REF.	Dc	d	Z	L	
ACH90-SEM4040	4	4	4	50	
ACH90-SEM4060	6	6	4	50	
ACH90-SEM4080	8	8	4	60	
ACH90-SEM6080	8	8	6	60	
ACH90-SEM4100	10	10	4	72	
ACH90-SEM6100	10	10	6	72	
ACH90-SEM4120	12	12	4	75	
ACH90-SEM6120	12	12	6	75	
ACH90-SEM4160	16	16	4	92	
ACH90-SEM6160	16	16	6	92	

I Z5 TROCOIDAL: FRESA DE ALTO RENDIMIENTO CUELLO REBAJADO

EN Z5 TROCHOIDAL. HIGH PERFORMANCE END MILL | REDUCED NECK

FR Z5 TROCOIDALE. FRAISE DE HAUTE PERFORMANCE

DE Z5 TROCHOIDALFRÄSER. UNGLEICHER DRALLWINKEL HOCHLEISTUNGSBEARBEITUNG

ES Acero, Acero Inoxidable, Fundición Gris, Cobre, Titanio, Aleaciones Resistentes al Calor y Aceros hasta 56 HRC.

EN Steel, Stainless Steel, Cast Iron, Cooper, Titanium, Heat Resistance Alloys and Hardened Steels up to 56 HRC.

FR Acier, Acier Inoxydable, Fonte Grise, Cuivre, Titane, Alliages de Résistance à la Chaleur et Acier Jusq'ua 56 HRC.

DE Stahl, Rostfreier Stahl, Gubeisen, Kupfer, Titan, Warmfeste Legierungen und Gehärteter Stahl 56 HRC.

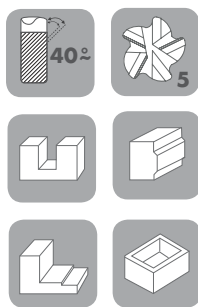

ALTIN NANO



ALTO RENDIMIENTO

Ref.	Dimensiones (mm)						Precio €
	Dc	d	Lc	U	C-45°	L	
5 Flutes (Z5)							
TR-5060U25H	6	6	18	25	0,1	62	
TR-5080U30H	8	8	24	30	0,15	70	
TR-5100U35H	10	10	30	35	0,2	80	
TR-5120U45H	12	12	36	45	0,2	94	
TR-5160U55H	16	16	48	55	0,4	110	
TR-5200U70H	20	20	60	70	0,4	126	

06

BROCAS de metal duro

SOLID CARBIDE DRILL
FORET EN CARBURE MONOBLOC
VOLLHARTMETALLBOHRER

3XD BROCA DE METAL DURO

DIN6537K

- EN** 3xD SOLID CARBIDE DRILL | DIN6537K
FR 3xD FORET EN CARBURE MONOBLOC | DIN6537K
DE 3xD VOLLHARTMETALLBOHRER | DIN6537K

ES Acero, Acero Inoxidable, Fundición Gris, Cobre, Titanio, Aleaciones Resistentes al Calor y Aceros hasta 56 HRC.

EN Steel, Stainless Steel, Cast Iron, Cooper, Titanium, Heat Resistance Alloys and Hardened Steels up to 56 HRC.

FR Acier, Acier Inoxydable, Fonte Grise, Cuivre, Titane, Alliages de Résistance à la Chaleur et Acier Jusqu'à 56 HRC.

DE Stahl, Rostfreier Stahl, Gubeisen, Kupfer, Titan, Warmfeste Legierungen und Gehärteter Stahl 56 HRC.

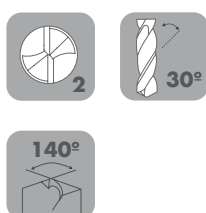

ALTIN



Dc = tolerancia h8
d = tolerancia h6

DIN6537K

Ref.	Dimensiones (mm)					Precio €
	Dc	d	U	Lc	L	
DR0300D3	3	6	20	14	62	
DR0310D3	3,1	6	20	14	62	
DR0320D3	3,2	6	20	14	62	
DR0330D3	3,3	6	20	14	62	
DR0340D3	3,4	6	20	14	62	
DR0350D3	3,5	6	20	14	62	
DR0360D3	3,6	6	20	14	62	
DR0370D3	3,7	6	20	14	62	
DR0380D3	3,8	6	24	17	66	
DR0390D3	3,9	6	24	17	66	
DR0400D3	4	6	24	17	66	
DR0410D3	4,1	6	24	17	66	
DR0420D3	4,2	6	24	17	66	
DR0430D3	4,3	6	24	17	66	
DR0440D3	4,4	6	24	17	66	
DR0450D3	4,5	6	24	17	66	

3XD BROCA DE METAL DURO

DIN6537K



Ref.	Dimensiones (mm)					Precio €
	5 Flutes (Z5)	Dc	d	U	Lc	
DR0460D3		4,6	6	24	17	66
DR0470D3		4,7	6	24	17	66
DR0480D3		4,8	6	28	20	66
DR0490D3		4,9	6	28	20	66
DR0500D3		5	6	28	20	66
DR0510D3		5,1	6	28	20	66
DR0520D3		5,2	6	28	20	66
DR0530D3		5,3	6	28	20	66
DR0540D3		5,4	6	28	20	66
DR0550D3		5,5	6	28	20	66
DR0560D3		5,6	6	28	20	66
DR0570D3		5,7	6	28	20	66
DR0580D3		5,8	6	28	20	66
DR0590D3		5,9	6	28	20	66
DR0600D3		6	6	28	20	66
DR0610D3		6,1	8	34	24	79
DR0620D3		6,2	8	34	24	79
DR0630D3		6,3	8	34	24	79
DR0640D3		6,4	8	34	24	79
DR0650D3		6,5	8	34	24	79
DR0660D3		6,6	8	34	24	79
DR0670D3		6,7	8	34	24	79
DR0680D3		6,8	8	34	24	79
DR0690D3		6,9	8	34	24	79
DR0700D3		7	8	34	24	79
DR0710D3		7,1	8	41	29	79
DR0720D3		7,2	8	41	29	79
DR0730D3		7,3	8	41	29	79
DR0740D3		7,4	8	41	29	79
DR0750D3		7,5	8	41	29	79
DR0760D3		7,6	8	41	29	79

3XD BROCA DE METAL DURO

DIN6537K

Ref.	Dimensiones (mm)					Precio €
	Dc	d	U	Lc	L	
DR0770D3	7,7	8	41	29	79	
DR0780D3	7,8	8	41	29	79	
DR0790D3	7,9	8	41	29	79	
DR0800D3	8	8	41	29	79	
DR0810D3	8,1	10	47	35	89	
DR0820D3	8,2	10	47	35	89	
DR0830D3	8,3	10	47	35	89	
DR0840D3	8,4	10	47	35	89	
DR0850D3	8,5	10	47	35	89	
DR0860D3	8,6	10	47	35	89	
DR0870D3	8,7	10	47	35	89	
DR0880D3	8,8	10	47	35	89	
DR0890D3	8,9	10	47	35	89	
DR0900D3	9	10	47	35	89	
DR0910D3	9,1	10	47	35	89	
DR0920D3	9,2	10	47	35	89	
DR0930D3	9,3	10	47	35	89	
DR0940D3	9,4	10	47	35	89	
DR0950D3	9,5	10	47	35	89	
DR0960D3	9,6	10	47	35	89	
DR0970D3	9,7	10	47	35	89	
DR0980D3	9,8	10	47	35	89	
DR0990D3	9,9	10	47	35	89	
DR1000D3	10	10	47	35	89	
DR1010D3	10,1	12	55	40	102	
DR1020D3	10,2	12	55	40	102	
DR1030D3	10,3	12	55	40	102	
DR1040D3	10,4	12	55	40	102	
DR1050D3	10,5	12	55	40	102	
DR1060D3	10,6	12	55	40	102	
DR1070D3	10,7	12	55	40	102	
DR1080D3	10,8	12	55	40	102	
DR1090D3	10,9	12	55	40	102	

3XD BROCA DE METAL DURO

DIN6537K

Ref.	Dimensiones (mm)					Precio €
	Dc	d	U	Lc	L	
DR1100D3	11	12	55	40	102	
DR1110D3	11,1	12	55	40	102	
DR1120D3	11,2	12	55	40	102	
DR1130D3	11,3	12	55	40	102	
DR1140D3	11,4	12	55	40	102	
DR1150D3	11,5	12	55	40	102	
DR1160D3	11,6	12	55	40	102	
DR1170D3	11,7	12	55	40	102	
DR1180D3	11,8	12	55	40	102	
DR1190D3	11,9	12	55	40	102	
DR1200D3	12	12	55	40	102	
DR1220D3	12,2	14	60	43	107	
DR1250D3	12,5	14	60	43	107	
DR1270D3	12,7	14	60	43	107	
DR1280D3	12,8	14	60	43	107	
DR1300D3	13	14	60	43	107	
DR1310D3	13,1	14	60	43	107	
DR1350D3	13,5	14	60	43	107	
DR1380D3	13,8	14	60	43	107	
DR1400D3	14	14	60	43	107	
DR1450D3	14,5	16	65	45	115	
DR1480D3	14,8	16	65	45	115	
DR1500D3	15	16	65	45	115	
DR1550D3	15,5	16	65	45	115	
DR1600D3	16	16	65	45	115	
DR1650D3	16,5	18	73	51	123	
DR1700D3	17	18	73	51	123	
DR1750D3	17,5	18	73	51	123	
DR1800D3	18	18	73	51	123	
DR1850D3	18,5	20	79	55	131	
DR1900D3	19	20	79	55	131	
DR1950D3	19,5	20	79	55	131	
DR2000D3	20	20	79	55	131	

5XD BROCA PARA METAL DURO Con refrigeración DIN6537L

EN 5xD SOLID CARBIDE DRILL | DIN6537L | INTERNAL COOLANT

FR 5xD FORET EN CARBURE MONOBLOC | DIN6537L | AVEC TROUS DE LUBRIFICATION

DE 5xD VOLLHARTMETALLBOHRER | DIN6537L | INTEME KÜHLUNG

ES Acero, Acero Inoxidable, Fundición Gris, Cobre, Titanio, Aleaciones Resistentes al Calor y Aceros hasta 56 HRC.

EN Steel, Stainless Steel, Cast Iron, Cooper, Titanium, Heat Resistance Alloys and Hardened Steels up to 56 HRC.

FR Acier, Acier Inoxydable, Fonte Grise, Cuivre, Titane, Alliages de Résistance à la Chaleur et Acier Jusq'ua 56 HRC.

DE Stahl, Rostfreier Stahl, Gubeisen, Kupfer, Titan, Warmfeste Legierungen und Gehärteter Stahl 56 HRC.

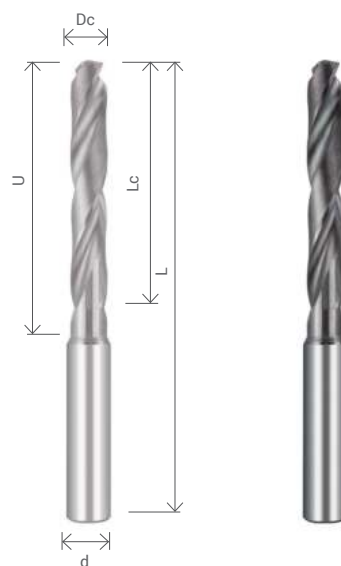
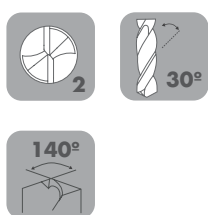

Dc = tolerancia h8
d = tolerancia h6

DIN6537L

Ref.	Dimensiones (mm)					Precio €
	Dc	d	U	Lc	L	
DR0300D5CH	3	6	28	23	66	
DR0310D5CH	3,1	6	28	23	66	
DR0320D5CH	3,2	6	28	23	66	
DR0330D5CH	3,3	6	28	23	66	
DR0340D5CH	3,4	6	28	23	66	
DR0350D5CH	3,5	6	28	23	66	
DR0360D5CH	3,6	6	28	23	66	
DR0370D5CH	3,7	6	28	23	66	
DR0380D5CH	3,8	6	36	29	74	
DR0390D5CH	3,9	6	36	29	74	
DR0400D5CH	4	6	36	29	74	
DR0410D5CH	4,1	6	36	29	74	
DR0420D5CH	4,2	6	36	29	74	
DR0430D5CH	4,3	6	36	29	74	
DR0440D5CH	4,4	6	36	29	74	
DR0450D5CH	4,5	6	36	29	74	

I 5XD BROCA PARA METAL DURO Con refrigeración

DIN6537L



Ref.	Dimensiones (mm)					Precio €
	Dc	d	U	Lc	L	
DR0460D5CH	4,6	6	36	29	74	
DR0470D5CH	4,7	6	36	29	74	
DR0480D5CH	4,8	6	44	35	82	
DR0490D5CH	4,9	6	44	35	82	
DR0500D5CH	5	6	44	35	82	
DR0510D5CH	5,1	6	44	35	82	
DR0520D5CH	5,2	6	44	35	82	
DR0530D5CH	5,3	6	44	35	82	
DR0540D5CH	5,4	6	44	35	82	
DR0550D5CH	5,5	6	44	35	82	
DR0560D5CH	5,6	6	44	35	82	
DR0570D5CH	5,7	6	44	35	82	
DR0580D5CH	5,8	6	44	35	82	
DR0590D5CH	5,9	6	44	35	82	
DR0600D5CH	6	6	44	35	82	
DR0610D5CH	6,1	8	53	43	91	
DR0620D5CH	6,2	8	53	43	91	
DR0630D5CH	6,3	8	53	43	91	
DR0640D5CH	6,4	8	53	43	91	
DR0650D5CH	6,5	8	53	43	91	
DR0660D5CH	6,6	8	53	43	91	
DR0670D5CH	6,7	8	53	43	91	
DR0680D5CH	6,8	8	53	43	91	
DR0690D5CH	6,9	8	53	43	91	
DR0700D5CH	7	8	53	43	91	
DR0710D5CH	7,1	8	53	43	91	
DR0720D5CH	7,2	8	53	43	91	
DR0730D5CH	7,3	8	53	43	91	
DR0740D5CH	7,4	8	53	43	91	
DR0750D5CH	7,5	8	53	43	91	
DR0760D5CH	7,6	8	53	43	91	

I 5XD BROCA PARA METAL DURO Con refrigeración

DIN6537L

Ref.	Dimensiones (mm)					Precio €
	Dc	d	U	Lc	L	
DR0770D5CH	7,7	8	53	43	91	
DR0780D5CH	7,8	8	53	43	91	
DR0790D5CH	7,9	8	53	43	91	
DR0800D5CH	8	8	53	43	91	
DR0810D5CH	8,1	10	61	49	103	
DR0820D5CH	8,2	10	61	49	103	
DR0830D5CH	8,3	10	61	49	103	
DR0840D5CH	8,4	10	61	49	103	
DR0850D5CH	8,5	10	61	49	103	
DR0860D5CH	8,6	10	61	49	103	
DR0870D5CH	8,7	10	61	49	103	
DR0880D5CH	8,8	10	61	49	103	
DR0890D5CH	8,9	10	61	49	103	
DR0900D5CH	9	10	61	49	103	
DR0910D5CH	9,1	10	61	49	103	
DR0920D5CH	9,2	10	61	49	103	
DR0930D5CH	9,3	10	61	49	103	
DR0940D5CH	9,4	10	61	49	103	
DR0950D5CH	9,5	10	61	49	103	
DR0960D5CH	9,6	10	61	49	103	
DR0970D5CH	9,7	10	61	49	103	
DR0980D5CH	9,8	10	61	49	103	
DR0990D5CH	9,9	10	61	49	103	
DR1000D5CH	10	10	61	49	103	
DR1010D5CH	10,1	12	71	56	118	
DR1020D5CH	10,2	12	71	56	118	
DR1030D5CH	10,3	12	71	56	118	
DR1040D5CH	10,4	12	71	56	118	
DR1050D5CH	10,5	12	71	56	118	
DR1060D5CH	10,6	12	71	56	118	
DR1070D5CH	10,7	12	71	56	118	
DR1080D5CH	10,8	12	71	56	118	
DR1090D5CH	10,9	12	71	56	118	

5XD BROCA PARA METAL DURO Con refrigeración

DIN6537L

Ref.	Dimensiones (mm)					Precio €
	Dc	d	U	Lc	L	
DR1100D5CH	11	12	71	56	118	
DR1110D5CH	11,1	12	71	56	118	
DR1120D5CH	11,2	12	71	56	118	
DR1130D5CH	11,3	12	71	56	118	
DR1140D5CH	11,4	12	71	56	118	
DR1150D5CH	11,5	12	71	56	118	
DR1160D5CH	11,6	12	71	56	118	
DR1170D5CH	11,7	12	71	56	118	
DR1180D5CH	11,8	12	71	56	118	
DR1190D5CH	11,9	12	71	56	118	
DR1200D5CH	12	12	71	56	118	
DR1220D5CH	12,2	14	77	60	124	
DR1250D5CH	12,5	14	77	60	124	
DR1270D5CH	12,7	14	77	60	124	
DR1280D5CH	12,8	14	77	60	124	
DR1300D5CH	13	14	77	60	124	
DR1310D5CH	13,1	14	77	60	124	
DR1350D5CH	13,5	14	77	60	124	
DR1380D5CH	13,8	14	77	60	124	
DR1400D5CH	14	14	77	60	124	
DR1450D5CH	14,5	16	83	63	133	
DR1480D5CH	14,8	16	83	63	133	
DR1500D5CH	15	16	83	63	133	
DR1550D5CH	15,5	16	83	63	133	
DR1600D5CH	16	16	83	63	133	
DR1650D5CH	16,5	18	93	71	143	
DR1700D5CH	17	18	93	71	143	
DR1750D5CH	17,5	18	93	71	143	
DR1800D5CH	18	18	93	71	143	
DR1850D5CH	18,5	20	101	77	153	
DR1900D5CH	19	20	101	77	153	
DR1950D5CH	19,5	20	101	77	153	
DR2000D5CH	20	20	101	77	153	

5XD BROCA DE METAL DURO

DIN6537L

- EN** 5xD SOLID CARBIDE DRILL | DIN6537L
FR 5xD FORET EN CARBURE MONOBLOC | DIN6537L
DE 5xD VOLLHARTMETALLBOHRER | DIN6537L

ES Acero, Acero Inoxidable, Fundición Gris, Cobre, Titanio, Aleaciones Resistentes al Calor y Aceros hasta 56 HRC.

EN Steel, Stainless Steel, Cast Iron, Cooper, Titanium, Heat Resistance Alloys and Hardened Steels up to 56 HRC.

FR Acier, Acier Inoxydable, Fonte Grise, Cuivre, Titane, Alliages de Résistance à la Chaleur et Acier Jusqu'à 56 HRC.

DE Stahl, Rostfreier Stahl, Gubeisen, Kupfer, Titan, Warmfeste Legierungen und Gehärteter Stahl 56 HRC.

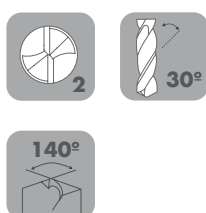

ALTIN



Dc = tolerancia h8
d = tolerancia h6

DIN6537L

Ref.	Dimensiones (mm)					Precio €
	Dc	d	U	Lc	L	
DR0300D5	3	6	28	23	66	
DR0310D5	3,1	6	28	23	66	
DR0320D5	3,2	6	28	23	66	
DR0330D5	3,3	6	28	23	66	
DR0340D5	3,4	6	28	23	66	
DR0350D5	3,5	6	28	23	66	
DR0360D5	3,6	6	28	23	66	
DR0370D5	3,7	6	28	23	66	
DR0380D5	3,8	6	36	29	74	
DR0390D5	3,9	6	36	29	74	
DR0400D5	4	6	36	29	74	
DR0410D5	4,1	6	36	29	74	
DR0420D5	4,2	6	36	29	74	
DR0430D5	4,3	6	36	29	74	
DR0440D5	4,4	6	36	29	74	
DR0450D5	4,5	6	36	29	74	

I 5XD BROCA DE METAL DURO

DIN6537L



Ref.	Dimensiones (mm)					Precio €
	Dc	d	U	Lc	L	
DR0460D5	4,6	6	36	29	74	
DR0470D5	4,7	6	36	29	74	
DR0480D5	4,8	6	44	35	82	
DR0490D5	4,9	6	44	35	82	
DR0500D5	5	6	44	35	82	
DR0510D5	5,1	6	44	35	82	
DR0520D5	5,2	6	44	35	82	
DR0530D5	5,3	6	44	35	82	
DR0540D5	5,4	6	44	35	82	
DR0550D5	5,5	6	44	35	82	
DR0560D5	5,6	6	44	35	82	
DR0570D5	5,7	6	44	35	82	
DR0580D5	5,8	6	44	35	82	
DR0590D5	5,9	6	44	35	82	
DR0600D5	6	6	44	35	82	
DR0610D5	6,1	8	53	43	91	
DR0620D5	6,2	8	53	43	91	
DR0630D5	6,3	8	53	43	91	
DR0640D5	6,4	8	53	43	91	
DR0650D5	6,5	8	53	43	91	
DR0660D5	6,6	8	53	43	91	
DR0670D5	6,7	8	53	43	91	
DR0680D5	6,8	8	53	43	91	
DR0690D5	6,9	8	53	43	91	
DR0700D5	7	8	53	43	91	
DR0710D5	7,1	8	53	43	91	
DR0720D5	7,2	8	53	43	91	
DR0730D5	7,3	8	53	43	91	
DR0740D5	7,4	8	53	43	91	
DR0750D5	7,5	8	53	43	91	
DR0760D5	7,6	8	53	43	91	

I 5XD BROCA DE METAL DURO

DIN6537L

Ref.	Dimensiones (mm)					Precio €
	Dc	d	U	Lc	L	
DR0770D5	7,7	8	53	43	91	
DR0780D5	7,8	8	53	43	91	
DR0790D5	7,9	8	53	43	91	
DR0800D5	8	8	53	43	91	
DR0810D5	8,1	10	61	49	103	
DR0820D5	8,2	10	61	49	103	
DR0830D5	8,3	10	61	49	103	
DR0840D5	8,4	10	61	49	103	
DR0850D5	8,5	10	61	49	103	
DR0860D5	8,6	10	61	49	103	
DR0870D5	8,7	10	61	49	103	
DR0880D5	8,8	10	61	49	103	
DR0890D5	8,9	10	61	49	103	
DR0900D5	9	10	61	49	103	
DR0910D5	9,1	10	61	49	103	
DR0920D5	9,2	10	61	49	103	
DR0930D5	9,3	10	61	49	103	
DR0940D5	9,4	10	61	49	103	
DR0950D5	9,5	10	61	49	103	
DR0960D5	9,6	10	61	49	103	
DR0970D5	9,7	10	61	49	103	
DR0980D5	9,8	10	61	49	103	
DR0990D5	9,9	10	61	49	103	
DR1000D5	10	10	61	49	103	
DR1010D5	10,1	12	71	56	118	
DR1020D5	10,2	12	71	56	118	
DR1030D5	10,3	12	71	56	118	
DR1040D5	10,4	12	71	56	118	
DR1050D5	10,5	12	71	56	118	
DR1060D5	10,6	12	71	56	118	
DR1070D5	10,7	12	71	56	118	
DR1080D5	10,8	12	71	56	118	
DR1090D5	10,9	12	71	56	118	

I 5XD BROCA DE METAL DURO

DIN6537L

Ref.	Dimensiones (mm)					Precio €
	Dc	d	U	Lc	L	
DR1100D5	11	12	71	56	118	
DR1110D5	11,1	12	71	56	118	
DR1120D5	11,2	12	71	56	118	
DR1130D5	11,3	12	71	56	118	
DR1140D5	11,4	12	71	56	118	
DR1150D5	11,5	12	71	56	118	
DR1160D5	11,6	12	71	56	118	
DR1170D5	11,7	12	71	56	118	
DR1180D5	11,8	12	71	56	118	
DR1190D5	11,9	12	71	56	118	
DR1200D5	12	12	71	56	118	
DR1220D5	12,2	14	77	60	124	
DR1250D5	12,5	14	77	60	124	
DR1270D5	12,7	14	77	60	124	
DR1280D5	12,8	14	77	60	124	
DR1300D5	13	14	77	60	124	
DR1310D5	13,1	14	77	60	124	
DR1350D5	13,5	14	77	60	124	
DR1380D5	13,8	14	77	60	124	
DR1400D5	14	14	77	60	124	
DR1450D5	14,5	16	83	63	133	
DR1480D5	14,8	16	83	63	133	
DR1500D5	15	16	83	63	133	
DR1550D5	15,5	16	83	63	133	
DR1600D5	16	16	83	63	133	
DR1650D5	16,5	18	93	71	143	
DR1700D5	17	18	93	71	143	
DR1750D5	17,5	18	93	71	143	
DR1800D5	18	18	93	71	143	
DR1850D5	18,5	20	101	77	153	
DR1900D5	19	20	101	77	153	
DR1950D5	19,5	20	101	77	153	
DR2000D5	20	20	101	77	153	

8XD BROCA DE METAL DURO Con refrigeración

DIN6537L

EN 8xD SOLID CARBIDE DRILL | DIN6537L | INTERNAL COOLANT

FR 8xD FORET EN CARBURE MONOBLOC | DIN6537L | AVEC TROUS DE LUBRIFICATION

DE 8xD VOLLHARTMETALLBOHRER | DIN6537L | INTEME KÜHLUNG

ES Acero, Acero Inoxidable, Fundición Gris, Cobre, Titanio, Aleaciones Resistentes al Calor y Aceros hasta 56 HRC.

EN Steel, Stainless Steel, Cast Iron, Cooper, Titanium, Heat Resistance Alloys and Hardened Steels up to 56 HRC.

FR Acier, Acier Inoxydable, Fonte Grise, Cuivre, Titane, Alliages de Résistance à la Chaleur et Acier Jusq'ua 56 HRC.

DE Stahl, Rostfreier Stahl, Gubeisen, Kupfer, Titan, Warmfeste Legierungen und Gehärteter Stahl 56 HRC.

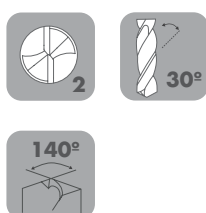

ALTiN

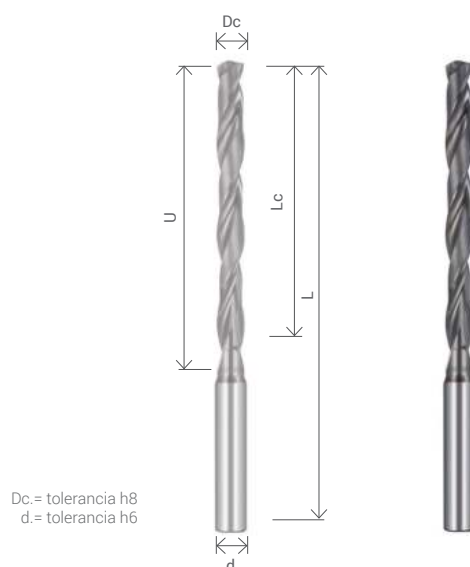

Dc = tolerancia h8
d = tolerancia h6

DIN6537L

Ref.	Dimensiones (mm)					Precio €
	Dc	d	U	Lc	L	
DR0300D8CH	Ø3	6	34	29	72	
DR0310D8CH	Ø3,1	6	34	29	72	
DR0320D8CH	Ø3,2	6	34	29	72	
DR0330D8CH	Ø3,3	6	34	29	72	
DR0340D8CH	Ø3,4	6	34	29	72	
DR0350D8CH	Ø3,5	6	34	29	72	
DR0360D8CH	Ø3,6	6	34	29	72	
DR0370D8CH	Ø3,7	6	34	29	72	
DR0380D8CH	Ø3,8	6	43	36	81	
DR0390D8CH	Ø3,9	6	43	36	81	
DR0400D8CH	Ø4	6	43	36	81	
DR0410D8CH	Ø4,1	6	43	36	81	
DR0420D8CH	Ø4,2	6	43	36	81	
DR0430D8CH	Ø4,3	6	43	36	81	
DR0440D8CH	Ø4,4	6	43	36	81	
DR0450D8CH	Ø4,5	6	43	36	81	

8XD BROCA DE METAL DURO Con refrigeración

DIN6537L



Ref.	Dimensiones (mm)					Precio €
	Dc	d	U	Lc	L	
DR0460D8CH	Ø4,6	6	43	36	81	
DR0470D8CH	Ø4,7	6	43	36	81	
DR0480D8CH	Ø4,8	6	57	48	95	
DR0490D8CH	Ø4,9	6	57	48	95	
DR0500D8CH	Ø5	6	57	48	95	
DR0510D8CH	Ø5,1	6	57	48	95	
DR0520D8CH	Ø5,2	6	57	48	95	
DR0530D8CH	Ø5,3	6	57	48	95	
DR0540D8CH	Ø5,4	6	57	48	95	
DR0550D8CH	Ø5,5	6	57	48	95	
DR0560D8CH	Ø5,6	6	57	48	95	
DR0570D8CH	Ø5,7	6	57	48	95	
DR0580D8CH	Ø5,8	6	57	48	95	
DR0590D8CH	Ø5,9	6	57	48	95	
DR0600D8CH	Ø6	6	57	48	95	
DR0610D8CH	Ø6,1	8	76	66	114	
DR0620D8CH	Ø6,2	8	76	66	114	
DR0630D8CH	Ø6,3	8	76	66	114	
DR0640D8CH	Ø6,4	8	76	66	114	
DR0650D8CH	Ø6,5	8	76	66	114	
DR0660D8CH	Ø6,6	8	76	66	114	
DR0670D8CH	Ø6,7	8	76	66	114	
DR0680D8CH	Ø6,8	8	76	66	114	
DR0690D8CH	Ø6,9	8	76	66	114	
DR0700D8CH	Ø7	8	76	66	114	
DR0710D8CH	Ø7,1	8	76	66	114	
DR0720D8CH	Ø7,2	8	76	66	114	
DR0730D8CH	Ø7,3	8	76	66	114	
DR0740D8CH	Ø7,4	8	76	66	114	
DR0750D8CH	Ø7,5	8	76	66	114	
DR0760D8CH	Ø7,6	8	76	66	114	

I 8XD BROCA DE METAL DURO Con refrigeración

DIN6537L



Ref.	Dimensiones (mm)					Precio €
	Dc	d	U	Lc	L	
DR0770D8CH	Ø7,7	8	76	66	114	
DR0780D8CH	Ø7,8	8	76	66	114	
DR0790D8CH	Ø7,9	8	76	66	114	
DR0800D8CH	Ø8	8	76	66	114	
DR0810D8CH	Ø8,1	10	95	83	142	
DR0820D8CH	Ø8,2	10	95	83	142	
DR0830D8CH	Ø8,3	10	95	83	142	
DR0840D8CH	Ø8,4	10	95	83	142	
DR0850D8CH	Ø8,5	10	95	83	142	
DR0860D8CH	Ø8,6	10	95	83	142	
DR0870D8CH	Ø8,7	10	95	83	142	
DR0880D8CH	Ø8,8	10	95	83	142	
DR0890D8CH	Ø8,9	10	95	83	142	
DR0900D8CH	Ø9	10	95	83	142	
DR0910D8CH	Ø9,1	10	95	83	142	
DR0920D8CH	Ø9,2	10	95	83	142	
DR0930D8CH	Ø9,3	10	95	83	142	
DR0940D8CH	Ø9,4	10	95	83	142	
DR0950D8CH	Ø9,5	10	95	83	142	
DR0960D8CH	Ø9,6	10	95	83	142	
DR0970D8CH	Ø9,7	10	95	83	142	
DR0980D8CH	Ø9,8	10	95	83	142	
DR0990D8CH	Ø9,9	10	95	83	142	
DR1000D8CH	Ø10	10	95	83	142	
DR1020D8CH	Ø10,2	12	114	99	162	
DR1040D8CH	Ø10,4	12	114	99	162	
DR1050D8CH	Ø10,5	12	114	99	162	
DR1080D8CH	Ø10,8	12	114	99	162	
DR1100D8CH	Ø11	12	114	99	162	
DR1150D8CH	Ø11,5	12	114	99	162	
DR1180D8CH	Ø11,8	12	114	99	162	

8XD BROCA DE METAL DURO Con refrigeración

DIN6537L



Ref.	Dimensiones (mm)					Precio €
	Dc	d	U	Lc	L	
DR1200D8CH	Ø12	12	114	99	162	
DR1250D8CH	Ø12,5	14	133	116	178	
DR1300D8CH	Ø13	14	133	116	178	
DR1350D8CH	Ø13,5	14	133	116	178	
DR1380D8CH	Ø13,8	14	133	116	178	
DR1400D8CH	Ø14	14	133	116	178	
DR1450D8CH	Ø14,5	16	152	132	203	
DR1500D8CH	Ø15	16	152	132	203	
DR1550D8CH	Ø15,5	16	152	132	203	
DR1600D8CH	Ø16	16	152	132	203	
DR1650D8CH	Ø16,5	18	171	149	222	
DR1700D8CH	Ø17	18	171	149	222	
DR1750D8CH	Ø17,5	18	171	149	222	
DR1800D8CH	Ø18	18	171	149	222	
DR1850D8CH	Ø18,5	20	190	170	243	
DR1900D8CH	Ø19	20	190	170	243	
DR1950D8CH	Ø19,5	20	190	170	243	
DR2000D8CH	Ø20	20	190	170	243	



07

ESCARIADORES

REAMERS
ALÉSOIRS
REIBAHLEN

ESCARIADOR DE METAL DURO Sin recubrimiento

H7

- EN REAMERS | H7
- FR ALÉSOIRS | H7
- DE REIBAHLEN | H7

ES Acero, Acero Inoxidable, Fundición Gris, Cobre, Titanio, Aleaciones Resistentes al Calor y Aceros hasta 56 HRC.

EN Steel, Stainless Steel, Cast Iron, Cooper, Titanium, Heat Resistance Alloys and Hardened Steels up to 56 HRC.

FR Acier, Acier Inoxydable, Fonte Grise, Cuivre, Titane, Alliages de Résistance à la Chaleur et Acier Jusqu'à 56 HRC.

DE Stahl, Rostfreier Stahl, Gubeisen, Kupfer, Titan, Warmfeste Legierungen und Gehärteter Stahl 56 HRC.



HELIX 10° H7

Ref.	Dimensiones (mm)						Precio €
	D	d	L	Lc	U	Z	
RE100298	2,98	3	61	12	36	4	
RE100299	2,99	3	61	12	36	4	
RE100300	3,00	3	61	12	36	4	
RE100301	3,01	3	61	12	36	4	
RE100302	3,02	3	61	12	36	4	
RE100350	3,50	4	70	12	40	4	
RE100398	3,98	4	75	12	45	4	
RE100399	3,99	4	75	12	45	4	
RE100400	4,00	4	75	12	45	4	
RE100400L	4,00	4	105	16	80	4	
RE100401	4,01	4	75	12	45	4	
RE100402	4,02	4	75	12	45	4	
RE100450	4,50	5	80	12	52	4	
RE100498	4,98	5	86	16	56	4	
RE100499	4,99	5	86	16	56	4	
RE100500	5,00	5	86	16	56	4	
RE100500L	5,00	5	115	30	90	4	

ESCARIADOR DE METAL DURO Sin recubrimiento

H7



Ref.	Dimensiones (mm)						Precio €
	D	d	L	Lc	U	Z	
RE100501	5,01	5	86	16	56	4	
RE100502	5,02	5	86	16	56	4	
RE100510	5,10	5	86	16	56	4	
RE100520	5,20	6	86	16	56	4	
RE100530	5,30	6	86	16	56	4	
RE100550	5,50	6	86	16	56	4	
RE100598	5,98	6	86	16	56	4	
RE100599	5,99	6	86	16	56	4	
RE100600	6,00	6	86	16	56	4	
RE100600L	6,00	6	130	30	100	4	
RE100601	6,01	6	86	16	56	4	
RE100602	6,02	6	86	16	56	4	
RE100610	6,10	6	86	16	56	4	
RE100620	6,20	6	86	16	56	4	
RE100630	6,30	6	86	16	56	4	
RE100640	6,40	6	86	16	56	6	
RE100650	6,50	8	86	16	56	6	
RE100700	7,00	8	86	16	56	6	
RE100700L	7,00	8	140	30	110	6	
RE100750	7,50	8	86	16	56	6	
RE100798	7,98	8	86	16	56	6	
RE100799	7,99	8	86	16	56	6	
RE100800	8,00	8	86	16	56	6	
RE100800L	8,00	8	117	33	84	6	
RE100800LL	8,00	8	160	30	130	6	
RE100801	8,01	8	86	16	56	6	
RE100801L	8,01	8	117	33	84	6	
RE100802	8,02	8	86	16	56	6	
RE100802L	8,02	8	117	33	84	6	
RE100810L	8,10	8	117	33	84	6	
RE100820L	8,20	8	117	33	84	6	

ESCARIADOR DE METAL DURO Sin recubrimiento

H7



Ref.	Dimensiones (mm)						Precio €
	D	d	L	Lc	U	Z	
RE100830L	8,30	8	117	33	84	6	
RE100850	8,50	8	90	20	60	6	
RE100850L	8,50	8	117	33	84	6	
RE100898	8,98	10	90	20	60	6	
RE100899	8,99	10	90	20	60	6	
RE100900	9,00	10	90	20	60	6	
RE100900L	9,00	10	125	36	88	6	
RE100900LL	9,00	10	160	30	130	6	
RE100950	9,50	10	90	20	60	6	
RE100950L	9,50	10	125	36	88	6	
RE100998	9,98	10	90	20	60	6	
RE100999	9,99	10	90	20	60	6	
RE1001000	10,00	10	90	20	60	6	
RE1001000L	10,00	10	133	38	97	6	
RE1001000LL	10,00	10	190	30	150	6	
RE1001001	10,01	10	90	20	60	6	
RE1001001L	10,01	10	133	38	97	6	
RE1001002	10,02	10	90	20	60	6	
RE1001002L	10,02	10	133	38	97	6	
RE1001010L	10,10	10	133	38	97	6	
RE1001020L	10,20	10	133	38	97	6	
RE1001030L	10,30	10	133	38	97	6	
RE1001050	10,50	10	90	20	60	6	
RE1001050L	10,50	10	133	38	97	6	
RE1001100	11,00	12	90	20	60	6	
RE1001100L	11,00	12	151	44	110	6	
RE1001150	11,50	12	90	20	60	6	
RE1001150L	11,50	12	151	44	110	6	
RE1001198	11,98	12	90	20	60	6	
RE1001199	11,99	12	90	20	60	6	

ESCARIADOR DE METAL DURO Sin recubrimiento

H7



Ref.	Dimensiones (mm)						Precio €
	D	d	L	Lc	U	Z	
RE1001200	12,00	12	90	20	60	6	
RE1001200L	12,00	12	151	44	110	6	
RE1001200LL	12,00	12	220	35	170	6	
RE1001201	12,01	12	90	20	60	6	
RE1001201L	12,01	12	151	44	110	6	
RE1001202	12,02	12	90	20	60	6	
RE1001202L	12,02	12	151	44	110	6	
RE1001250L	12,50	12	151	44	110	6	
RE1001300	13,00	12	151	44	110	6	
RE1001300L	13,00	12	220	35	170	6	
RE1001301L	13,01	12	151	44	110	6	
RE1001302L	13,02	12	151	44	110	6	
RE1001400L	14,00	14	160	47	110	6	
RE1001400LL	14,00	14	220	35	170	6	
RE1001401L	14,01	14	160	47	110	6	
RE1001402L	14,02	14	160	47	110	6	
RE1001500L	15,00	14	162	50	112	6	
RE1001500LL	15,00	16	220	35	170	6	
RE1001501L	15,01	14	162	50	112	6	
RE1001502L	15,02	14	162	50	112	6	
RE1001600L	16,00	16	170	52	117	6	
RE1001600LL	16,00	16	230	40	180	6	
RE1001601L	16,01	16	170	52	117	6	
RE1001602L	16,02	16	170	52	117	6	
RE1001800L	18,00	18	182	56	129	6	
RE1001800LL	18,00	18	230	40	180	6	
RE1002000L	20,00	20	195	60	142	6	
RE1002000LL	20,00	20	230	40	180	6	



CONDICIONES DE CORTE

CUTTING PARAMETERS
PARAMÈTRES DE COUPE
SCHNITTDATEN

I H-SEM Z2

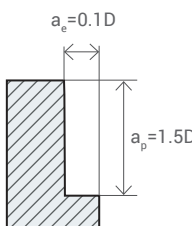
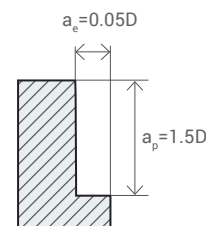
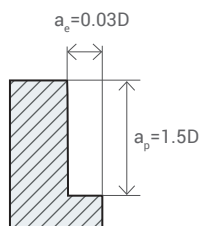
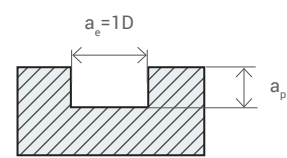
Workpiece material	Cast iron, Carbon steel, Alloy steel -30 HRC		Stainless steel		Pre-hardened steel, Quenched and tempered steel -40HRC		Pre-hardened steel, Quenched and tempered steel -50HRC		Hardened steel -56HRC																
	Diameter \varnothing (mm)	Rotating (min ⁻¹)	Feed (mm/min)	Rotating (min ⁻¹)	Feed (mm/min)	Rotating (min ⁻¹)	Feed (mm/min)	Rotating (min ⁻¹)	Feed (mm/min)	Rotating (min ⁻¹)	Feed (mm/min)														
1	20.000	200	20000	60	20000	165	20000	120	20000	90															
2	15.000	320	11150	85	15000	285	13000	180	11140	130															
3	14000	545	7500	120	10600	420	8500	330	7430	240															
4	10800	560	5500	135	8000	425	6500	335	5570	245															
5	8200	585	4500	135	6400	445	5000	355	4460	260															
6	7000	600	3700	140	5300	465	4200	360	3710	260															
8	5200	595	2800	140	4000	455	3200	365	2785	270															
10	4200	585	2200	140	3200	445	2500	350	2230	250															
12	3500	585	1850	140	2650	445	2100	350	1855	250															
14	3000	545	1600	135	2300	420	1800	330	1590	240															
16	2600	545	1400	120	2000	420	1600	330	1390	240															
18	2300	535	1250	120	1800	415	1400	325	1240	235															
20	2050	535	1100	120	1600	415	1250	325	1115	235															
25	1650	425	880	100	1300	345	1000	260	890	185															
Max. Cutting depth																									
				<table border="1"> <thead> <tr><th colspan="2">Milling Slot</th></tr> <tr><th>\varnothing</th><th>Ap</th></tr> </thead> <tbody> <tr><td>$\varnothing 1 \leq \varnothing 3$</td><td>0.15D</td></tr> <tr><td>$\varnothing 3 \leq \varnothing 6$</td><td>0.3D</td></tr> <tr><td>$\varnothing 6 \leq D < \varnothing 20$</td><td>0.5D</td></tr> </tbody> </table>			Milling Slot		\varnothing	Ap	$\varnothing 1 \leq \varnothing 3$	0.15D	$\varnothing 3 \leq \varnothing 6$	0.3D	$\varnothing 6 \leq D < \varnothing 20$	0.5D	<table border="1"> <thead> <tr><th colspan="2">Milling Slot</th></tr> <tr><th>\varnothing</th><th>Ap</th></tr> </thead> <tbody> <tr><td>$\varnothing 1 \leq D < \varnothing 3$</td><td>0.1D</td></tr> <tr><td>$\varnothing 3 \leq D$</td><td>0.2D</td></tr> </tbody> </table>		Milling Slot		\varnothing	Ap	$\varnothing 1 \leq D < \varnothing 3$	0.1D	$\varnothing 3 \leq D$
Milling Slot																									
\varnothing	Ap																								
$\varnothing 1 \leq \varnothing 3$	0.15D																								
$\varnothing 3 \leq \varnothing 6$	0.3D																								
$\varnothing 6 \leq D < \varnothing 20$	0.5D																								
Milling Slot																									
\varnothing	Ap																								
$\varnothing 1 \leq D < \varnothing 3$	0.1D																								
$\varnothing 3 \leq D$	0.2D																								

H-SEM Z4

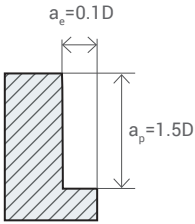
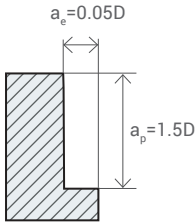
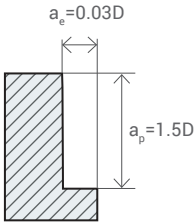
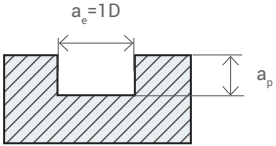
Workpiece material	Cast iron, Carbon steel, Alloy steel -30 HRC		Stainless steel		Pre-hardened steel, Quenched and tempered steel -40HRC		Pre-hardened steel, Quenched and tempered steel -50HRC		Hardened steel -56HRC																	
	Diameter \varnothing (mm)	Rotating (min ⁻¹)	Feed (mm/min)	Rotating (min ⁻¹)	Feed (mm/min)	Rotating (min ⁻¹)	Feed (mm/min)	Rotating (min ⁻¹)	Feed (mm/min)	Rotating (min ⁻¹)	Feed (mm/min)															
1	20.000	270	20000	95	20000	215	20000	135	20000	120																
2	15.000	435	11150	110	15000	380	13000	200	11140	175																
3	14000	735	7500	135	10600	565	8500	370	7430	325																
4	10800	755	5500	140	8000	575	6500	380	5570	335																
5	8200	795	4500	140	6400	605	5000	400	4460	350																
6	7000	810	3700	145	5300	620	4200	405	3710	350																
8	5200	800	2800	145	4000	615	3200	415	2785	365																
10	4200	795	2200	145	3200	605	2500	390	2230	340																
12	3500	795	1850	145	2650	605	2100	390	1855	340																
14	3000	735	1600	140	2300	565	1800	370	1590	325																
16	2600	735	1400	135	2000	565	1600	370	1390	325																
18	2300	720	1250	115	1800	555	1400	365	1240	315																
20	2050	720	1100	115	1600	555	1250	365	1115	2050																
25	1650	575	880	95	1300	445	1000	295	900	255																
Max. Cutting depth																										
				<table border="1"> <thead> <tr><th colspan="2">Milling Slot</th></tr> <tr><th>\varnothing</th><th>Ap</th></tr> </thead> <tbody> <tr><td>$\varnothing 1 \leq \varnothing 3$</td><td>0.15D</td></tr> <tr><td>$\varnothing 3 \leq \varnothing 6$</td><td>0.3D</td></tr> <tr><td>$\varnothing 6 \leq D < \varnothing 20$</td><td>0.5D</td></tr> </tbody> </table>			Milling Slot		\varnothing	Ap	$\varnothing 1 \leq \varnothing 3$	0.15D	$\varnothing 3 \leq \varnothing 6$	0.3D	$\varnothing 6 \leq D < \varnothing 20$	0.5D	<table border="1"> <thead> <tr><th colspan="2">Milling Slot</th></tr> <tr><th>\varnothing</th><th>Ap</th></tr> </thead> <tbody> <tr><td>$\varnothing 1 \leq D < \varnothing 3$</td><td>0.1D</td></tr> <tr><td>$\varnothing 3 \leq D$</td><td>0.2D</td></tr> </tbody> </table>			Milling Slot		\varnothing	Ap	$\varnothing 1 \leq D < \varnothing 3$	0.1D	$\varnothing 3 \leq D$
Milling Slot																										
\varnothing	Ap																									
$\varnothing 1 \leq \varnothing 3$	0.15D																									
$\varnothing 3 \leq \varnothing 6$	0.3D																									
$\varnothing 6 \leq D < \varnothing 20$	0.5D																									
Milling Slot																										
\varnothing	Ap																									
$\varnothing 1 \leq D < \varnothing 3$	0.1D																									
$\varnothing 3 \leq D$	0.2D																									

I H-SEM Z3

Workpiece material	Cast iron, Nodular cast iron		Carbon steel, Alloy steel -750Nmm ²		Carbon steel, Alloy steel -30HRC		Pre-hardened steel, Quenched and tempered steel -40HRC		Stainless steel		Pre-Hardened steel, Quenched and tempered steel -56HRC					
	Diameter Ø (mm)	Rotating (min ⁻¹)	Feed (mm/min)	Rotating (min ⁻¹)	Feed (mm/min)	Rotating (min ⁻¹)	Feed (mm/min)	Rotating (min ⁻¹)	Feed (mm/min)	Rotating (min ⁻¹)	Feed (mm/min)	Rotating (min ⁻¹)	Feed (mm/min)			
1	20.000	215	20000	215	20000	175	20000	175	20000	65	20000	130				
2	15.000	345	15000	345	15000	310	15000	305	11150	90	13000	195				
3	14000	590	14000	590	13000	546	10600	455	7500	130	8500	360				
4	10800	600	10800	605	10000	560	8000	460	5500	145	6500	365				
5	8200	630	8200	630	7600	585	6400	480	4500	145	5000	380				
6	7000	650	7000	650	6400	600	5300	500	3700	150	4200	390				
8	5200	645	5200	645	4800	590	4000	495	2800	150	3200	400				
10	4200	630	4200	630	3800	585	3200	480	2200	150	2500	380				
12	3500	630	3500	630	3200	585	2650	480	1850	150	2100	380				
14	3000	590	3000	590	2700	545	2300	455	1600	145	1800	360				
16	2600	590	2600	590	2400	545	2000	455	1400	130	1600	360				
18	2300	580	2300	580	2100	530	1800	450	1250	130	1400	350				
20	2050	580	2050	580	1900	530	1600	450	1100	130	1250	350				
25	1650	465	1650	465	1520	425	1300	370	880	110	1000	280				
Max. Cutting depth																
						<p style="text-align: center;">Milling Slot</p> <table border="1"> <thead> <tr> <th>Ø</th> <th>Ap</th> </tr> </thead> <tbody> <tr> <td>Ø1 ≤ D < Ø3</td> <td>0.15D</td> </tr> <tr> <td>Ø3 ≤ D</td> <td>0.3D</td> </tr> </tbody> </table>					Ø	Ap	Ø1 ≤ D < Ø3	0.15D	Ø3 ≤ D	0.3D
Ø	Ap															
Ø1 ≤ D < Ø3	0.15D															
Ø3 ≤ D	0.3D															

H-HEM Z6

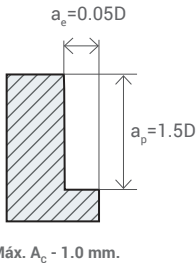
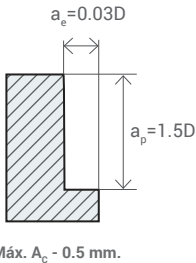
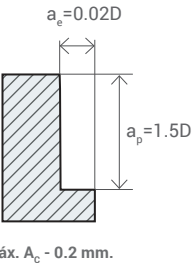
Workpiece material	Pre-hardened steel, Hardened steel 40-50HRC		Hardened steel 50-60HRC		Hardened steel 60-65HRC	
Cutting Speed	300m/min		150m/min		100m/min	
Diameter Ø (mm)	Rotating (min ⁻¹)	Feed (mm/min)	Rotating (min ⁻¹)	Feed (mm/min)	Rotating (min ⁻¹)	Feed (mm/min)
3	29.135	3380	14625	1690	9685	1130
4	22.940	2660	11515	1330	7625	890
5	18880	2180	9440	1090	6250	732
6	16000	1850	8000	925	5300	610
8	12000	1850	6000	925	4000	610
10	9600	1850	4800	925	3200	610
12	8000	1920	4000	960	2700	650
14	6800	1600	3400	815	2300	550
16	6000	1440	3000	720	2000	480
18	5300	1270	2700	635	1800	430
20	4800	1150	2400	575	1600	385
25	4250	1025	2120	510	1420	340
Max. Cutting depth						

FRESAS Z1 ALUMINIO

Workpiece material	Aleaciones de Aluminio, <6% Si		Aleaciones de Aluminio, <6-12% Si	
Cutting Speed	300m/min		150m/min	
Diameter Ø (mm)	Rotating (min ⁻¹)	Feed (mm/min)	Rotating (min ⁻¹)	Feed (mm/min)
3	32.000	480	21000	200
4	24.000	600	16000	290
5	19100	580	12700	300
6	16000	560	10600	300
8	12000	540	8000	280
10	9500	525	6400	255
12	8000	560	5300	265

Profundidad de corte: e: 1xD Ap.: 0,5xD

I A-SEM Z2

Workpiece material	Aluminum alloy		Silicon aluminium alloy Si≤10%	
Diameter Ø (mm)	Rotating (min ⁻¹)	Feed (mm/min)	Rotating (min ⁻¹)	Feed (mm/min)
3	26500	1500	21000	1100
4	20000	1600	16000	1250
5	16000	1500	13000	1100
6	13000	1250	10600	1000
8	10000	1400	8000	1100
10	8000	1600	6500	1250
12	6600	1650	5300	1300
14	5700	1700	4600	1350
16	5000	1700	4000	1350
20	4000	1700	3200	1350
Max. Cutting depth				

A-SEM Z3 / A-SEM Z3-R

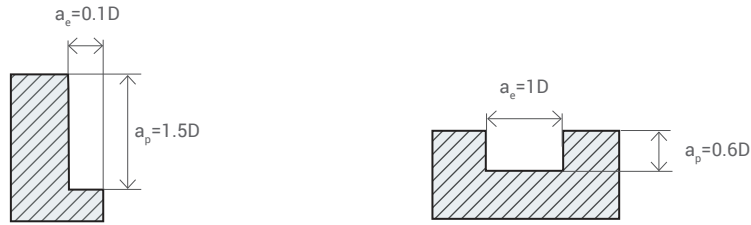
Workpiece material	Aluminum alloy		Silicon aluminium alloy Si≤10%		
	Diameter Ø (mm)	Rotating (min ⁻¹)	Feed (mm/min)	Rotating (min ⁻¹)	Feed (mm/min)
3		26500	1800	21000	1300
4		20000	2000	16000	1500
5		16000	1750	13000	1300
6		13000	1500	10600	1200
8		10000	1650	8000	1300
10		8000	1900	6500	1500
12		6600	1950	5300	1550
14		5700	2000	4600	1600
16		5000	2000	4000	1600
20		4000	2000	3200	1600
Max. Cutting depth					

A-SBM Z2

Workpiece material	Aluminum alloy		Silicon aluminium alloy Si≤10%		
	Diameter Ø (mm)	Rotating (min ⁻¹)	Feed (mm/min)	Rotating (min ⁻¹)	Feed (mm/min)
3		26500	1950	21000	1550
4		20000	1950	16000	1550
5		16000	1950	13000	1550
6		13000	2000	10600	1600
8		10000	2450	8000	2000
10		8000	2200	6500	1750
12		6600	2050	5300	1650
14		5700	2000	4600	1600
16		5000	1950	4000	1550
20		4000	1900	3200	1520

Max. Cutting depth

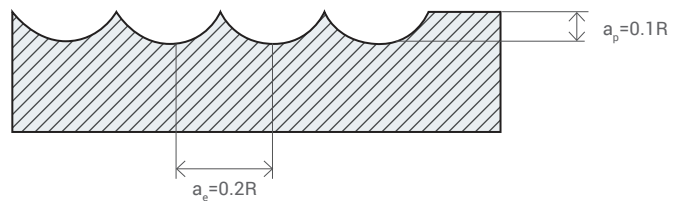

H-HEM Z6 LARGA

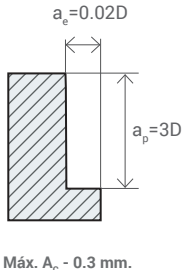
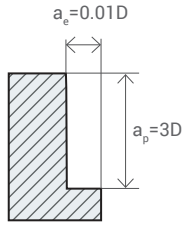
Workpiece material	Pre-hardened steel, Hardened steel 40-50HRC		Hardened steel 50-60HRC		Hardened steel 60-65HRC	
Cutting Speed	300m/min		150m/min		100m/min	
Diameter Ø (mm)	Rotating (min ⁻¹)	Feed (mm/min)	Rotating (min ⁻¹)	Feed (mm/min)	Rotating (min ⁻¹)	Feed (mm/min)
3	29.135	2380	14625	1190	9685	795
4	22.940	1875	11515	935	7625	626
5	18880	1535	9440	770	6250	515
6	16000	1300	8000	650	5300	430
8	12000	1300	6000	650	4000	430
10	9600	1300	4800	650	3200	430
12	8000	1350	4000	670	2700	460
14	6800	1150	3400	570	2300	380
16	6000	1000	3000	500	2000	340
18	5300	890	2700	450	1800	300
20	4800	800	2400	400	1600	270
25	4250	720	2120	360	1420	240
32	3900	680	2000	320	1350	190
Max. Cutting depth	 <p>Máx. A_c - 0.3 mm.</p>					

BW-SEM

Workpiece material	Cast Iron, Nodular cast iron		Carbon steel, Alloy steel -750Nmm ²		Carbon steel, Alloy steel -30 HRC		Pre-hardened steel, Quenched and tempered steel 40-50HRC		Stainless steel		
	Diameter Ø (mm)	Rotating (min ⁻¹)	Feed (mm/min)	Rotating (min ⁻¹)	Feed (mm/min)	Rotating (min ⁻¹)	Feed (mm/min)	Rotating (min ⁻¹)	Feed (mm/min)	Rotating (min ⁻¹)	Feed (mm/min)
6	6350	760	5300	640	4500	360	3450	280	2650	210	
8	4750	760	4000	640	3400	410	2650	310	2000	240	
10	3800	760	3200	640	2400	430	2050	330	1600	260	
12	3200	770	2250	650	1950	470	1500	360	1150	280	
14	2800	770	2125	650	1825	470	1400	360	1075	280	
16	2400	770	2000	640	1700	480	1300	360	1000	280	
20	1900	760	1600	610	1350	470	1050	350	800	260	
Max. Cutting depth											

M-SEM Ø4

Workpiece material	Pre-hardened steel, Hardened steel -40HRC		Hardened steel 40-56HRC		
	Diameter Ø (mm)	Rotating (min ⁻¹)	Feed (mm/min)	Rotating (min ⁻¹)	Feed (mm/min)
0.2	32.000	150	25000	120	
0.3	32.000	150	25000	120	
0.4	32000	200	25000	160	
0.5	21000	400	17000	300	
0.6	21000	480	17000	380	
0.7	20000	520	14000	360	
0.8	20000	560	14000	400	
0.9	17000	560	12000	400	
Max. Cutting depth					

■ H-SEM Ø6

Workpiece material		Pre-hardened steel, Hardened steel -40HRC			Hardened steel 40-56HRC		
Diameter Ø (mm)	Effective length(mm)	Rotating (min ⁻¹)	Feed (mm/min)	Ap (mm)	Feed (mm/min)	Rotating (min ⁻¹)	Ap (mm)
1.0	5	17000	400	0.03	12000	100	0.014
	12	12000	150	0.01	10000	50	0.008
1.5	5	12000	400	0.06	8000	200	0.028
	12	10000	300	0.025	7000	100	0.01
2.0	10	7000	300	0.10	6000	200	0.05
	16	7000	200	0.02	6000	100	0.008
3.0	10	7000	400	0.12	5000	300	0.06
	16	6000	300	0.06	5000	200	0.03
4.0	12	4500	400	0.16	4000	300	0.08
	20	4500	300	0.10	4000	300	0.04

Max. Cutting depth

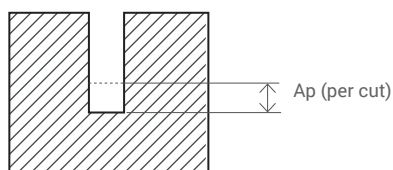

H-MEM

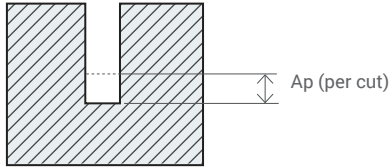
Workpiece material		Pre-hardened steel, Hardened steel 40-50HRC		Hardened steel 50-62HRC	
Diameter \varnothing (mm)	Effective length(mm)	Rotating (min ⁻¹)	Feed (mm/min)	Feed (mm/min)	Rotating (min ⁻¹)
0.5	4	28000	150	25000	100
	6	22000	100	20000	75
0.6	4	28000	150	25000	100
	6	22000	100	20000	75
	8	22000	75	18000	75
0.8	6	26000	200	21000	150
	8	22000	125	18000	100
	10	22000	75	18000	75
1.2	6	22000	400	17000	300
	8	19000	300	14000	200
	10	19000	300	14000	200
Max. Cutting depth					

H-SBM

Workpiece material	Cast iron, Carbon steel, Alloy steel -30 HRC		Stainless steel		Pre-hardened steel, Quenched and tempered steel -40HRC		Pre-hardened steel, Quenched and tempered steel -50HRC		Hardened steel 56-62HRC	
	Diameter Ø (mm)	Rotating (min ⁻¹)	Feed (mm/min)	Rotating (min ⁻¹)	Feed (mm/min)	Rotating (min ⁻¹)	Feed (mm/min)	Rotating (min ⁻¹)	Feed (mm/min)	Rotating (min ⁻¹)
1.0	40000	960	22300	240	32000	385	25000	330	22280	295
1.5	32.000	1020	16500	255	24000	435	19000	330	16700	295
2.0	24000	1080	11150	275	16000	480	13000	330	11140	295
2.5	15500	1150	5550	445	8000	665	6500	450	5570	385
3.0	15500	1150	5550	445	8000	665	6500	450	5570	385
4.0	11500	1150	5550	445	8000	665	6500	450	5570	385
5.0	9500	1270	4450	445	6400	665	5000	455	4455	405
6.0	8000	1270	3700	470	5300	700	4200	470	3715	420
8.0	6000	1575	2750	550	4000	850	3200	535	2785	465
10	4800	1455	2200	520	3200	785	2500	535	2230	465
12	4000	1330	1850	520	2650	740	2100	505	1855	450
14	3500	1300	1550	500	2400	730	1800	475	1670	425
16	3000	1270	1350	455	2000	725	1600	455	1395	395
18	2700	1200	1250	455	1800	700	1400	425	1275	375
20	2400	1150	1100	445	1600	675	1250	400	1115	360

Max. Cutting depth

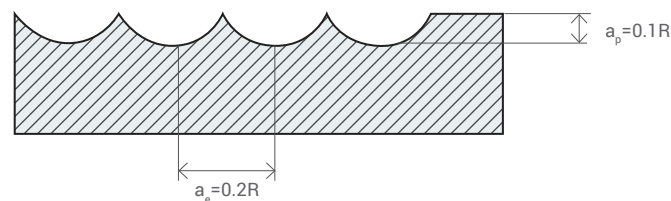

H-NBM

Workpiece material		Pre-hardened steel, Hardened steel 40-50HRC				Hardened steel 50-62HRC			
Diameter \varnothing (mm)	Effective length(mm)	Rotating (min ⁻¹)	Feed (mm/min)	Ap (mm)	Ae (mm)	Rotating (min ⁻¹)	Feed (mm/min)	Ap (mm)	Ae (mm)
1	5	16000	200	0.05	0.10	11500	150	0.05	0.10
	12	14000	135	0.01	0.03	9800	75	0.01	0.03
2	10	10000	275	0.08	0.16	5500	175	0.08	0.16
	14	10000	275	0.06	0.16	5500	175	0.06	0.16
	16	10000	250	0.02	0.10	5500	150	0.02	0.10
	35	8000	175	0.02	0.05	5500	125	0.01	0.05
2.5	20	5500	175	0.02	0.05	5000	125	0.01	0.05
3	9	7500	400	0.15	0.30	4000	200	0.15	0.30
	15	6500	250	0.05	0.20	3000	150	0.05	0.20
	20	6500	250	0.02	0.10	3000	150	0.02	0.05
	40	5000	200	0.02	0.1	2500	100	0.02	0.05
4	12	6000	400	0.20	0.40	3000	200	0.20	0.40
	20	5000	250	0.10	0.20	2500	100	0.10	0.20
5	20	4000	250	0.25	0.50	3000	100	0.20	0.2

Max. Cutting depth

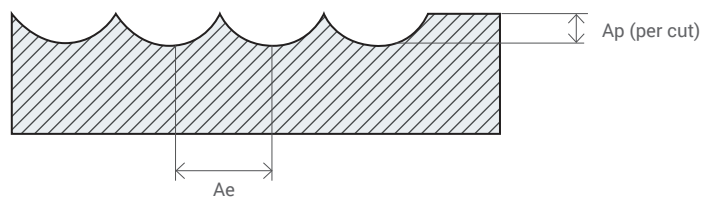

H-CBM

Workpiece material		Pre-hardened steel, Hardened steel 40-50HRC				Hardened steel 50-62HRC			
Diameter \varnothing (mm)	Effective length(mm)	Rotating (min ⁻¹)	Feed (mm/min)	Ap (mm)	Ae (mm)	Rotating (min ⁻¹)	Feed (mm/min)	Ap (mm)	Ae (mm)
1	20	22000	450	0.02	0.1	22000	345	0.02	0.1
1.5	20	20000	750	0.03	0.15	20000	700	0.03	0.15
2	20	18000	1000	0.05	0.2	18000	800	0.05	0.2
	40	18000	750	0.03	0.2	18000	600	0.05	0.2
3	30	16000	1200	0.1	0.3	16000	960	0.1	0.3
	50	16000	850	0.03	0.3	16000	680	0.03	0.3
4	30	14000	1400	0.15	0.4	14000	1120	0.15	0.4
	60	14000	1100	0.1	0.4	14000	880	0.1	0.4
5	60	11700	1400	0.25	0.5	11700	880	0.25	0.5

Max. Cutting depth

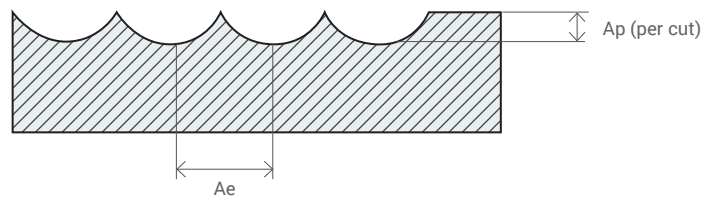

TORICA Z2

Workpiece material	Cast iron, Carbon steel, Alloy steel -30 HRC		Stainless steel		Pre-hardened steel, Quenched and tempered steel -40HRC		Pre-hardened steel, Quenched and tempered steel -50HRC		Hardened steel 56-62HRC						
	Diameter Ø (mm)	Rotating (min ⁻¹)	Feed (mm/min)	Rotating (min ⁻¹)	Feed (mm/min)	Rotating (min ⁻¹)	Feed (mm/min)	Rotating (min ⁻¹)	Feed (mm/min)	Rotating (min ⁻¹)	Feed (mm/min)				
1	20000	240	20000	75	20000	195	20000	145	20000	95					
1.5	17000	300	15500	90	17000	260	16000	180	15500	110					
2	15000	385	11150	100	15000	335	13000	215	11140	130					
3	14000	655	7500	145	10600	505	8500	395	7430	245					
4	10800	675	5500	155	8000	515	6500	405	5570	245					
5	8200	695	4500	155	6400	540	5000	425	4460	260					
6	7000	720	3700	170	5300	555	4200	435	3710	260					
8	5200	720	2800	170	4000	555	3200	440	2785	275					
10	4200	695	2200	170	3200	535	2500	420	2230	255					
12	3500	695	1850	170	2650	535	2100	420	1855	255					
Max. Cutting depth															

TORICA Z4

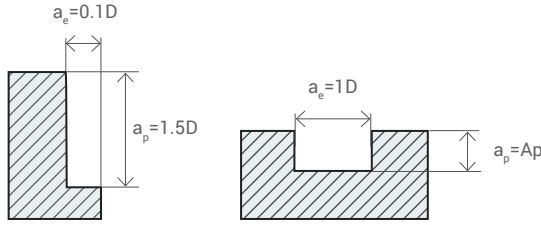
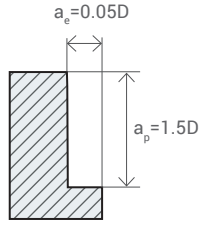
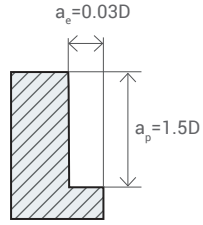
Workpiece material	Cast iron, Carbon steel, Alloy steel -30 HRC		Stainless steel		Pre-hardened steel, Quenched and tempered steel -40HRC		Pre-hardened steel, Quenched and tempered steel -50HRC		Hardened steel 56-62HRC						
	Diameter \varnothing (mm)	Rotating (min ⁻¹)	Feed (mm/min)	Rotating (min ⁻¹)	Feed (mm/min)	Rotating (min ⁻¹)	Feed (mm/min)	Rotating (min ⁻¹)	Feed (mm/min)	Rotating (min ⁻¹)	Feed (mm/min)				
2	15000	950	9500	175	15000	720	13000	550	9500	400					
3	14000	985	7500	175	10600	755	8500	590	7430	435					
4	10800	1010	5500	175	8000	770	6500	600	5570	445					
5	8200	1055	4500	175	6400	805	5000	640	4460	470					
6	7000	1080	3700	195	5300	830	4200	650	3710	470					
8	5200	1070	2800	195	4000	815	3200	660	2785	485					
10	4200	1055	2200	195	3200	805	2500	625	2230	450					
12	3500	1055	1850	195	2650	805	2100	625	1855	450					
Max. Cutting depth															

H-CEM Z2

Workpiece material	Cast iron, Carbon steel, Alloy steel -30 HRC		Stainless steel		Pre-hardened steel, Quenched and tempered steel -40HRC		Pre-hardened steel, Quenched and tempered steel -50HRC		Hardened steel 56-62HRC											
	Diameter Ø (mm)	Rotating (min ⁻¹)	Feed (mm/min)	Rotating (min ⁻¹)	Feed (mm/min)	Rotating (min ⁻¹)	Feed (mm/min)	Rotating (min ⁻¹)	Feed (mm/min)	Rotating (min ⁻¹)	Feed (mm/min)									
2	15000	385	11150	100	15000	335	13000	215	11140	130										
3	14000	655	7500	145	10600	505	8500	395	7430	245										
4	10800	675	5500	155	8000	515	6500	405	5570	245										
5	8200	695	4500	155	6400	540	5000	425	4460	260										
6	7000	720	3700	170	5300	555	4200	435	3710	260										
8	5200	720	2800	170	4000	555	3200	440	2785	275										
Max. Cutting depth																				

H-CEM Z4

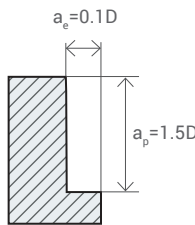
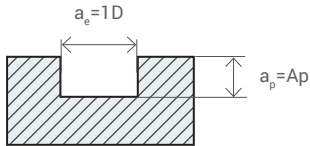
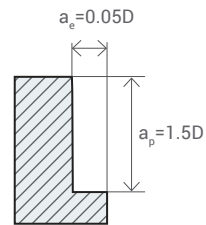
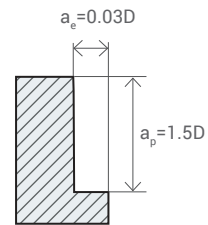
Workpiece material	Cast iron, Carbon steel, Alloy steel -30 HRC		Stainless steel		Pre-hardened steel, Quenched and tempered steel -40HRC		Pre-hardened steel, Quenched and tempered steel -50HRC		Hardened steel 56-62HRC											
	Diameter \varnothing (mm)	Rotating (min ⁻¹)	Feed (mm/min)	Rotating (min ⁻¹)	Feed (mm/min)	Rotating (min ⁻¹)	Feed (mm/min)	Rotating (min ⁻¹)	Feed (mm/min)	Rotating (min ⁻¹)	Feed (mm/min)									
2	15000	950	9500	175	15000	720	13000	550	9500	400										
3	14000	985	7500	175	10600	755	8500	590	7430	435										
4	10800	1010	5500	175	8000	770	6500	600	5570	445										
5	8200	1055	4500	175	6400	805	5000	640	4460	470										
6	7000	1080	3700	195	5300	830	4200	650	3710	470										
8	5200	1070	2800	195	4000	815	3200	660	2785	485										
Max. Cutting depth																				

HYRUX / HYPERLINK

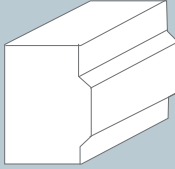
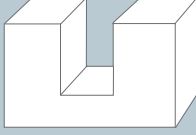
										
		Fresado lateral A y B, Ranurado C								
		A		B		C		Velocidad de corte v_c m/min		
		ap	ae	ap	ae	ap	min	max	mm	
P	1	2 x D	0,1-0,2 x D	1,5 x D	0,5 x D	1 x D	150	220	fz	
	2	2 x D	0,1-0,2 x D	1,5 x D	0,5 x D	1 x D	150	200	fz	
	3	2 x D	0,1-0,2 x D	1,5 x D	0,5 x D	1 x D	120	170	fz	
	4	2 x D	0,1-0,2 x D	1,5 x D	0,5 x D	1 x D	110	160	fz	
	5	2 x D	0,1-0,2 x D	1,5 x D	0,5 x D	1 x D	70	90	fz	
M	1	2 x D	0,1-0,2 x D	1,5 x D	0,5 x D	1 x D	90	115	fz	
	2	2 x D	0,1-0,2 x D	1,5 x D	0,5 x D	1 x D	80	100	fz	
	3	2 x D	0,1-0,2 x D	1,5 x D	0,5 x D	1 x D	95	125	fz	
K	1	2 x D	0,1-0,2 x D	1,5 x D	0,5 x D	1 x D	180	220	fz	
	2	2 x D	0,1-0,2 x D	1,5 x D	0,5 x D	1 x D	150	180	fz	
	3	2 x D	0,1-0,2 x D	1,5 x D	0,5 x D	1 x D	120	150	fz	
S	1	2 x D	0,1 x D	1,5 x D	0,5 x D	1 x D	60	100	fz	
	2	2 x D	0,1 x D	1,5 x D	0,5 x D	1 x D	50	80	fz	
	3	2 x D	0,1 x D	1,5 x D	0,3 x D	0,3 x D	30	50	fz	
	4	2 x D	0,1 x D	1,5 x D	0,3 x D	0,3 x D	25	40	fz	
H	1	2 x D	0,1 x D	1,5 x D	0,3 x D	0,75 x D	80	110	fz	

- P1** Non alloyed steel <700 N/mm²
P2 Low alloyed steel <24HRC 700-1000 N/mm²
P3 High alloyed steel <30HRC <700 N/mm²
P4 Hardened steel 30-38HRC
P5 Hardened steel 38-48HRC
M1 Stainless steel, austenitic 500-950 N/mm²
M2 Stainless steel, ferritic, martensitic 500-950 N/mm²
M3 Stainless steel, martensitic 800-1000 N/mm²
K1 Grey Cast Iron, 100-400 N/mm²
K2 Alloyed grey-Nodular cast Iron, 200-800 N/mm²
K3 Malleable cast iron, 350-700 N/mm²
S1 Titanium alloys, medium strength, <950N/mm²
S2 Titanium alloys, high strength, 900-1400N/mm²
S3 Nickel based Alloys, medium strength <950N/mm²
S4 Heat resistant Nickel based Alloys, high strength 900-1400 N/mm²
H1 Hardened steel 48-56HRC

Avance por diente recomendado (f_z =mm/diente) para fresado lateral (A) y (B). Para ranurado C, reduzca el valor f_z en un 20%.

D1 / Diametro

3,0	4,0	5,0	6,0	8,0	10,0	12,0	14,0	16,0	20,0
0,022	0,028	0,035	0,045	0,06	0,07	0,08	0,09	0,1	0,11
0,022	0,028	0,035	0,045	0,06	0,07	0,08	0,09	0,1	0,11
0,022	0,028	0,035	0,045	0,06	0,07	0,08	0,09	0,1	0,11
0.018	0.023	0.030	0.035	0.050	0.060	0.070	0.080	0.09	0.10
0.015	0.017	0.025	0.030	0.040	0.050	0.055	0.065	0.07	0.08
0.018	0.023	0.030	0.035	0.050	0.060	0.070	0.080	0.09	0.10
0,022	0,028	0,035	0,045	0,06	0,07	0,08	0,09	0,1	0,11
0.020	0.025	0.030	0.035	0.045	0.07	0.075	0.09	0.095	0.105
0,022	0,028	0,035	0,045	0,06	0,07	0,08	0,09	0,1	0,11
0.018	0.023	0.030	0.035	0.050	0.060	0.070	0.080	0.09	0.10
0.018	0.023	0.030	0.035	0.050	0.060	0.070	0.080	0.09	0.10
0,022	0,028	0,035	0,035	0,05	0,06	0,06	0,1	0,1	0,11
0.015	0.020	0.025	0.025	0.04	0.040	0.040	0.06	0.06	0.07
0,022	0,028	0,035	0,035	0,05	0,06	0,06	0,1	0,1	0,11
0.015	0.020	0.025	0.025	0.04	0.040	0.040	0.06	0.06	0.07
0.018	0.023	0.030	0.035	0.050	0.060	0.070	0.080	0.09	0.10

T-SEM (TURBO)

Workpiece material	Cast iron, Carbon steel, Alloy steel -30 HRC		Pre-hardened steel, Quenched and tempered steel -40HRC		Pre-hardened steel, Quenched and tempered steel -45HRC		Pre-hardened steel, Quenched and tempered steel -50HRC		Hardened steel 55-62HRC	
	Diameter Ø (mm)	Rotating (min ⁻¹)	Feed (mm/min)	Rotating (min ⁻¹)	Feed (mm/min)	Rotating (min ⁻¹)	Feed (mm/min)	Rotating (min ⁻¹)	Feed (mm/min)	Rotating (min ⁻¹)
3	10500	6250	8500	4500	7450	3900	5300	2600	3200	995
4	7.950	6600	6350	4800	5550	4200	4000	2750	2400	1050
6	5300	7000	4250	5100	3700	4450	2650	2850	1600	1150
8	4550	7000	3200	5100	2800	4450	2000	2850	1200	1150
10	3200	7000	2550	5100	2250	4450	1600	2850	955	1150
12	2650	7000	2100	5100	1850	4450	1350	2850	795	1150
	max Ap: 0.5mm Ae: 0.5D Ap: 0.2R		max Ap: 0.5mm Ae: 0.5D Ap: 0.2R		max Ap: 0.5mm Ae: 0.5D Ap: 0.2R		max Ap: 0.4mm Ae: 0.5D Ap: 0.2R		max Ap: 0.2mm Ae: 0.5D Ap: 0.2R	

FRESA ACHAFLANAR

Workpiece material	Cast iron, Carbon steel, Alloy steel -30 HRC		Stainless Steel		Pre-hardened steel, Quenched and tempered steel 40-55HRC		Non ferrite materials	
	Diameter Ø (mm)	Vc (m/min)	fz (mm/z)	Vc (m/min)	fz (mm/z)	Vc (m/min)	fz (mm/z)	Vc (m/min)
4	90	0.02	60-90	0.02	70-120	0.02	200-280	0.02
6	90	0.03	60-90	0.03	70-120	0.03	200-280	0.03
8	90	0.04	60-90	0.04	70-120	0.04	200-280	0.04
10	90	0.05	60-90	0.05	70-120	0.05	200-280	0.05
12	90	0.06	60-90	0.06	70-120	0.06	200-280	0.06
16	90	0.08	60-90	0.08	70-120	0.08	200-280	0.08

FRESA TROCOIDAL - 3XD

Workpiece material	Cast iron, Carbon steel, Alloy steel -30 HRC		Stainless Steel		Pre-hardened steel, Quenched and tempered steel 30-40HRC		Pre-hardened steel, Quenched and tempered steel 45-55HRC	
	Vc (m/min)	fz (mm/z)	Vc (m/min)	fz (mm/z)	Vc (m/min)	fz (mm/z)	Vc (m/min)	fz (mm/z)
6	250-350	0.065	150-220	0.055	150-230	0.055	55-75	0.050
8	250-350	0.075	150-220	0.065	150-230	0.065	55-75	0.060
10	250-350	0.100	150-220	0.080	150-230	0.080	55-75	0.070
12	250-350	0.120	150-220	0.100	150-230	0.100	55-75	0.090
16	250-350	0.150	150-220	0.130	150-230	0.130	55-75	0.110
20	250-350	0.200	150-220	0.170	150-230	0.170	55-75	0.130

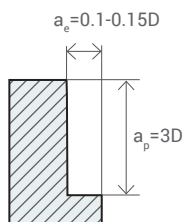

BROCA 3D / 5D

Workpiece material	Mild steel HB≤180		Carbon steel, alloy steel -30HRC		Pre-hardened steel 40-50HRC		Stainless steel		Cash iron		Nodular Cash iron GGG		Aluminum alloy		Heat resistant alloy	
	Vc															
∅ (mm)	n (min ⁻¹)	f (mm/r)	n (min ⁻¹)	f (mm/r)	n (min ⁻¹)	f (mm/r)	n (min ⁻¹)	f (mm/r)	n (min ⁻¹)	f (mm/r)	n (min ⁻¹)	f (mm/r)	n (min ⁻¹)	f (mm/r)	n (min ⁻¹)	f (mm/r)
3	9500	0.09-0.12	9500	0.09-0.12	6300	0.09-0.12	3700	0.03-0.07	9500	0.09-0.12	7400	0.09-0.12	10600	0.09-0.12	2100	0.03-0.06
4	7000	0.10-0.15	7000	0.10-0.15	4700	0.10-0.15	2700	0.04-0.08	7000	0.10-0.15	5600	0.10-0.15	8000	0.10-0.15	1600	0.04-0.07
5	5700	0.12-0.18	5700	0.12-0.18	3800	0.12-0.18	2200	0.05-0.10	5700	0.12-0.18	4500	0.12-0.18	6400	0.12-0.18	1250	0.05-0.09
6	4700	0.14-0.20	4700	0.14-0.20	3100	0.14-0.20	1850	0.06-0.12	4700	0.14-0.20	3700	0.14-0.20	5300	0.14-0.20	1050	0.06-0.11
8	3600	0.16-0.24	3600	0.16-0.24	2400	0.16-0.24	1400	0.08-0.16	3600	0.16-0.24	2800	0.16-0.24	4000	0.16-0.24	800	0.08-0.14
10	2800	0.18-0.27	2800	0.18-0.27	1900	0.18-0.27	1100	0.10-0.18	2800	0.18-0.27	2200	0.16-0.27	3200	0.18-0.27	600	0.10-0.16
12	2400	0.20-0.30	2400	0.20-0.30	1600	0.20-0.30	930	0.12-0.20	2400	0.20-0.30	1900	0.20-0.30	2700	0.20-0.30	500	0.12-0.18
14	2100	0.22-0.35	2100	0.22-0.35	1400	0.22-0.35	800	0.13-0.22	2100	0.22-0.35	1600	0.22-0.35	2300	0.22-0.35	450	0.13-0.20
16	1800	0.25-0.36	1800	0.25-0.36	1200	0.25-0.36	700	0.14-0.25	1800	0.25-0.36	1400	0.25-0.36	2000	0.25-0.36	400	0.14-0.25
18	1600	0.28-0.38	1600	0.28-0.38	1100	0.28-0.38	620	0.15-0.28	1600	0.28-0.38	1200	0.28-0.38	1800	0.28-0.38	350	0.15-0.25
20	1400	0.30-0.40	1400	0.30-0.40	950	0.30-0.40	550	0.16-0.30	1400	0.30-0.40	1100	0.30-0.40	1600	0.30-0.40	320	0.16-0.20

BROCA 5D REFRIGERADA

Work-piece material	Mild steel HB≤180		Carbon steel, alloy steel -30HRC		Pre-hardened steel 40-50HRC		Stainless steel		Cash iron		Nodular Cash iron GGG		Aluminum alloy		Heat resistant alloy	
	80-150m/min		80-150m/min		50-80 m/min		50-80 m/min		80-150 m/min		60-120 m/min		100-120 m/min		12-25 m/min	
∅ (mm)	n (min ⁻¹)	f (mm/r)	n (min ⁻¹)	f (mm/r)	n (min ⁻¹)	f (mm/r)	n (min ⁻¹)	f (mm/r)	n (min ⁻¹)	f (mm/r)	n (min ⁻¹)	f (mm/r)	n (min ⁻¹)	f (mm/r)	n (min ⁻¹)	f (mm/r)
3	12700	0.09-0.12	12700	0.09-0.12	7400	0.09-0.12	6300	0.03-0.07	12700	0.09-0.12	9500	0.09-0.12	15000	0.09-0.12	2100	0.03-0.06
4	9600	0.10-0.15	9600	0.10-0.15	5600	0.10-0.15	4700	0.04-0.08	9600	0.10-0.15	7000	0.10-0.15	11100	0.10-0.15	1600	0.04-0.07
5	7600	0.12-0.18	7600	0.12-0.18	4500	0.12-0.18	3800	0.05-0.10	7600	0.12-0.18	5700	0.12-0.18	9000	0.12-0.18	1250	0.05-0.09
6	6400	0.14-0.20	6400	0.14-0.20	3700	0.14-0.20	3200	0.06-0.12	6400	0.14-0.20	4700	0.14-0.20	7400	0.14-0.20	1050	0.06-0.11
8	4800	0.16-0.24	4800	0.16-0.24	2800	0.16-0.24	2400	0.08-0.16	4800	0.16-0.24	3600	0.16-0.24	5600	0.16-0.24	800	0.08-0.14
10	3800	0.18-0.27	3800	0.18-0.27	2200	0.18-0.27	1900	0.10-0.18	3800	0.18-0.27	2800	0.16-0.27	4500	0.18-0.27	600	0.10-0.16
12	3200	0.20-0.30	3200	0.20-0.30	1900	0.20-0.30	1600	0.12-0.20	3200	0.20-0.30	2400	0.20-0.30	3700	0.20-0.30	500	0.12-0.18
14	2700	0.22-0.35	2700	0.22-0.35	1600	0.22-0.35	1350	0.13-0.22	2700	0.22-0.35	2100	0.22-0.35	3200	0.22-0.35	450	0.13-0.20
16	2400	0.25-0.36	2400	0.25-0.36	1400	0.25-0.36	1200	0.14-0.25	2400	0.25-0.36	1800	0.25-0.36	2800	0.25-0.36	400	0.14-0.25
18	2100	0.28-0.38	2100	0.28-0.38	1200	0.28-0.38	1050	0.15-0.28	2100	0.28-0.38	1600	0.28-0.38	2500	0.28-0.38	350	0.15-0.25
20	1900	0.30-0.40	1900	0.30-0.40	1100	0.30-0.40	950	0.16-0.30	1900	0.30-0.40	1400	0.30-0.40	2300	0.30-0.40	320	0.16-0.20

BROCA 8D REFRIGERADA

Work-piece material	Mild steel HB≤180		Carbon steel, alloy steel -30HRC		Pre-hardened steel 40-50HRC		Stainless steel		Cash iron		Nodular Cash iron GGG		Aluminum alloy		Heat resistant alloy		
	Vc		80-150m/min		80-150m/min		50-80 m/min		40-60 m/min		80-150 m/min		60-120 m/min		100-180 m/min		15-25 m/min
∅ (mm)	n (min ⁻¹)	f (mm/r)	n (min ⁻¹)	f (mm/r)	n (min ⁻¹)	f (mm/r)	n (min ⁻¹)	f (mm/r)	n (min ⁻¹)	f (mm/r)	n (min ⁻¹)	f (mm/r)	n (min ⁻¹)	f (mm/r)	n (min ⁻¹)	f (mm/r)	
3	12700	0.06-0.10	12700	0.06-0.10	7400	0.06-0.10	5300	0.03-0.07	12700	0.06-0.10	9500	0.06-0.10	15000	0.09-0.12	2100	0.03-0.06	
4	9600	0.08-0.12	9600	0.08-0.12	5600	0.08-0.12	4000	0.04-0.08	9600	0.08-0.12	7000	0.08-0.12	11100	0.10-0.15	1600	0.04-0.07	
5	7600	0.10-0.14	7600	0.10-0.14	4500	0.10-0.14	3200	0.05-0.10	7600	0.10-0.14	5700	0.10-0.14	9000	0.10-0.14	1250	0.05-0.09	
6	6400	0.11-0.16	6400	0.11-0.16	3700	0.11-0.16	2700	0.06-0.12	6400	0.11-0.16	4700	0.11-0.16	7400	0.11-0.16	1050	0.06-0.11	
8	4800	0.13-0.19	4800	0.13-0.19	2800	0.13-0.19	2000	0.08-0.16	4800	0.13-0.19	3600	0.13-0.19	5600	0.13-0.19	800	0.08-0.14	
10	3800	0.14-0.22	3800	0.14-0.22	2200	0.14-0.22	1600	0.10-0.18	3800	0.14-0.22	2800	0.14-0.22	4500	0.14-0.22	600	0.10-0.16	
12	3200	0.16-0.24	3200	0.16-0.24	1900	0.16-0.24	1300	0.12-0.20	3200	0.16-0.24	2400	0.16-0.24	3700	0.16-0.24	500	0.12-0.18	
14	2700	0.18-0.28	2700	0.18-0.28	1600	0.18-0.28	1100	0.13-0.22	2700	0.18-0.28	2100	0.18-0.28	3200	0.18-0.28	450	0.13-0.20	
16	2400	0.20-0.29	2400	0.20-0.29	1400	0.20-0.29	1000	0.14-0.25	2400	0.20-0.29	1800	0.20-0.29	2800	0.20-0.29	400	0.14-0.23	
18	2100	0.24-0.32	2100	0.24-0.32	1200	0.24-0.32	880	0.15-0.28	2100	0.24-0.32	1600	0.24-0.32	2500	0.24-0.32	350	0.15-0.25	

ESCARIADOR

Workpiece material	Steel <1000 N/mm ² , Cast Iron, Modular cast iron			Copper alloy			Aluminium alloy		
V _c	8-16 m/min			10-25 m/min			15-30 m/min		
Ø (mm)	n (min ⁻¹)	f (mm/r)	Tolerance (mm)	n (min ⁻¹)	f (mm/r)	Tolerance (mm)	n (min ⁻¹)	f (mm/r)	Tolerance (mm)
3	1150	0.03-0.05	0.1-0.2	1900	0.03-0.05	0.1-0.2	2400	0.03-0.05	0.1-0.2
4	950	0.04-0.06	0.1-0.2	1600	0.04-0.06	0.1-0.2	2000	0.04-0.06	0.1-0.2
5	760	0.05-0.09	0.1-0.2	1300	0.05-0.09	0.1-0.2	1600	0.05-0.09	0.1-0.2
6	640	0.06-0.12	0.1-0.2	1050	0.06-0.12	0.1-0.2	1300	0.06-0.12	0.1-0.2
7	550	0.07-0.14	0.1-0.2	910	0.07-0.14	0.1-0.2	1150	0.07-0.14	0.1-0.2
8	480	0.08-0.16	0.1-0.2	800	0.08-0.16	0.1-0.2	1000	0.08-0.16	0.1-0.2
9	430	0.09-0.18	0.1-0.2	710	0.09-0.18	0.1-0.2	890	0.09-0.18	0.1-0.2
10	380	0.10-0.20	0.1-0.2	640	0.10-0.20	0.1-0.2	800	0.10-0.20	0.1-0.2
11	350	0.11-0.22	0.1-0.2	580	0.11-0.22	0.1-0.2	720	0.11-0.22	0.1-0.2
12	320	0.12-0.24	0.1-0.2	530	0.12-0.24	0.1-0.2	660	0.12-0.24	0.1-0.2
13	290	0.13-0.26	0.1-0.2	490	0.13-0.26	0.1-0.2	610	0.13-0.26	0.1-0.2
14	270	0.14-0.28	0.1-0.2	460	0.14-0.28	0.1-0.2	570	0.14-0.28	0.1-0.2
15	250	0.15-0.30	0.1-0.2	430	0.15-0.30	0.1-0.2	530	0.15-0.30	0.1-0.2
16	240	0.16-0.32	0.1-0.2	400	0.16-0.32	0.1-0.2	500	0.16-0.32	0.1-0.2
17	225	0.18-0.34	0.1-0.2	380	0.18-0.34	0.1-0.2	470	0.18-0.34	0.1-0.2
18	210	0.20-0.36	0.1-0.2	350	0.20-0.36	0.1-0.2	440	0.20-0.36	0.1-0.2
19	200	0.22-0.34	0.1-0.2	340	0.22-0.34	0.1-0.2	420	0.22-0.34	0.1-0.2
20	190	0.24-0.40	0.1-0.2	320	0.24-0.40	0.1-0.2	400	0.24-0.40	0.1-0.2



CATÁLOGO de productos

PRODUCT CATALOGUE
CATALOGUE DES PRODUITS
PRODUKTKATALOG



Meatz Erreka 11 bajo
ARRASATE-MONDRAGÓN
20500 (GIPUZKOA) SPAIN
Tel.: +34 943 79 10 22
Mail: info@arralbe.com

www.arralbe.com